

HP40BEE, HP50BEE, HP65BEE1

HEAT PUMP REPLACEMENT PARTS

Parts Listing: HP40BEE, HP50BEE, HP65BEE1

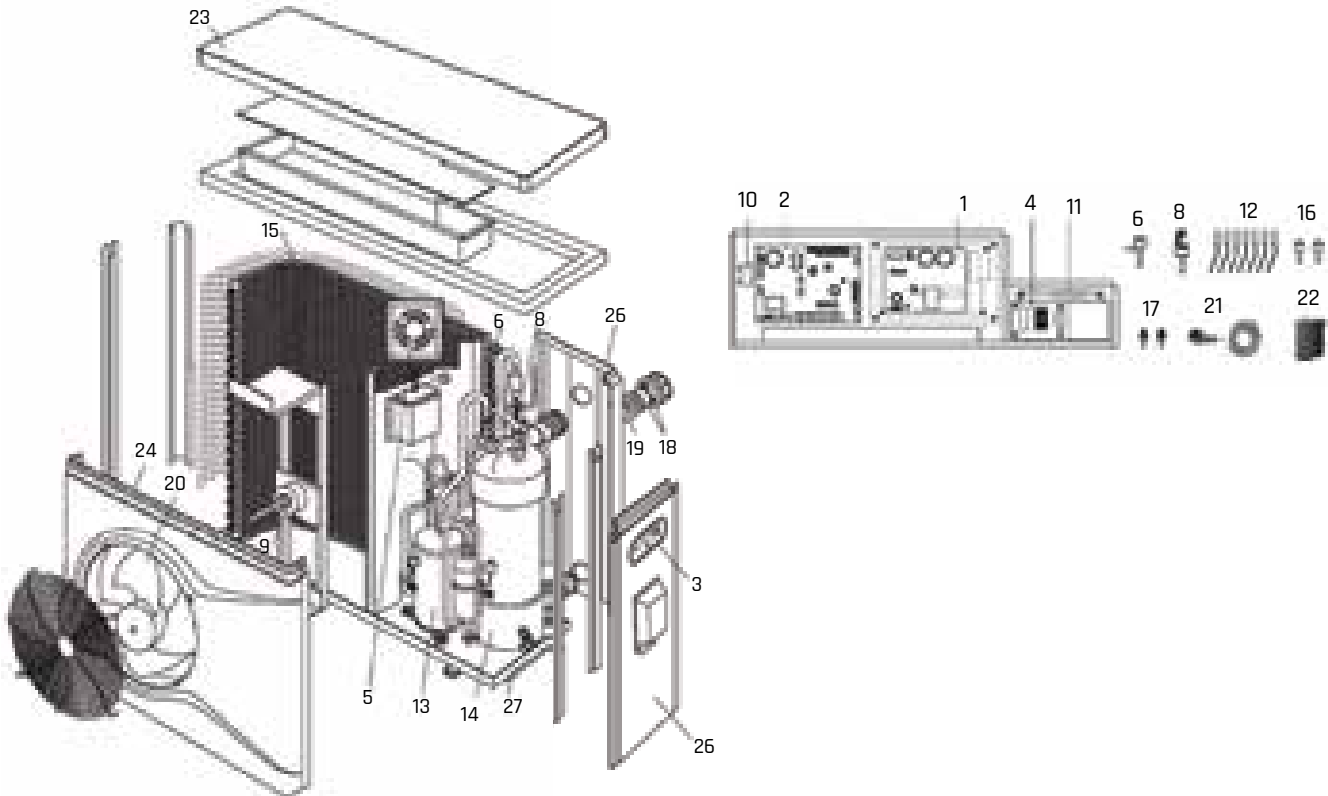

HP40BEE

Ref. No.	Part No.	Description
1	HPXWSEE40CDM	Inverter Board
2	HPXWSEE50PCB	PC Board
3	HPXWSEE50IL	Oval LED
4	HPXWSEE50PPF	Power Filter Plate
5	HPXWSEE40IN	Inductor
6	HPXWSEE50EV	Electronic Expansion Valve
7	HPXWSEE50FWV	4-Way Valve
8	HPXWSEE50WFW	Water Flow Switch
9	HPXWSEE50FM	Fan Motor
10	HPXWSEE50FMC	Fan Motor Capacitor
11	HPXWSEE40FUS	Fuse
12	HPXWSEE50TMP	Full set of sensors
13	HPXWSEE40CCC	Compressor
14	HPXWSEE40THE	Titanium Heat Exchanger
15	HPXWSEE40E	Evaporator
16	HPXWSEE50PPS	High & Low Pressure Protection Switch
17	HPXWSEE50PV	High & Low Pressure Valve
18	HPXWSEE50WN	Water Union
19	HPXWSEE50WMG	Water Union Gasket
20	HPXWSEE40F	Fan
21	HPXWSEE50DTJ	Drainage Kit
22	HPXWSEE50ICC	Compressor Insulation Cap
23	HPXWSEE50CAB	Top Cover
24	HPXWSEE50CAB	Front Panel
25	HPXWSEE50CAB	Right Panel
26	HPXWSEE40CAB	Back Panel
27	HPXWSEE50BB	Bottom Board

HP40BEE, HP50BEE, HP65BEE1

HEAT PUMP REPLACEMENT PARTS

HP50BEE

Ref. No.	Part No.	Description
1	HPXWSEE50CDM	Inverter Board
2	HPXWSEE50PCB	PC Board
3	HPXWSEE50IL	Oval LED
4	HPXWSEE50PPF	Power Filter Plate
5	HPXWSEE50IN	Inductor
6	HPXWSEE50EV	Electronic Expansion Valve
7	HPXWSEE50FWV	4-Way Valve
8	HPXWSEE50WFW	Water Flow Switch
9	HPXWSEE50FM	Fan Motor
10	HPXWSEE50FMC	Fan Motor Capacitor
11	HPXWSEE50FUS	Fuse
12	HPXWSEE50TMP	Full set of sensors
13	HPXWSEE50CCC	Compressor
14	HPXWSEE50THE	Titanium Heat Exchanger
15	HPXWSEE50E	Evaporator
16	HPXWSEE50PPS	High & Low Pressure Protection Switch
17	HPXWSEE50PV	High & Low Pressure Valve
18	HPXWSEE50WN	Water Union
19	HPXWSEE50WVG	Water Union Gasket
20	HPXWSEE50F	Fan
21	HPXWSEE50DTJ	Drainage Kit
22	HPXWSEE50ICC	Compressor Insulation Cap
23	HPXWSEE50CAB	Top Cover
24	HPXWSEE50CAB	Front Panel
25	HPXWSEE50CAB	Right Panel
26	HPXWSEE50CAB	Back Panel
27	HPXWSEE50BB	Bottom Board

HP65BEE1

Ref. No.	Part No.	Description
1	HPXWSEE65CDM1	Inverter Board
2	HPXWSEE50PCB	PC Board
3	HPXWSEE50IL	Oval LED
4	HPXWSEE50PPF	Power Filter Plate
5	HPXWSEE65IN1	Inductor
6	HPXWSEE50EV	Electronic Expansion Valve
7	HPXWSEE65FWV	4-Way Valve
8	HPXWSEE50WFW	Water Flow Switch
9	HPXWSEE50FM	Fan Motor
10	HPXWSEE50FMC	Fan Motor Capacitor
11	HPXWSEE65FUS	Fuse
12	HPXWSEE50TMP	Full set of sensors
13	HPXWSEE65CCC1	Compressor
14	HPXWSEE65THE1	Titanium Heat Exchanger
15	HPXWSEE65E	Evaporator
16	HPXWSEE50PPS	High & Low Pressure Protection Switch
17	HPXWSEE50PV	High & Low Pressure Valve
18	HPXWSEE50WN	Water Union
19	HPXWSEE50WVG	Water Union Gasket
20	HPXWSEE40F	Fan
21	HPXWSEE50DTJ	Drainage Kit
22	HPXWSEE65ICC	Compressor Insulation Cap
23	HPXWSEE65CAB	Top Cover
24	HPXWSEE65CAB	Front Panel
25	HPXWSEE65CAB	Right Panel
26	HPXWSEE65CAB	Back Panel
27	HPXWSEE50BB	Bottom Board