

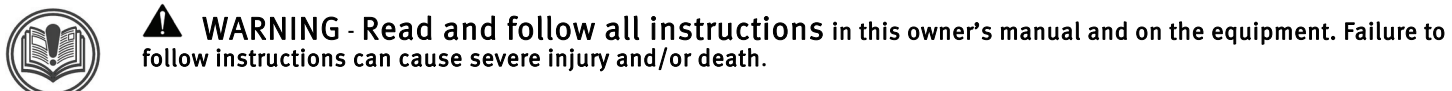

FRONT ACCESS SKIMMER

Owner's Manual Vinyl Pools



SP1092 FRONT ACCESS SKIMMER

The SP1092 Skimmer for above ground pools allows the choice between a standard wall punch hole mounting or outside mounting.

INSTALLATION INSTRUCTIONS (Standard Hole Mounting Punch)

1. Drill or punch twelve (12) 1/4" holes per dimensions on page 4. Make the rectangular cut-out per inside skimmer body face dimensions (5 7/8" wide x 5 5/8" tall).
2. Place gasket on skimmer face, making sure holes in gasket align with holes in skimmer face. (A very light application of adhesive cement will assist in holding gasket in place.)
3. Align skimmer face and gasket with drilled panel holes and fasten to wall panel at center side holes with the two 5/8" long pan head securing screws. Be sure to tape the screw heads to prevent damage to the vinyl liner.
4. If vinyl liner pool, install liner before proceeding with Step 5.
5. Align second gasket and face plate and fasten tightly to skimmer face with ten (10) 1" long screws. Use a large Phillips head screwdriver to drive these heavy duty screws. If vinyl liner pool, pierce liner through face plate holes one at a time prior to inserting screws. Screws go through and secure: the Face Plate, Gasket vinyl Liner, the Wall Panel, through the Gasket and finally into Skimmer Face.
6. If vinyl liner pool, cut out liner along **inside** edges of face plate.

INSTALLATION INSTRUCTIONS (Outside Mounting)

1. The pool wall must be cut to closely fit, but slightly larger than the 7 5/8" wide by 7 1/8" tall skimmer body throat.
2. Insert the skimmer into the pool wall cut-out from the rear until the face of the skimmer is flush with the inside wall of the pool. The flange face on the outside of the pool wall may need spacers. The flange is 3/4" recessed from the face of the skimmer. Predrill flange mounting pilot holes with an 11/64" drill.
3. Align the outside mounting holes and secure with 5/8" long screws supplied.
4. Place gasket on skimmer face, making sure holes in gasket align with holes in skimmer face. (A very light application of adhesive cement will assist in holding gasket in place.)
5. Install the vinyl liner in the pool.
6. Align second gasket and face plate and fasten tightly to skimmer face with ten (10) 1" long screws. Use a large Phillips head screwdriver to drive these heavy duty screws. If vinyl liner pool, pierce liner through face plate holes one at a time prior to inserting screws.
7. Cut out liner along **inside** edges of face plate.

IMPORTANT SAFETY INSTRUCTIONS

Hayward Pool Products
620 Division Street, Elizabeth, NJ 07207
Phone: (908) 355-7995
www.hayward.com



Basic safety precautions should always be followed, including the following: Failure to follow instructions can cause severe injury and/or death.

- ▲ This is the safety-alert symbol. When you see this symbol on your equipment or in this manual, look for one of the following signal words and be alert to the potential for personal injury.
- ▲ **WARNING** warns about hazards that **could** cause serious personal injury, death or major property damage and if ignored presents a potential hazard.
- ▲ **CAUTION** warns about hazards that **will** or **can** cause minor or moderate personal injury and/or property damage and if ignored presents a potential hazard. It can also make consumers aware of actions that are unpredictable and unsafe.

The **NOTICE** label indicates special instructions that are important but not related to hazards.

▲ **WARNING – Suction Entrapment Hazard.**

Suction in suction outlets and/or suction outlet covers which are, damaged, broken, cracked, missing, or unsecured can cause severe injury and/or death due to the following entrapment hazards:



Hair Entrapment- Hair can become entangled in suction outlet cover.



Limb Entrapment- A limb inserted into an opening of a suction outlet sump or suction outlet cover that is damaged, broken, cracked, missing, or not securely attached can result in a mechanical bind or swelling of the limb.



Body Suction Entrapment- A negative pressure applied to a large portion of the body or limbs can result in an entrapment.

Evisceration/ Disembowelment - A negative pressure applied directly to the intestines through an unprotected suction outlet sump or suction outlet cover which is, damaged, broken, cracked, missing, or unsecured can result in evisceration/ disembowelment.



Mechanical Entrapment- There is potential for jewelry, swimsuit, hair decorations, finger, toe or knuckle to be caught in an opening of a suction outlet cover resulting in mechanical entrapment.

▲ **WARNING - To Reduce the risk of Entrapment Hazards:**

- When outlets are small enough to be blocked by a person, a minimum of two functioning suction outlets per pump must be installed. Suction outlets in the same plane (i.e. floor or wall), must be installed a minimum of three feet (3') [1 meter] apart, as measured from near point to near point.
- Dual suction fittings shall be placed in such locations and distances to avoid “dual blockage” by a user.
- Dual suction fittings shall not be located on seating areas or on the backrest for such seating areas.
- Never use Pool or Spa if any suction outlet component is damaged, broken, cracked, missing, or not securely attached.
- Replace damaged, broken, cracked, missing, or not securely attached suction outlet components immediately.
- In addition two or more suction outlets per pump installed in accordance with latest ASME, APSP Standards and CPSC guidelines, follow all National, State, and Local codes applicable.
- Installation of a vacuum release or vent system, which relieves entrapping suction, is recommended.

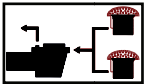

▲ **WARNING – Failure to remove pressure test plugs and/or plugs used in winterization of the pool/spa from the suction outlets can result in an increase potential for suction entrapment as described above.**

▲ **WARNING – Failure to keep suction outlet components clear of debris, such as leaves, dirt, hair, paper and other material can result in an increase potential for suction entrapment as described above.**

▲ **WARNING – Suction outlet components have a finite life, the cover/grate should be inspected frequently and replaced at least every seven years or if found to be damaged, broken, cracked, missing, or not securely attached.**

▲ **CAUTION – Components such as the filtration system, pumps and heater must be positioned so as to prevent their being used as means of access to the pool by young children.** To reduce risk of injury, do not permit children to use or climb on this product. Closely supervise children at all times. Components such as the filtration system, pumps, and heaters must be positioned to prevent children from using them as a means of access to the pool.



▲ **WARNING – Hazardous Pressure.** Pool and spa water circulation systems operate under hazardous pressure during start up, normal operation, and after pump shut off. Stand clear of circulation system equipment during pump start up. Failure to follow safety and operation instructions could result in violent separation of the pump housing and cover, and/or filter housing and clamp due to pressure in the system, which could cause property damage, severe personal injury, or death. Before servicing pool and spa water circulation system, all system and pump controls must be in off position and filter manual air relief valve must be in open position. Before starting system pump, all system valves must be set in a position to allow system water to return back to the pool. Do not change filter control valve position while system pump is running. Before starting system pump, fully open filter manual air relief valve. Do not close filter manual air relief valve until a steady stream of water (not air or air and water) is discharged.



▲ **WARNING – Separation Hazard.** Failure to follow safety and operation instructions could result in violent separation of pump and/or filter components. Strainer cover must be properly secured to pump housing with strainer cover lock ring. Before servicing pool and spa circulation system, filters manual air relief valve must be in open position. Do not operate pool and spa circulation system if a system component is not assembled properly, damaged, or missing. Do not operate pool and spa circulation system unless filter manual air relief valve body is in locked position in filter upper body. **Never operate or test the circulation system at more than 50 PSI. Do not purge the system with compressed air.** Purging the system with compressed air can cause components to explode, with risk of severe injury or death to anyone nearby. Use only a low pressure (below 5 PSI), high volume blower when air purging the pump, filter, or piping.



HAYWARD®



⚠ WARNING – Risk of Electric Shock. All electrical wiring **MUST** be in conformance with applicable local codes, regulations, and the National Electric Code (NEC). Hazardous voltage can shock, burn, and cause death or serious property damage. To reduce the risk of electric shock, do **NOT** use an extension cord to connect unit to electric supply. Provide a properly located electrical receptacle. Before working on any electrical equipment, turn off power supply to the equipment. To reduce the risk of electric shock replace damaged wiring immediately. Locate conduit to prevent abuse from lawn mowers, hedge trimmers and other equipment. Do **NOT** ground to a gas supply line.

⚠ WARNING – Risk of Electric Shock Failure to ground all electrical equipment can cause serious or fatal electrical shock hazard. Electrical ground all electrical equipment before connecting to electrical power supply.

⚠ WARNING – Risk of Electric Shock Failure to bond all electrical equipment to pool structure will increase risk for electrocution and could result in injury or death. To reduce the risk of electric shock, see installation instructions and consult a professional electrician on how to bond all electrical equipment. Also, contact a licensed electrician for information on local electrical codes for bonding requirements.

Notes to electrician: Use a solid copper conductor, size 8 or larger. Run a continuous wire from external bonding lug to reinforcing rod or mesh. Connect a No. 8 AWG (8.4 mm²) [No. 6 AWG (13.3 mm²) for Canada] solid copper bonding wire to the pressure wire connector provided on the electrical equipment and to all metal parts of swimming pool, spa, or hot tub, and metal piping (except gas piping), and conduit within 5 ft. (1.5 m) of inside walls of swimming pool, spa, or hot tub.

IMPORTANT - Reference NEC codes for all wiring standards including, but not limited to, grounding, bonding and other general wiring procedures.

⚠ WARNING – Risk of Electric Shock . The electrical equipment must be connected only to a supply circuit that is protected by a ground-fault circuit-interrupter (GFCI). Such a GFCI should be provided by the installer and should be tested on a routine basis. To test the GFCI, push the test button. The GFCI should interrupt power. Push reset button. Power should be restored. If the GFCI fails to operate in this manner, the GFCI is defective. If the GFCI interrupts power to the electrical equipment without the test button being pushed, a ground current is flowing, indicating the possibility of an electrical shock. Do not use this electrical equipment. Disconnect the electrical equipment and have the problem corrected by a qualified service representative before using.

⚠ CAUTION – HAYWARD® pumps are intended for use with permanently-installed pools and may be used with hot tubs and spas if so marked. Do not use with storable pools. A permanently-installed pool is constructed in or on the ground or in a building such that it cannot be readily disassembled for storage. A storable pool is constructed so that it is capable of being readily disassembled for storage and reassembled to its original integrity.

⚠ WARNING – Risk of Hyperthermia. To avoid hyperthermia the following “Safety Rules for Hot Tubs” are recommended by the U.S. Consumer Product Safety Commission.

1. Spa or hot tub water temperatures should never exceed 104°F [40°C]. A temperature of 100°F [38°C] is considered safe for a healthy adult. Special caution is suggested for young children. Prolonged immersion in hot water can induce hyperthermia.
2. Drinking of alcoholic beverages before or during spa or hot tub use can cause drowsiness, which could lead to unconsciousness and subsequently result in drowning.
3. Pregnant women beware! Soaking in water above 100°F [38°C] can cause fetal damage during the first three months of pregnancy (resulting in the birth of a brain-damaged or deformed child). Pregnant women should adhere to the 100°F [38°C] maximum rule.
4. Before entering the spa or hot tub, users should check the water temperature with an accurate thermometer; spa or hot tub thermostats may err in regulating water temperatures by as much as 4°F (2.2°C).
5. Persons taking medications, which induce drowsiness, such as tranquilizers, antihistamines or anticoagulants, should not use spas or hot tubs.
6. If the pool/spa is used for therapy, it should be done with the advice of a physician. Always stir pool/ spa water before entering the pool/spa to mix in any hot surface layer of water that might exceed healthful temperature limits and cause injury. Do not tamper with controls, because scalding can result if safety controls are not in proper working order.
7. Persons with a medical history of heart disease, circulatory problems, diabetes or blood pressure problems should obtain a physicians advice before using spas or hot tubs.
8. Hyperthermia occurs when the internal temperature of the body reaches a level several degrees above normal body temperature of 98.6°F [37°C]. The symptoms of Hyperthermia include: drowsiness, lethargy, dizziness, fainting, and an increase in the internal temperature of the body.

The effects of Hyperthermia include:

1. Unawareness of impending danger.
2. Failure to perceive heat.
3. Failure to recognize the need to leave the spa.
4. Physical inability to exit the spa.
5. Fetal damage in pregnant women.
6. Unconsciousness resulting in danger of drowning.

SAVE THESE INSTRUCTIONS



HAYWARD®

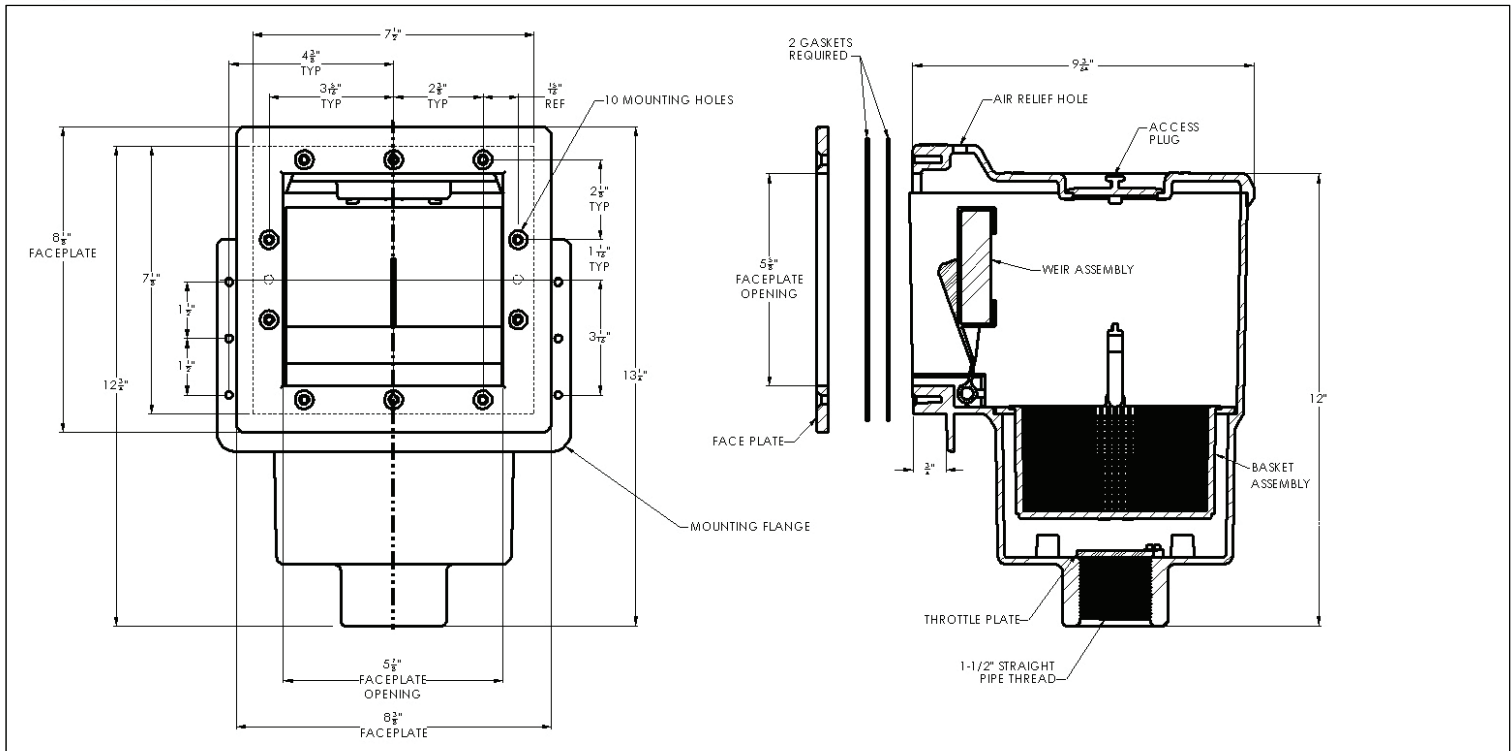

INSTRUCTIONS: TO CLEAN SKIMMER BASKET

Fold the weir forward and squeeze pins toward center to remove weir. Remove and clean basket.

For hose connection to the port: Wrap two full wraps of TFE tape on the male thread of the SP1091Z7. Install in the outlet.

Deluxe Skim-Vac Accessory

SKIM-VAC attaches to vac hose and is inserted in skimmer over basket, allowing you to conveniently vacuum through the skimmer basket.

TO VACUUM WITH SKIM-VAC

1. Remove weir from front of skimmer.
2. Attach vacuum hose to vac head and handle, and fill vacuum hose with water (place over pool inlet). When full, place hose end on SKIM-VAC and place SKIM-VAC over skimmer basket.
3. Hold SKIM-VAC in place until any air in hose is evacuated by pump. Once air is removed, the pump suction will hold the SKIM-VAC firmly in place.

TO ATTACH VACUUM CLEANER HOSE (Without Skim Vac)

Remove top cover; or pull weir forward and squeeze pins toward center to remove weir. Remove basket. Fill hose with water and insert vacuum hose cuff into skimmer outlet. If adapter is required; first screw adapter into skimmer outlet then press on vacuum hose.

NOTE: Take care not to damage or scuff up SKIM-VAC's specially designed sealing surface.

SPARE PARTS

| Part Number | Description | QTY |
|-------------|---|-----|
| SPX1096CA | BASKET ASSEMBLY | 1 |
| SPX1094K | WEIR | 1 |
| SPX1096A2 | BASKET RING | 1 |
| SPX1090D | FACE PLATE | 1 |
| SPX1094G | GASKET | 2 |
| SPX1090Z1A | FACE PLATE SCREW SET (12 SCREW SET) | 1 |
| SPX1411Z3B | SCREW SET (6 screws 5/8" long) | 1 |
| SPX1092C | ACCESS PLUG, 1/4 TURN | 1 |
| SP1094D | SKIM VAC | |
| SPX1091Z7 | MALE COMBO ADAPTER (NPT TO 1 1/2" HOSE) | |