

⚠ WARNING: FOR YOUR SAFETY - This product must be installed and serviced by a professional service technician, qualified in pool heater installation. Improper installation and/or operation could create carbon monoxide gas in flue gases which could cause serious injury, property damage, or death. For indoor installations, as an additional measure of safety, Waterpik Technologies strongly recommends installation of suitable Carbon Monoxide detectors in the vicinity of this appliance and in any adjacent occupied spaces. Improper installation and/or operation will void the warranty.

Installation and Operation Manual

Lite2™ Pool and Spa Heater

Model LG Natural Gas or LP Gas

This product is manufactured under the following listed
United States patents: 3,446,566 - 4,461,274 - 4,421,270 -
5,117,233 - 5,163,508 - Other patents pending

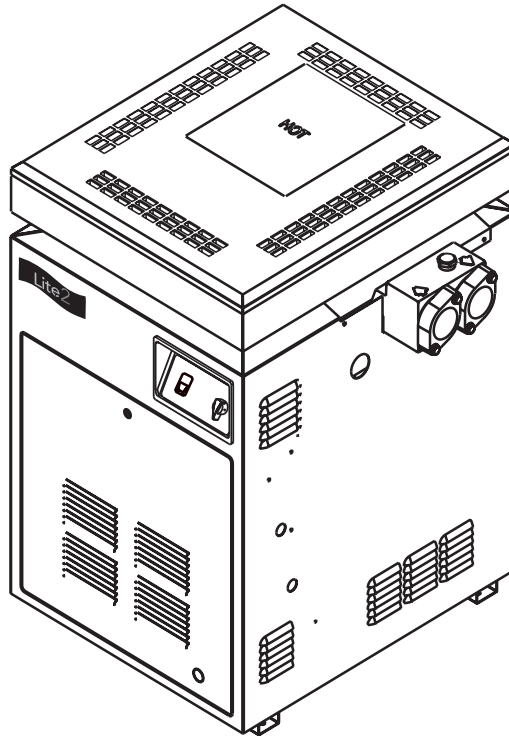

⚠ WARNING: If these instructions are not followed exactly, a fire or explosion may result, causing property damage, personal injury, or death.

Do not store or use gasoline or other flammable vapors and liquids in the vicinity of this or any other appliance.

WHAT TO DO IF YOU SMELL GAS

- Do not try to light any appliance.
- Do not touch any electrical switch; do not use any phone in your building.
- Immediately call your gas supplier from a nearby phone. Follow the gas supplier's instructions.
- If you cannot reach your gas supplier, call the fire department.

Installation and service must be performed by a qualified installer, service agency, or the gas supplier.

TABLE OF CONTENTS

SECTION 1.

General Information

1.1	Introduction	1
1.2	Consumer Information and Safety	1
1.2.1	Spa/Hot Tub Safety Rules	1
1.2.2	Swimming Pool Energy Saving Tips	2
1.3	Warranty	2
1.4	Codes and Standards	2
1.5	Technical Assistance	2
1.6	Materials Installer Must Provide	3
1.6.1	Materials For All Installations	3
1.6.2	Materials For Special Installations	3
1.7	Specifications	3
1.7.1	General Specifications	3
1.7.2	Dimensions	4

SECTION 2.

Installation Instructions

2.1	Introduction	4
2.2	Field Assembly	4
2.3	Location Requirements	4
2.3.1	Introduction	4
2.3.2	Clearances	5
2.3.3	Flooring	6
2.3.4	Outdoor Installation	6
2.3.5	Indoor and Outdoor Shelter Installation	7

SECTION 3.

Venting

3.1	Combustion Air Supply	7
3.2	Vent Pipe Sizing and General Installation	9
3.2.1	Outdoor Installations	9
3.2.2	Indoor and Outdoor Shelter Installations	9
3.2.3	Inspection and Replacement of Existing Vent System with New Components	10

SECTION 4.

Gas Connections

4.1	Gas Supply and Piping	10
4.2	Manifold Pressure	11
4.3	Special Precautions for Propane Gas	12

SECTION 5.

Water Connections

5.1	Water Piping	12
5.2	Check Valve Installation	13
5.3	Automatic Flow Control Valve	13
5.4	Reversible Water Connections	13
5.5	Connections at Heater	15
5.6	Pressure Relief Valve	16
5.7	Auxiliary Components, Chlorinators, Ozone Generators and Sanitizing Chemicals	16

SECTION 6.

Electrical Connection

6.1	Main Power	17
-----	------------------	----

6.2	Bonding	17
6.3	Auxiliary Time Clock Wiring	17

SECTION 7.

Operating Instructions

7.1	Normal Operation	17
7.2	Start -Up	19
7.3	Lighting and Shutdown Procedures	20
7.4	Turning the Heater On/Off and Setting the Temperature Control	20
7.5	Water Pressure Switch Adjustment	22
7.6	Temperature Rise	22
7.7	Adjusting the Manual Bypass Valve	23

SECTION 8.

Maintenance

8.1	Water Chemistry	23
8.2	Seasonal Care	24
8.2.1	Spring and Autumn Operation	24
8.2.2	Winterizing	25
8.2.3	Spring Start-up	25
8.3	Inspections and Service	25
8.3.1	Owner Inspection	25
8.3.2	Professional Inspection	26

SECTION 9.

Trouble Shooting

9.1	General Heater Trouble Shooting	27
9.2	Trouble Shooting Guide	27

SECTION 10.

Professional Maintenance, Service and Diagnostic Trouble Shooting

10.1	General Information	28
10.2	Natural Draft Combustion System	28
10.3	Heater Components And Their Operation	28
10.4	Electrical Trouble Shooting	29
10.4.1	Gas Valve	30
10.4.2	Pilot Generator	30
10.4.3	Fusible Link	30
10.4.4	Fireman switch and External Interlocks	31
10.4.5	Limit Switches	31
10.4.6	Water Pressure Switch	32
10.4.7	Temperature Control Circuit	32
10.4.7.1	ON/OFF Toggle Switch	32
10.4.7.2	Variable Temperature Control	32
10.4.7.3	Temperature Sensor	32
10.4.7.4	Temperature Control Circuit Board	32

SECTION 11.

Replacement Parts

11.1	Ordering Information	34
11.2	Parts List	34
11.3	General Exploded View	36
11.4	Detailed Exploded View	37
	Warranty	Back Cover

SECTION 1. General Information

1.1 Introduction

This manual provides installation and operation instructions for the Lite2 Model LG pool and spa heater. Read these installation and operation instructions completely before proceeding with the installation. Consult the Jandy factory, or local factory representative, with any questions regarding this equipment.

Certain sections of this manual are specific to either United States or Canadian installations, and are labeled as such.

The Lite2 model LG heater is a self contained standing pilot unit and requires no external power.

The Lite2 heater is specifically designed for heating fresh water swimming pools and spas, and with proper installation and care, they will provide years of reliable service. Do not use the heater to maintain pool or spa water temperature below 70°F. Do not use it as a heating boiler or general service water heater or to heat salt water. Consult your dealer for the appropriate Jandy products for these applications.

1.2 Consumer Information and Safety

The Lite2 Pool/Spa heater is designed and manufactured to provide many years of safe and reliable service when installed, operated and maintained according to the information in this manual and the installation codes referred to in later sections. Throughout the manual safety warnings and cautions are identified by the "⚠" symbol. Be sure to read and comply with all of the warnings and cautions.

1.2.1 Spa/Hot Tub Safety Rules

⚠ WARNING

The following "Safety Rules for Hot Tubs," recommended by the U.S. Consumer Product Safety Commission, should be observed when using the spa.

⚠ AVERTISSEMENT

Les Règlements suivants pour Cuves Thermales, tel que recommandés par la Commission U.S. de Sécurité des Produits pour les Consommateurs, devraient être respectés lors de l'utilisation du spa.

⚠ WARNING

The U.S. Consumer Product Safety Commission warns that elevated water temperature can be hazardous. Consult heater operation and installation instructions for water temperature guidelines before setting temperature.

⚠ AVERTISSEMENT

La U.S. Consumer Product Safety Commission indique que des températures de l'eau élevées peuvent être dangereuses. Voir la notice d'installation et de fonctionnement pour le réglage de la température.

1. Spa or hot tube water temperature should never exceed 104°F (40°C). One hundred degrees Fahrenheit (100°F [38°C]) is considered safe for a healthy adult. Special caution is recommended for young children.
2. The drinking of alcoholic beverages before or during spa or hot tub use can cause drowsiness which could lead to unconsciousness, and subsequently result in drowning.
3. **Pregnant women take note!** Soaking in water above 102°F (38.5°C) can cause fetal damage during the first three months of pregnancy (which could result in the birth of a brain-damaged or deformed child). If pregnant women are going to use a spa or hot tub, they should make sure the water temperature is below 100°F (38°C) maximum.
4. The water temperature should always be checked with an accurate thermometer before entering a spa or hot tub. Temperature controls may vary by as much as 4F° (2C°).
5. Persons with a medical history of heart disease, diabetes, circulatory or blood pressure problems should consult their physician before using a hot tub or spa.
6. Persons taking any medication which induces drowsiness (e.g., tranquilizers, antihistamines, or anticoagulants) should not use spas or hot tubs.
7. Prolonged immersion in hot water can induce hyperthermia.

Hyperthermia occurs when the internal body temperature reaches a level several degrees above the normal body temperature of 98.6°F (37°C). Symptoms include dizziness, fainting, drowsiness, lethargy, and

an increase in the internal body temperature. The effects of hyperthermia include:

- Lack of awareness of impending hazard
- Failure to perceive heat
- Failure to recognize need to leave spa
- Physical inability to leave spa
- Fetal damage in pregnant women
- Unconsciousness resulting in a danger of drowning

1.2.2 Swimming Pool Energy Saving Tips

Water Pik Technologies offers the following recommendations to help conserve fuel and minimize the cost of operating your pool heater without sacrificing comfort.

1. The American Red Cross recommends a maximum water temperature of 78°F (25°C). Use an accurate pool thermometer. A difference of 4F° (2C°), between 78°F and 82°F (26°C and 28°C), will use as much as 40% more gas.
2. Carefully monitor the water temperature of your pool in the summertime. You can reduce heater usage due to warmer air temperatures.
3. Find the proper setting on the pool heater temperature control and use the TEMP-LOK to discourage further adjustments.
4. Set the filter time clock to start the pump no earlier than 6:00 AM during the pool heating season. This is the time when nightly heat loss balances.
5. If the pool is only going to be used on weekends, reduce the heater temperature control setting by 8 or 10 degrees during the week. Reset it to the desired temperature level a day or so before you plan to use the pool.
6. During the winter or when on vacation for longer than a week, shut down the heater by following the shutdown instructions found on the inside of the heater.
7. Where possible, shelter the pool from prevailing winds with well-trimmed hedges or other landscaping, cabanas, or fencing.
8. Always use a pool cover when practical. Besides providing a valuable safety feature, a pool cover will reduce heat loss, conserve chemicals, and reduce the load on filter systems.

1.3 Warranty

The Lite2 heater is sold with a limited factory warranty. Details are specified on the back cover of this manual.

Make all warranty claims to an authorized Jandy representative or directly to the factory. Claims must include the heater serial number and model (this information can be found on the rating plate), installation date, and name of the installer. Shipping costs are not included in the warranty coverage.

The warranty does not cover damage caused by improper assembly, installation, operation or field modification. Also, damage to the heat exchanger by corrosive water, is NOT covered by the warranty. See Section 8.1 for maintaining proper pool water chemistry.

NOTE: Keep this manual in a safe place for future reference when inspecting or servicing the heater.

1.4 Codes and Standards

The Lite2 pool and spa heater is design certified by CSA (Canadian Standards Association) as complying with the latest edition of the “Standard for Gas Fired Pool Heaters”, ANSI Z21.56 in the USA and CSA-4.7 in Canada.

All Jandy heaters must be installed in accordance with the local building and installation codes as per the utility or authorities having jurisdiction. All local codes take precedence over national codes.

In the absence of local codes, refer to the latest edition of the following national codes for installation:

1. In the United States, “The National Fuel and Gas Code”, ANSI Z223.1. Pay special attention to the section covering, “Venting of Equipment”.
2. In Canada, “The Natural Gas and Propane Installation Code”, CAN/CSA-B149.1.

Any changes to the heater, gas controls, gas orifices, wiring, draft diverter, or improper installation may void the warranty. If change is required to any of the above, consult the factory.

1.5 Technical Assistance

Consult Water Pik Technologies or your local Jandy distributor with any questions or problems involving the specifications, installation, and operation of your Jandy equipment. An experienced technical support staff is ready to assist you in assuring the proper performance and application of Jandy products. For technical support call the Jandy Products Technical Service Department at (707) 776-8200 extension 260.

1.6 Materials Installer Must Provide

1.6.1 Materials For All Installations

The following items are needed and are to be supplied by the installer for *all* Lite2 heater installations:

1. The correct size gas pipe to supply gas from the meter to the heater (see Section 4.1 for correct gas pipe size).
2. A manually operated gas valve to be installed in the gas line outside of the heater.
3. A suitable gas union joint to connect the heater to the gas line.
4. Plumbing items needed to provide a sediment trap (drip leg) in the gas line between the manual gas valve and the union to the heater (see Section 4.1).

1.6.2 Materials For Special Installations

In addition to the items listed above, the following items are needed for special applications.

1. A factory authorized draft hood and vent pipe for indoor installations in the USA and outdoor shelter installations in Canada (see Section 3.2.2). Draft hoods are available from any Jandy distributor.
2. Primer and cement suitable for cementing CPVC pipe to PVC pipe and an appropriate coupling for connecting the factory supplied CPVC pipe nipples to PVC pool plumbing.
3. A non combustible platform for installation on combustible surfaces (see Section 2.3.3). Non combustible bases are available from your Jandy distributor.
4. A factory approved vent cap for all outdoor installations where wind conditions may cause downdrafting. Vent caps are available from your Jandy distributor.

1.7 Specifications

1.7.1 General Specifications

1. Installation Location.
 Certified for use:
 In the USA:
 Natural Gas: Indoor and Outdoor
 LP Gas: Indoor and Outdoor
 In Canada:
 Natural Gas: Outdoor Shelter and Outdoor
 LP Gas: Outdoor Shelter and Outdoor

2. Minimum Clearance From Combustible Material: See Table 2 in Section 2.3.2
3. *Gas Pipe/Heater Gas Valve Connection.
 Natural Gas: 3/4" NPT
 LP Gas: 3/4" NPT
 *For diameter of gas line from meter to heater see Table 3 in Section 4.1.
4. Supply Gas Type.
 Certified for use with:
 Natural Gas or Liquefied Petroleum Gas (LP Gas or Propane Gas).
5. Inlet Gas Supply Pressure.

	Minimum	Maximum
Natural Gas:	5.5 "WC	10.0 "WC
LP Gas:	10.0 "WC	14.0 "WC
6. Water Pipe/Heater Connection†.

	Threaded	Unthreaded
Iron Pipe	2" NPT	1 1/2"*
Copper Pipe		1 1/2" or 2"*
Plastic	2" NPT**	2"

† Connections shown here are common sizes. Other sizes may be connected (see Sections 5.5 for details).
 * Unthreaded 1 1/2" pipe or 2" pipe maybe used with special seals included with this heater.
 ** Threaded 2" CPVC nipples are supplied with the heater for connecting 2" PVC pipe.
7. Flow Rate:
 Maximum: 125 gpm (475 lpm)
 Minimum: 30 gpm (110 lpm)
8. Maximum Working Water Pressure: 75 psi
9. Exhaust Vent Connection Size: See Figure 1 in Section 1.7.2, "Dimensions".
10. Electrical Supply: None (the LG heater is a millivolt heater with a standing pilot ignition).
11. Modification of Heater for High Altitude:
 The Lite 2 model LG heater is normally shipped from the factory in the low altitude (sea level) operational configuration. When requested, the heaters can be configured and shipped for higher altitudes. For field conversions to change altitude configurations, manifold kits for mid altitudes and high altitudes are available from your Jandy pool products dealer or by contacting the Customer Service Department at (707) 776-8200 extension 245. See Section 11, "Parts List", of this manual for the correct kit number for the manifold assembly needed for your altitude. Table 1 defines the altitude designations as described by the "Standard for Gas Fired Pool Heaters", ANSI Z21.56 in the United States and "Gas Fired Appliances For Use At High Altitudes", CAN 1-2.17 in Canada.

Table 1. Altitude Designations for the Lite2 Heater.

NATURAL GAS		
ALTITUDE DESIGNATION	UNITED STATES	CANADA
LOW ALTITUDE	0-3000 FT	0-2000 FT (0-610 m)
MID ALTITUDE	3001-6000 FT	2001-4500 FT (611-1370 m)
HIGH ALTITUDE	6001-10,000 FT	NOT APPLICABLE
LP		
LOW ALTITUDE	0-5000 FT	0-4500 FT (0-1370 m)
HIGH ALTITUDE	5001-10,000 FT	NOT APPLICABLE

1.7.2 Dimensions

See Figure 1 (following page) for a diagram showing the heater's exterior dimensions and dimensions to critical connections on the heater.

SECTION 2. Installation Instructions

⚠ WARNING

Improper installation or maintenance can cause nausea or asphyxiation from carbon monoxide in flue gases which could result in severe injury, or death. For indoor installations, as an additional measure of safety, Waterpik Technologies strongly recommends installation of suitable Carbon Monoxide detectors in the vicinity of this appliance and in any adjacent occupied spaces.

⚠ AVERTISSEMENT

Une installation ou un entretien inadéquat peut causer la nausée ou l'asphyxie en raison du monoxyde de carbone présent dans les gaz de combustion et même entraîner des blessures graves ou la mort. Pour les installations intérieures, comme mesure de sécurité additionnelle, Waterpik Technologies recommande fortement l'installation de détecteurs de monoxyde de carbone près de cet appareil ainsi que dans les espaces adjacents occupés.

2.1 Introduction

Install the Lite2 heaters, vent caps and drafthoods in accordance with the procedures in this manual, local codes and ordinances, and in accordance with the latest edition of the appropriate national code

(see Section 1.4 "Codes and Standards").

All gas-fired products require correct installation to assure safe operation. The requirements for pool heaters include the following:

1. Field assembly (if required)
2. Appropriate site location (clearances) and flooring
3. Sufficient combustion and ventilation air
4. Properly sized gas meter and piping
5. Proper electrical wiring (if required)
6. Adequate water flow

This manual provides the information needed to meet these requirements. Review all application and installation procedures completely before continuing the installation.

2.2. Field Assembly

The Lite2 heater is shipped from the factory with the top assembly in the low-profile configuration for outdoor installation. The Lite2 heater is design certified for indoor installation (U.S. only) when equipped with a drafthood, which must be installed without modification.

The Lite2 heater is also certified for installation in an outdoor shelter in Canada when equipped with a drafthood. An outdoor shelter is an enclosure not normally occupied which does not communicate directly with occupied areas.

Check the rating plate on the heater or the Parts List (Section 11) of this manual for the correct Jandy drafthood or vent cap part number. See instructions supplied with the drafthood or vent cap for installation and attachment. When the drafthood is used, locate the heater so as to be in the same atmospheric pressure zone as the combustion air inlet to the heater.

2.3 Location Requirements

2.3.1 Introduction

⚠ CAUTION

When pool equipment is located below the pool surface, a leak from any component can cause large scale water loss or flooding. Water Pik Technologies cannot be responsible for such water loss or flooding or resulting damage.

⚠ ATTENTION

Lorsque l'équipement d'une piscine est situé sous la surface de l'eau, une fuite provenant de n'importe quel élément peut causer une perte d'eau importante ou une inondation. Water Pik Technologies n'est pas responsable des pertes d'eau, des inondations ou des avaries causées par une installation ou un entretien inadéquat.

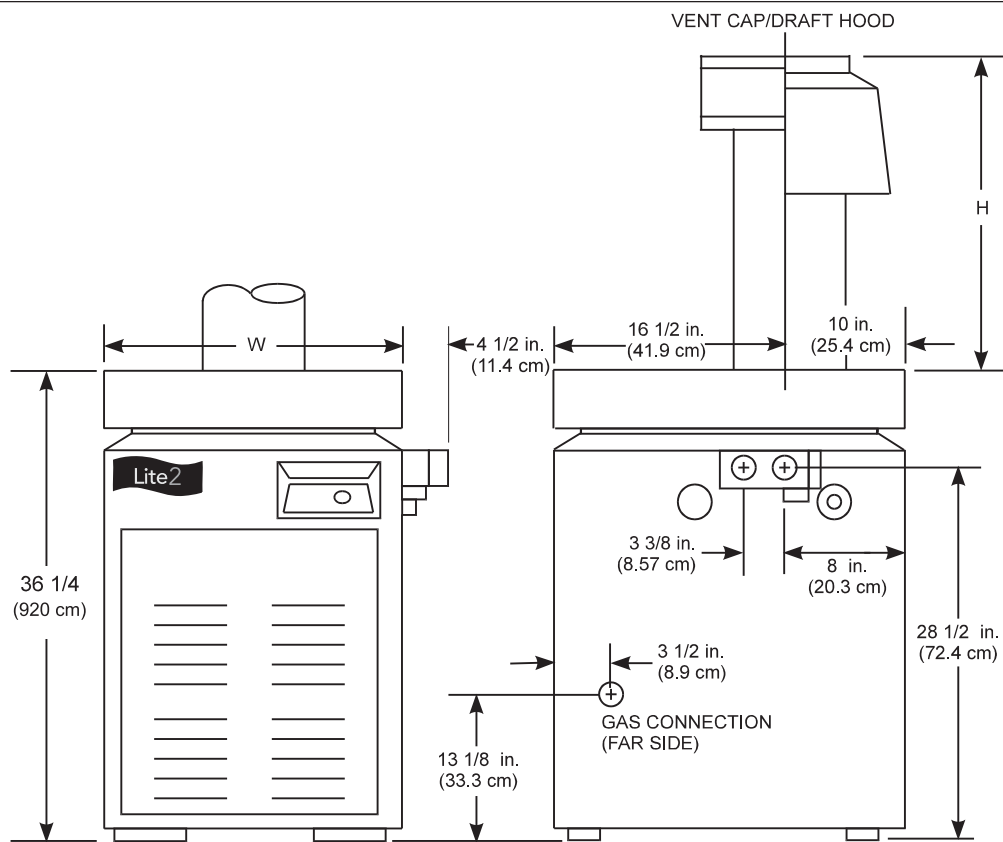

Model	Heater Width	Venting Dimensions				Firing Rate / Hr.* (1,000's)
		Vent Diameter		Outdoor Dim "H"		
	in (cm)	in (cm)	in (cm)	in (cm)	in (cm)	BTU (kcal)
LG125	15 (38)	5 (13)	17 3/8 (44)	16 1/4 (41)	125 (32)	
LG175	18 (46)	6 (15)	18 (46)	24 1/8 (61)	175 (44)	
LG250	22 1/2 (57)	7 (18)	18 1/4 (47)	25 1/4 (64)	250 (63)	
LG325	26 3/4 (68)	8 (20)	18 7/8 (48)	26 1/2 (67)	325 (82)	
LG400	31 3/4 (81)	9 (23)	21 1/2 (55)	27 1/2 (70)	400 (101)	

* Ratings shown are for both natural and propane gas.

Figure 1. General Configuration.

The Lite2 LG heater may be installed indoors or outdoors as outlined in later sections. Location of the heater below *or above* the pool water level affects operation of its water pressure switch. See sections on water piping and heater start-up for more information about this.

Avoid placing the heater in locations where it can cause damage by water or condensate leakage. If this is not possible, provide a suitable drain pan to catch and divert any leakage. The pan must not block natural flow of air around the heater.

All criteria given in the following sections reflect minimum clearances as stated in the national standards. However, each installation must also be evaluated taking into account the prevailing local conditions

such as wind speed and direction, proximity and height of walls that may block ventilation or cause down drafts, and proximity to public access areas.

2.3.2 Clearances

The heater must be placed to provide clearances on all sides for maintenance and inspection. There must also be minimum distances maintained from combustible surfaces (see Table 2).

At least 20" (500mm) access must be available in front of the heater for burner removal.

If the heater is to be installed in a garage, or similar structure, all burners and burner ignition devices must have a minimum 18" (457mm) clearance above the floor.

Table 2. Minimum Heater Clearances From Combustible Surfaces
Table 2. Dégagements Minimaux à Assurer Entre les Parois de L'appareil et les Constructions Combustibles

SIDE OF HEATER	INDOOR (OUTDOOR SHELTER) INSTALLATION		OUTDOOR INSTALLATION	
	INCHES	CENTIMETERS	INCHES	CENTIMETERS
BLANK*	6	15	6	15
REAR	6	15	6	15
PIPING	12	30	12	30
TOP	44	112	OPEN UNROOFED AREA	
FRONT	ALCOVE**	ALCOVE**	OPEN	OPEN

Note: Clearances listed in Table 2 are manufacturer's tested values. These are given as minimum values. Where local and national codes apply, and values are different than those listed in Table 2, use the greater value to ensure safe operation.

- * Refers to side opposite piping
- ** A closet with no door
(In US-18 in (46 cm) clearance;
In Canada-24 in (61 cm) clearance)

2.3.3 Flooring

The heater shall be installed on a **level** floor of noncombustible construction or on fire-resistant slabs or arches. Noncombustible flooring is defined as flooring material and surface finish not capable of being ignited and burning and with no combustible materials against the underside. Acceptable materials are those consisting entirely of a combination of steel, iron, brick, tile, concrete, slate, glass or plaster. **Do not** install the heater directly on a combustible wood or carpet floor without placing a noncombustible platform between the floor and the heater.

The heater can be installed on a combustible floor if a noncombustible base assembly, available from Jandy, is used. See the heater rating plate or the Parts List (Section 11) of this manual for the appropriate base part number. **Heaters must never be installed directly on carpeting.**

As an alternative to the Jandy noncombustible base plate, in the United States, the National Fuel Gas Code allows a heater to be placed on a combustible surface when there is a platform under the heater made of hollow masonry no less than 4 inches (102 millimeters [mm]) thick, covered with sheet metal at least 24 gauge thick and extending beyond the full width and depth of the heater by at least 6 inches (152 mm) in all directions. The masonry must be laid with ends unsealed, and joints matched to provide free circulation of air from side to side through the masonry (see Figure 2). If the heater is installed in a carpeted alcove, the entire floor of the alcove must be covered by a noncombustible panel.

2.3.4. Outdoor Installation

Lite2 heaters can be installed in the low-profile top configuration as received from the factory, or with an optional high wind vent cap.

Locate the heater in an **open, unroofed area**. Do not install the heater under a deck.

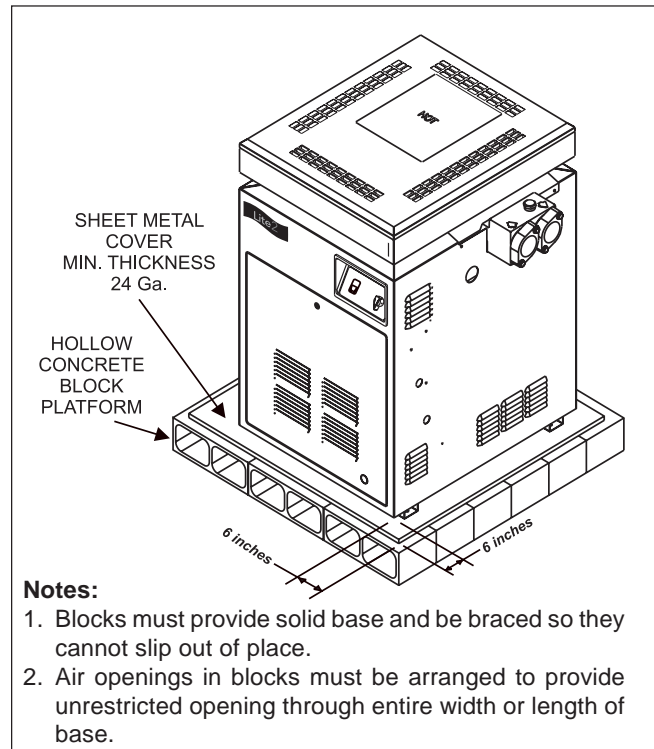

Figure 2. Non-Combustible Platform.

Do not locate the heater below or adjacent to any doors, glass openings, louvers, grills, etc., which connect in any way with an inhabited area of a building, even though the access might be through another structure (e.g., a garage or utility room). In the United States there must be a minimum of four (4) feet (1.22 m) horizontally **or** four (4) feet (1.22 m) vertically between the heater exhaust point and any door, glass opening, or gravity inlet to a building. In Canada, the heater must be installed so that the exhaust point of the heater is at least ten (10) feet (3.0 m) from any building opening (see Figure 3).

⚠ WARNING
United States

Do not install the heater with the top of the vent assembly within 4 feet (1.22 m) horizontally and 4 feet (1.22 m) vertically of any opening into a building.

Canada

Do not install the heater with the top of the vent assembly within 10 feet (3.05 m) of any opening into a building.

⚠ AVERTISSEMENT

Lorsque vous installez l'appareil de chauffage, assurez-vous que l'ouverture d'aération se trouve à un minimum de 10 pieds (3,05 m) de toute ouverture d'un bâtiment.

The top surface of the heater must be at least three(3) feet above any forced air inlet, or intake ducts located within ten(10) feet horizontally.

If the heater is installed under an overhang, there must be a minimum clearance of 5 feet (1.5 m) above the top of the heater and the structure should not overhang the heater more than 12 inches (0.30 m). The area under the overhang must be open on three sides. This prevents combustion gases from being diverted into living areas through doors, windows, or gravity inlets.

Ne pas installer ce chauffe-piscine sous une saillie mesurant moins de 5 pi de hauteur. La partie sous la saillie doit être ouverte sur 3 côtés.

If the heater is installed close to a structure, protect it from rain water runoff with rain gutters on the roof or other measures. Do not locate the heater near irrigation sprinkler systems that could spray water on it. Water from sprinklers may cause damage to controls and electronic components.

Avoid locations where wind deflection off nearby structures might cause downdraft conditions. Where downdraft conditions exist, locate the heater at least 3 feet (0.91 m) from vertical surfaces (e.g., nearby buildings and walls). The addition of a vent cap may be necessary.

In Florida it is required that the heater be securely fastened to the equipment pad. Use a size 1/4" x 1-1/2" long stainless steel Tapcon® type concrete screws and washers at each of the four tabs located at the base of the heater. Mounting the appliance in this manner meets the applicable requirements of the Florida Building Code.

Mounting screws are not provided with this heater. After placing the heater on the equipment pad, drill a hole in the concrete at each of the four tabs on the feet of the heater. (The correct size drill bit is usually provided with the concrete screws when purchased). Place a screw in each of the holes and fasten the heater to the equipment pad (see Figure 4). **Do not over torque the screws.**

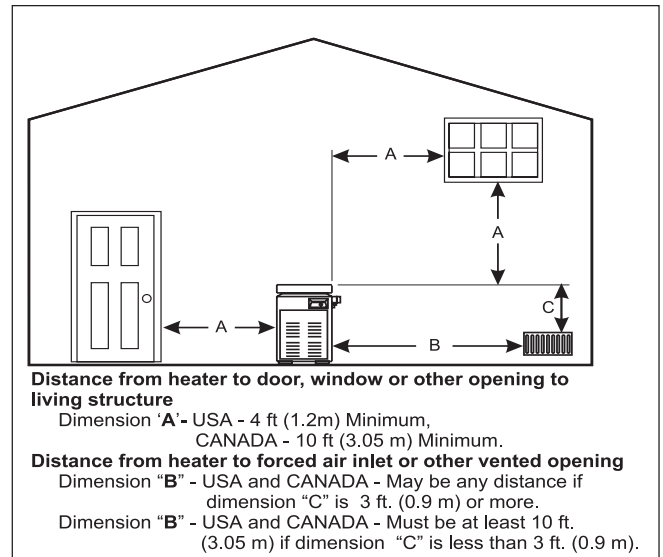

Figure 3. Outdoor Heater Installation.

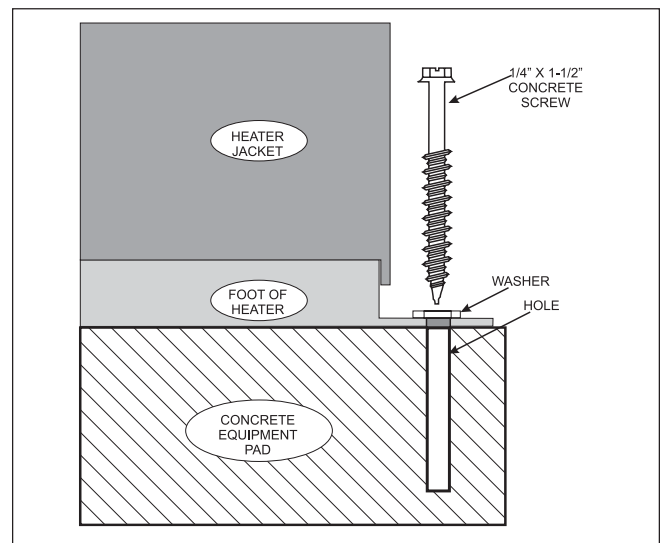

Figure 4. Anchor Heater To Equipment Pad

2.3.5. Indoor and Outdoor Shelter Installations

An outdoor shelter (Canada only) is an unoccupied enclosure which does not communicate directly with occupied areas. All indoor installations and outdoor shelter installations require the addition of a factory approved draft hood. The draft hood must be installed without modification and in accordance with all local, state, provincial and national codes.

Une remise extérieure (au Canada seulement) est un endroit inoccupé qui ne communique pas directement avec les endroits occupés. Toutes les installations intérieures et remises extérieures exigent l'addition d'une coupe-tirage intérieur approuvée par le manufacturier. La coupe-tirage intérieur doit être installée sans aucune modification et selon les exigences fournies par le manufacturier.

These codes, standards and Water Pik Technologies require that the heater be properly vented as outlined in this manual. Proper ventilation of exhaust and combustion air are essential for the safe and

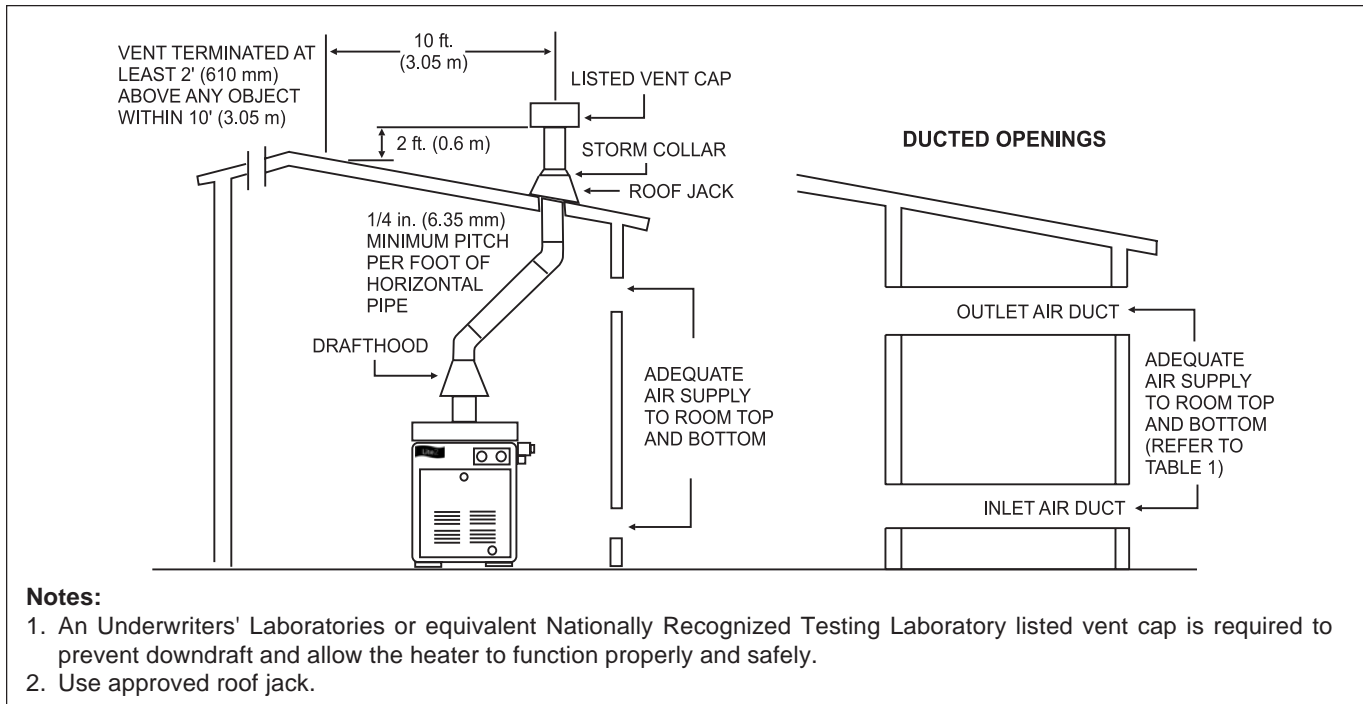

Figure 5. Indoor Installation Venting (USA), or Outdoor Shelter (Canada).

Table 3. Air Openings to Outside.

Model	Required Net Free Open Area* for Combustion Air Openings		Direct from outside		Duct from outside	
	in ²	(cm ²)	in ²	(cm ²)	in ²	(cm ²)
125	32	(206)	64	(413)		
175	44	(284)	88	(568)		
250	63	(406)	126	(813)		
325	82	(429)	164	(1058)		
400	100	(645)	200	(1290)		

*Area indicated is for one of two openings; one at floor level and one at the ceiling, so the total net free area would be double the figures indicated. For special conditions, refer to NFPA54/ANSI Z223.1. **In Canada refer to the National Standard CAN/CSA-B149.1 which differs from this table.**

Note: If using screens and/or metal louvers, compensate by adding 50% additional area to each opening

If using wood louvers each opening must be at least four times the area indicated in the table above.

efficient operation of the heater (See Section 3). An approved draft hood may be purchased from your local Jandy distributor. See Section 11 (Parts List) of this manual for the correct part number for you model and size heater.

SECTION 3. Venting

3.1. Combustion Air Supply

The heater location must provide sufficient air supply for proper combustion and ventilation of the surrounding area as outlined in the latest edition of ANSI standard Z223.1 or in Canada, CAN/CSA-B149.1, and any local codes that may be applicable.

In general, these requirements specify that the room in which a heater is installed should be provided with two permanent air supply openings; one within 12 inches (305mm) of the ceiling, the other within 12 inches (305mm) of the floor. All indoor installations must have openings to outside air for combustion, ventilation, and dilution of flue gases from inside the building (see Figure 5 and Table 3). Water Pik Technologies does not recommend indoor installations that do not provide combustion air from outside the building.

All outdoor shelter installations (Canada only) must have uninterrupted openings to outside air for combustion and ventilation. The installation must be in accordance with the latest edition of CAN/CSA-B149.1. Water Pik Technologies does not recommend outdoor shelter installations that depend on internal air for combustion. Combustion air should be ducted to the heater from outside the structure.

Outside Air Supply: When combustion air is supplied directly through an outside wall, each opening should have a minimum free area of one square inch per 4,000 BTU/h (1.2kW) input of the total input rating of all appliances in the enclosed area. If air is provided through horizontal ducts, each opening and duct must provide one square inch of flow area for each 2000 BTU/h (0.6 kW). These requirements are summarized in Table 3. Note that the areas specified are net free areas and should be increased by 50 percent when the openings are covered by screens, louvers, grills or other protective covers (see Figure 5 and Table 3).

Note: In Canada, follow Canadian Standard, CAN/CSA-B149.1 or local codes.

Exhaust Fans or Vents: Any equipment which

exhausts air from the room where the heater is installed can deplete the combustion air supply or reverse the natural draft action of the venting system. This could cause flue products to accumulate in the room. Additional air must be supplied to compensate for such exhaust.

The information in Table 3 is not applicable in installations where exhaust fans or blowers of any type are used. Such installations must be designed by qualified engineers.

If a blower or fan is used to supply air to the room, the installer should make sure it does not create drafts which could cause nuisance shutdowns of the pilot.

The heater must be completely isolated and protected from any source of corrosive chemical fumes such as those emitted by trichlorethylene, perchloroethylene, chlorine, etc.

⚠ WARNING

Do not store any chemicals, cleaners, or other corrosive material near combustion air openings or in the room. Avoid locating dryer vents in the vicinity of combustion air openings. Failure to prevent corrosive materials from mixing with combustion air can result in reduced heater life and unsafe heater operation.

⚠ AVERTISSEMENT

N'entreposer aucun produit chimique, produit nettoyant ou produit corrosif à proximité des bouches d'air de combustion ou dans la pièce. Éviter de placer des tuyaux de ventilation pour sècheuse à proximité des bouches d'air de combustion. Le fait de laisser des matières corrosives se mélanger à l'air de combustion risque de réduire le cycle de vie de l'appareil de chauffage et de compromettre son fonctionnement.

3.2 Vent Pipe Sizing and General Installation

3.2.1. Outdoor Installations

For outdoor installations, exhaust venting considerations will determine the placement of the heater (See Section 2.3.4). If the heater cannot be placed so as to meet the requirements stated in Section 2.3.4, a vent pipe and cap may be added to the heater to move the exhaust vent opening to a position that complies with the requirements. When the heater is installed in areas of high wind or when unavoidably installed near a vertical obstruction where downdrafting may occur, it may be desirable to add a vent cap directly to the top of the heater. In all cases, vent pipes and caps must be of the same diameter as the exhaust outlet of the heater. Approved vent caps may be obtained through your Jandy distributor.

3.2.2. Indoor and Outdoor Shelter Installations

⚠ WARNING

Vent pipe diameter must be as required by the National Fuel Gas Code ANSI Z223.1 or the Canadian Installation Codes for Gas Appliances CAN/CSA-B149.1. Undersize pipe can result in inadequate venting and oversize pipe can result in vent condensation. In either case the result can be release of combustion products to the indoors. This can cause serious injury or death by carbon monoxide poisoning or asphyxiation.

⚠ AVERTISSEMENT

Le diamètre des tuyaux de ventilation doit répondre aux exigences du *National Fuel Gas Code* ANSI Z223.1 ou du code canadien des installations des appareils à gaz CAN/CSA-B149.1. Des tuyaux trop petits risquent d'entraîner une ventilation inadéquate et des tuyaux trop gros risquent de provoquer une condensation dans les tuyaux. Dans un cas comme dans l'autre, des produits de combustion risquent de s'échapper dans le bâtiment et causer des blessures graves ou l'asphyxie par le monoxyde de carbone.

All indoor installations and outdoor shelter installations require the addition of a factory approved draft hood. The draft hood must be installed without modification.

All vent installations must be made in accordance with all local, state or provincial codes and with:

1. Chapter covering "Venting of Equipment" of the national Fuel Gas Code, ANSI 223.1 latest edition, or the applicable provisions of the local building codes.
2. In Canada, CAN/CSA-B149.1.

Avoid long horizontal runs of the vent pipe, and 90° elbows, reductions and restrictions. Horizontal runs should have at least a 1/4 inch rise per foot (20mm per meter) in the direction of flow.

Avoid terminating heater vents near air conditioning or air supply fans. The fans can pick up exhaust flue products from the heater and return them inside the building, creating a possible health hazard.

Do not locate the vent terminal where flue products could strike against building materials and cause degradation.

Vent opening should be well away from trees or other obstructions that would prevent free air flow to and from vent terminal. Do not terminate the vent under decks, stairways, or car ports.

Be sure to support all venting so that connections

will not separate and so that the weight of the vent pipe does not rest on the heater draft hood. All connections should be made with rustproof sheet metal screws. Do not weld or fasten the vent pipe to the heater draft hood. The draft hood and heater top must be easily removable for normal heater service and inspection.

The draft hood outlet is to be connected to an unobstructed vent pipe of the same diameter, terminating outside the building. The vent must terminate at least two (2) feet (0.61 m) above the highest point of the roof or other object that is within ten (10) feet (3.05 m) of the vent termination. The vent pipe must have a listed vent cap which allows a full equivalent opening for flue products (see Figure 5). The top of the vent cap must be at least five feet in vertical height above the draft hood outlet.

Type “B” double wall or equivalent vent pipe is recommended. However, single wall metal vent pipe may be used as specified in the latest edition of the National Fuel Gas Code ANSI Z223.1 or in Canada CAN/CSA-B149.1

IMPORTANT NOTE: Do not use sheet metal screws at the snap lock joints of Type B gas vents.

When venting multiple appliances through one common duct, each appliance must have its own vent temperature limit switch. All vent limit switches must be wired in series so as to prevent any appliance from firing in the event of a blocked vent. Refer to ANSI Z223.1 or, in Canada, to CAN/CSA-B149.1 for more information on multiple venting.

3.2.3 Inspection and Replacement of Existing Vent System with New Components

If the Lite2 is being installed to replace an existing pool heater, it is recommended that a new appropriate venting system be installed with the new heater. However, if an existing venting system must be used, be sure to carefully inspect the venting system to ensure that it is in good condition and continues to be appropriate for the Lite2 heater. Replace any parts that are not in good and serviceable condition with new parts before completing the pool heater installation.

SECTION 4. Gas Connections

4.1 Gas Supply and Piping

Review the following general instructions before continuing the installation.

WARNING

The Lite2 pool and spa heaters are designed for use with either natural gas or LP gas. Check the rating plate on the inner panel to be sure that the heater is configured to use the type of gas being supplied. **DO NOT ATTEMPT TO CONVERT THIS HEATER FOR USE WITH ANY OTHER TYPE OF FUEL.**

AVERTISSEMENT

Les appareils de chauffage à Lite 2 pour piscines et cuves thermales sont conçus pour être utilisés avec du gaz naturel ou du gaz de pétrole liquéfié (GPL). Vérifiez l'information inscrite sur la plaque signalétique du panneau intérieur pour vous assurer que l'appareil est configuré pour le type de gaz fourni. **NE PAS ESSAYER DE CONVERTIR CET APPAREIL À UN AUTRE TYPE DE GAZ.**

1. Gas piping installation must be in accordance with the latest edition of ANSI Z223.1 and all local codes. In Canada, the installation must be in accordance with CAN/CSA-B149.1 and all local codes that apply.
2. Check the gas supply to be sure that it is the same as the gas indicated on the heater's rating plate. Lite2 LG heaters, as shipped from the factory, are certified to operate within the altitude range indicated on the rating plate. If a field conversion to a different altitude range should be necessary, manifold kits are available for changing the altitude range of the heater. See Table 1 in section 1.7.1 of this manual to determine the correct altitude designation for your heater. Refer to Section 11 “Parts List” to order the correct part number of the manifold kit needed. When changing the altitude range of the heater, be sure to fill out the altitude conversion label, included in the kit. Apply the label on the inner panel of the heater, next to the original rating plate.

CAUTION

Permanent damage to the gas valve will occur if the following procedures are not followed.

ATTENTION

Vous endommagerez la soupape de gaz si vous ne respectez pas les procédures suivantes.

3. Use the figures in Table 4 to size the gas inlet piping from the gas meter to the heater. Check all local codes for compliance before installing the heater.

Table 4. Natural Gas Pipe Size Requirements*

Heater Size	Distance from Gas Meter					
	0-50 feet (0-15 m)		50-100 feet (15-30 m)		100-200 feet (30-60 m)	
	in.	(mm)	in.	(mm)	in.	(mm)
125	3/4	(19)	1	(25)	1	(25)
175	1	(25)	1	(25)	1-1/4	(32)
250	1	(25)	1-1/4	(32)	1-1/4	(32)
325	1-1/4	(32)	1-1/4	(32)	1-1/2	(38)
400	1-1/4	(32)	1-1/2	(38)	1-1/2	(38)

Notes:

- *1. These numbers are for natural gas (0.65 Sp. Gr.) and are based on 1/2 inch (13mm) water column pressure drop. Check supply pressure with a manometer, and local code requirements for variations. For liquefied petroleum gas, reduce pipe diameter one size, but maintain a 3/4 inch (19mm) minimum diameter.
- 2. Check supply pressure and local code requirements before proceeding with work.
- 3. Pipe fittings must be considered when determining gas pipe sizing.

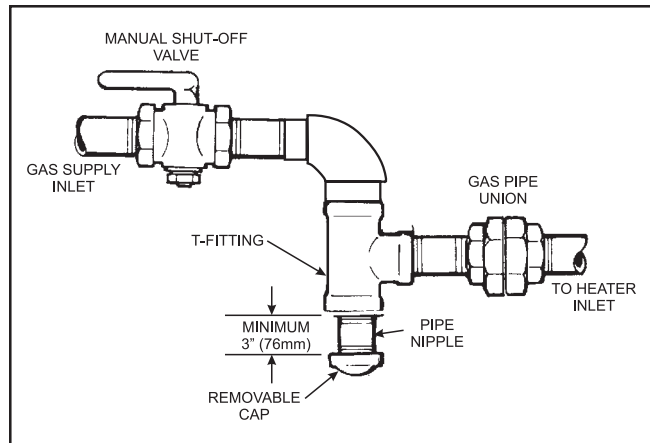

Figure 6. The proper design for a sediment trap/drip leg.

4. Install a sediment trap (drip leg) ahead of the gas controls (see Figure 6). Fit the trap with a threaded cap which can be removed for cleaning.
5. Install a manual gas shutoff valve for service and safety. Do not use a restrictive gas cock. **DO NOT USE FLEXIBLE GAS PIPING**, it will restrict the gas flow to the heater.
6. Disconnect the heater and its individual shutoff valve from the gas supply system during pressure testing of the system at pressures higher than 1/2 pounds per square inch (psi) (3.45 kilopascals [kPa]). If the test pressure is equal to or less than 1/2 psi (3.45 kPa), close the manual shutoff valve on the heater during the piping pressure test.
7. If the gas supply pressure is less than required, check for undersized pipe between the meter and the heater, a restrictive fitting, or an undersized gas meter. Gas supply pressures to the heater are listed in Table 5.

NOTE: The maximum inlet gas pressure must not exceed the specified value. The minimum value listed is for the purpose of input adjustment. Refer to Table 5.

Table 5. Gas Supply Pressure Requirements

Supply Pressure	Minimum	Maximum
Natural Gas	5.5 Inches WC (1.4 kPa)	10.0 Inches WC (2.5 kPa)
LP Gas	10.0 Inches WC (2.5 kPa)	14.0 Inches WC (3.5 kPa)
Manifold Pressure	Nominal	
Natural Gas	4.0 Inches WC (1.0 kPa)	
LP Gas	9.0 Inches WC (2.2 kPa)	

8. Before operating the heater, test the complete gas supply system and all connections for leaks using a soap solution. Do not use an open flame.

CAUTION

Some leak test solutions (including soap and water) may cause corrosion or stress cracking. Rinse the piping with water after testing.

ATTENTION

Certaines solutions d'essai d'étanchéité (y compris l'eau et le savon) peuvent causer de la corrosion ou de la fissuration. Rincez les tuyaux à l'eau après l'essai d'étanchéité.

4.2 Manifold Pressure

Confirm that gas supply pressure is correct. If the gas supply pressure is less than required, check for undersized pipe between the meter and the heater, a restrictive fitting, or an undersized gas meter. Gas supply pressures to the heater, when it is operating, are listed in Table 5.

CAUTION

Manifold gas pressure for the Lite2 Lg natural gas heaters should be set at 4" WC. Propane heaters should be set to 9" WC.

ATTENTION

La pression du collecteur de pression pour les systèmes de chauffage au gaz naturel devrait être de 4" WC. Pour les systèmes de chauffage au gaz propane devrait être de 9" WC.

The manifold pressure may be checked by connecting a manometer to the pressure port on the outlet side of the valve. You will need to remove the 1/8"

NPT protective plug from the port and install the appropriate 1/8" NPT fitting to connect your manometer. The pressure will be zero when the heater is not running. When the heater is operating the manifold gas pressure should be 4.0" WC for natural gas heaters and 9.0" WC for LP gas heaters.

To adjust the manifold gas pressure, first remove the slotted cap on the top of the gas valve to the right of the control knob. Under the slotted cap is a slotted plastic screw which increases the manifold pressure when turned clockwise and decreases the manifold pressure when turned counterclockwise.

After measurements, and adjustments if necessary, have been made, make sure to replace the 1/8" NPT plug on the manifold pressure ports, and the cap on the manifold pressure adjustment screw. It is extremely important to replace these parts before leaving the installation. Failure to do so can result in damage to property or injury or death.

With the heater firing, the pressure must be within the range shown in Table 5. Also check the pressure with the heater off.

4.3 Special Precautions for LP Gas

LP Gas is heavier than air and can therefore more readily collect or "pool" in enclosed areas if provision for proper ventilation is not made. Installation of pool heaters in enclosed areas such as pits is not recommended. However, if such an installation is required be sure to pay special attention to proper ventilation for LP gas. Locate heaters a safe distance from LP gas cylinders and filling equipment. In the United States, consult the "National Fuel Gas Code" (NFPA 54 / ANSI Z223.1, latest edition) or in Canada,

the "Natural Gas and Propane Installation Code" (CAN/CSA-B149.1), and any local codes and fire protection authorities about specific installation restrictions in your area.

SECTION 5. Water Connections

5.1 Water Piping

Figure 7 illustrates typical piping for pool equipment in pool/spa combination pools.

For normal installations, do not install a shutoff valve or any kind of variable restriction in the water piping between the heater outlet and the pool/spa. In special installations where a shut-off valve, diverter valve or other variable restriction is required in the plumbing between the heater outlet and the pool, Water Pik Technologies recommends the installation of a pressure relief valve on the heater (see Section 5.6).

Arrangement of pool system components other than as illustrated in these diagrams can affect the operation of the heater's water pressure switch. Location of the heater above or below the pool water surface can also affect operation of the switch. In general, the pressure switch can be adjusted to accommodate this effect if the heater water connections are no more than six feet below the pool water surface and no more than 15 feet above it. See instructions for pressure switch adjustment (Section 7.5) in the heater start-up section of this manual for more information about this.

Note that when pool equipment is located below

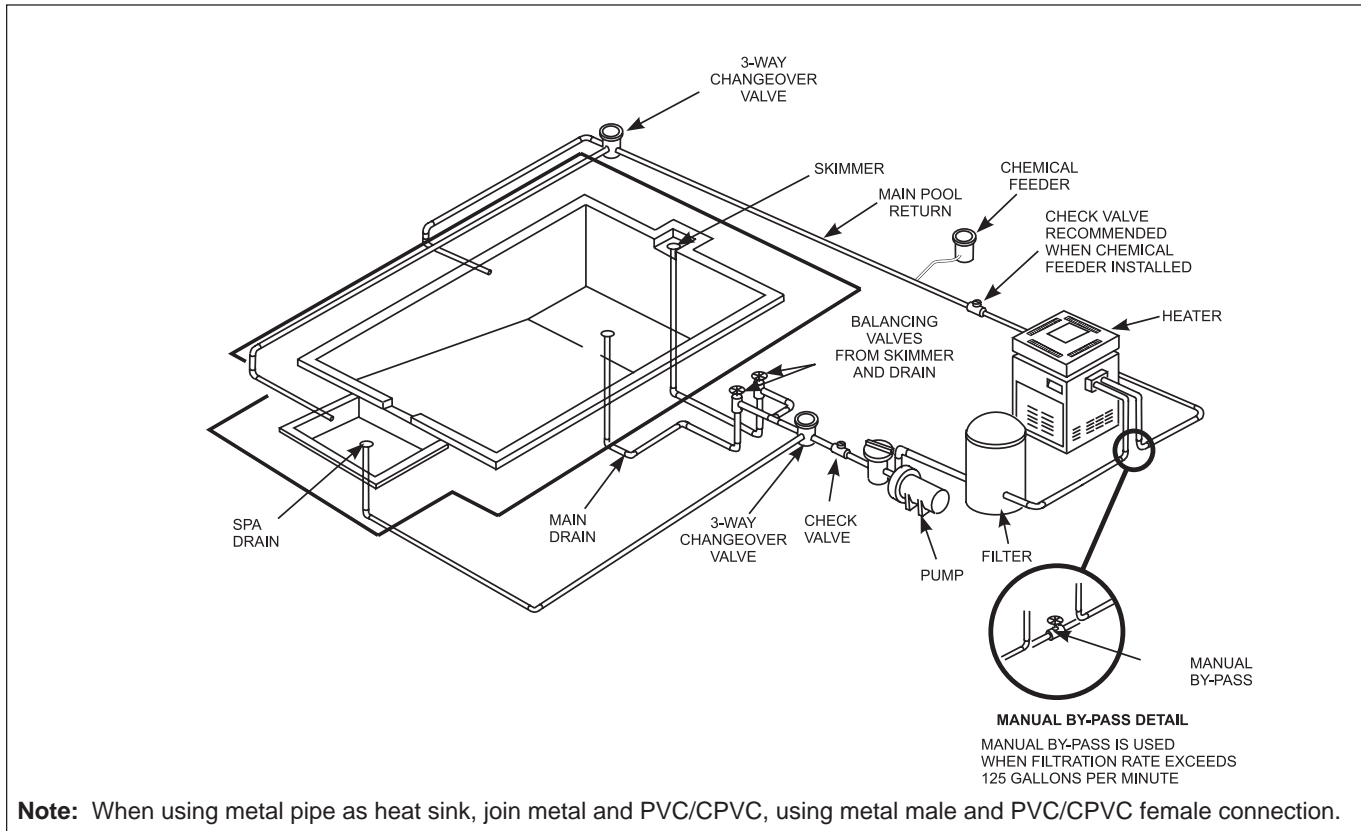

Figure 7. Typical installation.

the pool surface a leak can result in large scale water loss or flooding. Water Pik Technologies cannot be responsible for such water loss or flooding or the damage caused by it.

For special installations such as water connections below the water level of the pool, or for other questions contact the Jandy Technical Service department at (707)-776-8200 ext 260.

5.2 Check Valve Installation

The heater must be protected from back-siphoning of water, which can result in dry starts. If there is any chance of back-siphoning, provide a check valve between the pool and the filter pump inlet.

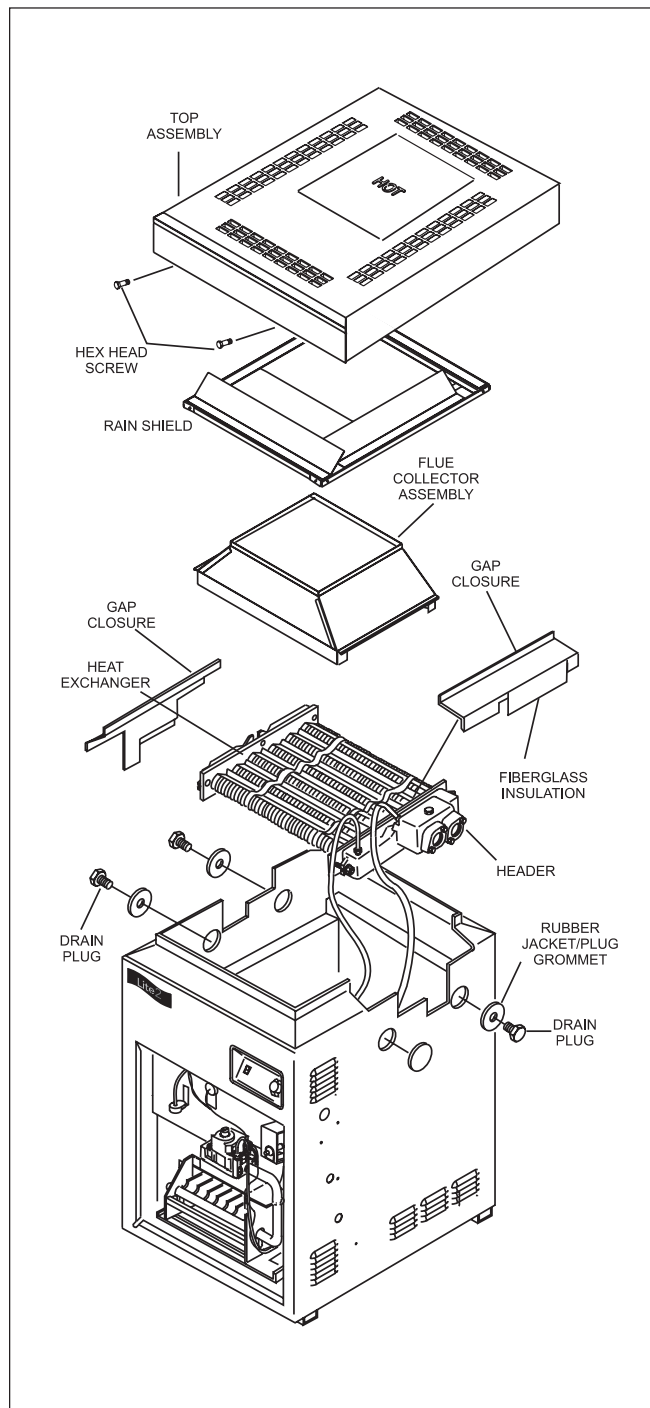

Figure 8. Heat exchanger reversal.

When an automatic chemical feeder is installed in the plumbing, it must be installed downstream of the heater (see Section 5.7). A check valve must be installed between the heater and the chemical feeder to prevent back-siphoning of chemically saturated water into the heater where it will damage the components.

5.3 Automatic Flow Control Valve

The inlet/outlet header of the Lite2 comes equipped with an automatic flow control valve. The automatic flow control valve maintains the proper flow through the heater at rates up to approximately 125 Gallons Per Minute (GPM) (474 liters per minute [LPM]). If the filter system flow rate is higher than approximately 125 GPM (474 LPM), install a manual bypass valve (see Figure 7), then perform a temperature rise test (see Section 7.6) and adjust the flow using the bypass valve until the proper temperature rise is obtained.

5.4 Reversible Water Connections

Water Pik Technologies ships the Lite2 heater with the water connections on the right side. The Lite2 heater can be installed with the water connections on either side. It could be necessary, or helpful, to switch the connections to the left side to improve access for installation and service. Perform this modification before installing the heater using the following procedures:

1. Remove heater door.
2. Remove all 8 hex-head screws fastening the top and lift the top assembly straight up (see Figure 8).
3. Remove rainshield assembly and set it aside.
4. Remove screws that fasten the gap closures to the jacket and put them aside. Remove gap closures.

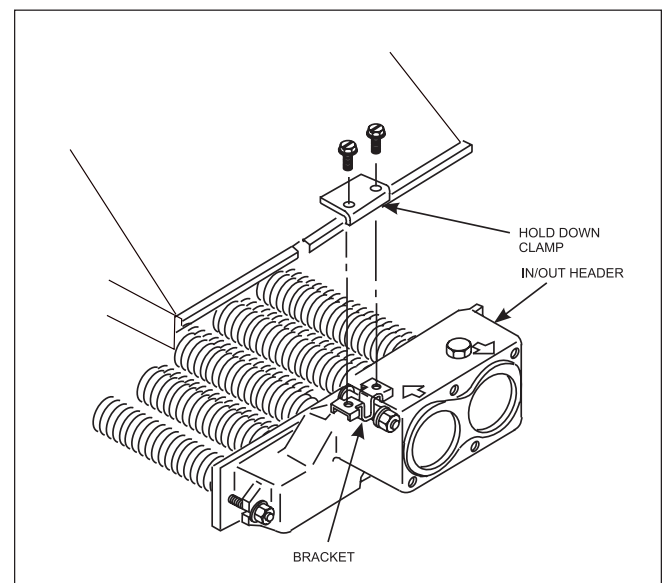

Figure 9. Flue collector hold-down brackets.

5. Remove the screws securing the two flue collector hold down clamps and remove the clamps (see Figure 9). Remove flue collector.
6. Remove the three rubber jacket/plug grommets and drain plugs (see Figure 8). One is located under the water connections on the right side. The other two are on the left side of the heater.
7. Tag and disconnect the white wire on the pressure switch (PS) and the white wire on the Fireman's switch terminal which leads to the high limit switch.
8. Remove plastic tie wraps and pull the white wires out of the front compartment through the vestibule cover and coil them on the heat exchanger.
9. Unscrew the brass compression fitting securing the pressure switch to the inlet/outlet header. Remove tube from header and gently bend it out of the way.
10. Loosen the screw securing the temperature sensing bulb retainer bracket. Slide the retainer bracket off the bulb flange and remove the bulb from the header (see Figure 10). Pull pressure switch tube through the hole in the vestibule cover and into the vestibule (controls compartment), then pull thermostat bulb assembly through same hole (see Figure 11).
11. When removing the heat exchanger from the heater, the end baffles of the heat exchanger (installed only on sizes 125 BTU, 175 BTU and 250 BTU) must be removed. There are two baffles covering part of the front and rear tubes of the heat exchanger. Each baffle is held in place by two screws which mount to the top of the combustion chamber wall. Remove the screws and the baffles before attempting to lift the heat exchanger out of the heater (see Figure 12).

⚠ CAUTION

It may be necessary to have help lifting the heat exchanger out and replacing it.

⚠ ATTENTION

Il peut être nécessaire d'avoir besoin d'aide pour enlever et remplacer l'échangeur de chaleur.

12. Lift the heat exchanger assembly out of the heater. Reinstall heat exchanger 180 degrees (inlet/outlet header left) from it's original position.

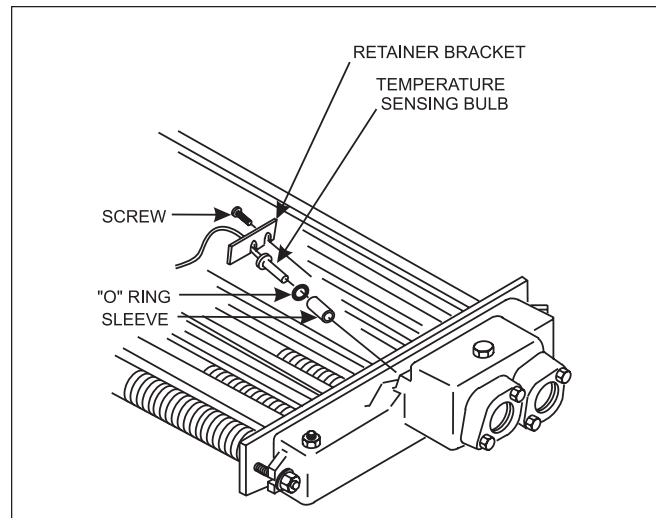

Figure 10. Temperature sensing bulb.

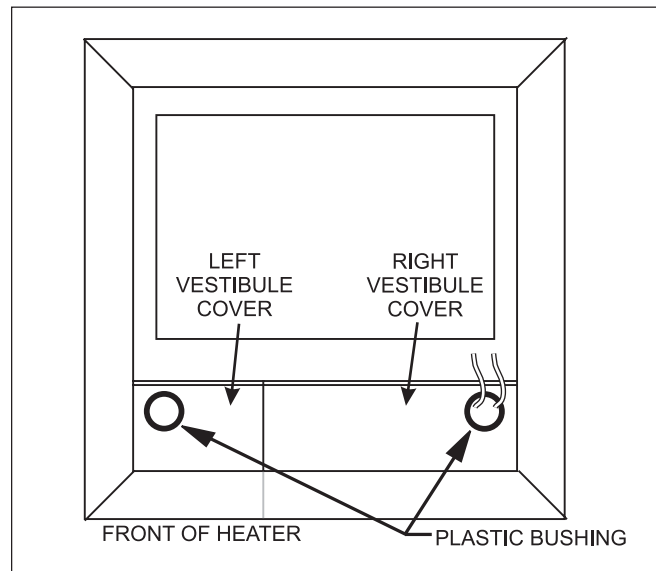

Figure 11. Vestibule covers.

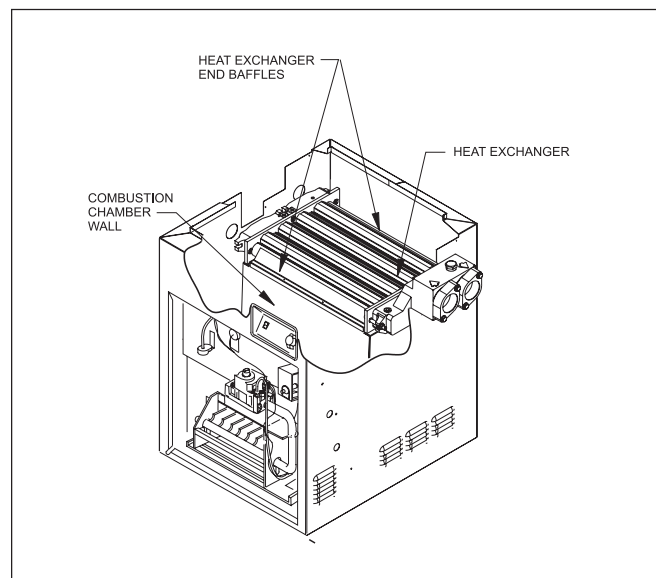

Figure 12. Heat exchanger and end baffles.

13. After replacing the heat exchanger into the heater, the end baffles must be replaced. Each one is held in place by two screws which mount to the top of the combustion chamber wall. Reinstall the baffles on the front and rear of the heat exchanger before continuing with the "Reversible Water Connections" procedure.
14. Remove pressure switch retainer (plastic cable clamp) from the inner panel (allow pressure switch to float).
15. Reroute the pressure switch tube and thermostat bulb assembly through hole in left side of vestibule cover in reverse order.
16. Reinstall the temperature sensing bulb in the header, and fasten it with the retainer bracket and screw.
17. Reinstall the compression fitting at the end of the pressure switch tube into inlet/outlet header and tighten the fitting.
18. Route the white wiring from the high limit switches beside the heat exchanger and down to the original location following the pressure switch tubing. Secure white wires to the pressure switch tube with plastic wire ties.
19. Connect the white wire labeled PS to the pressure switch and the other white wire to its original location on the Fireman's switch.
20. Reinstall the drain plugs and tighten securely. Replace jacket/plug grommets.
21. Install the flue collector assembly. Be sure the front and rear panels of the flue collector are installed into the grooves on the front and rear combustion chamber heat shield panels. Be sure the sheet metal panels are not pinching any wires.
22. Attach the flue collector hold down clamps to the clips located under the two center header bolts.
23. Replace the gap closures and tighten the screws securely.
24. Double-check to make sure the wiring is not pinched against sharp edges, or resting on the flue collector assembly.
25. Reinstall rainshield assembly.
26. Replace the top assembly. Make sure the tabs are outside the heater jacket. Fasten the top assembly with the hex-head screws.

27. Install plastic tie wraps on wiring in the vestibule (controls compartment).
28. Install heater door.

5.5 Connections at Heater

The heater has 2" NPT universal header couplings. You can connect threaded 2" NPT iron pipe, unthreaded 1 1/2" iron or copper pipe or unthreaded 2" copper pipe using the appropriate seals included with this heater (see Figure 13). However, by installing the appropriate pipe adapters, other sizes may be used.

Plastic piping (PVC Schedule 40) can be connected to the heater if local codes allow it, by using the CPVC nipples included with your heater.

To install plastic piping (see Figure 14):

1. Remove CPVC nipples from plastic bag.
2. Screw CPVC nipples into metal flange until tight, using Teflon™ tape on plastic threads.
3. Prepare the end of the pipe with the proper adapter, PVC/CPVC primer and glue. Follow the manufacturer's instructions provided with the primer and glue for preparation procedures and curing times.

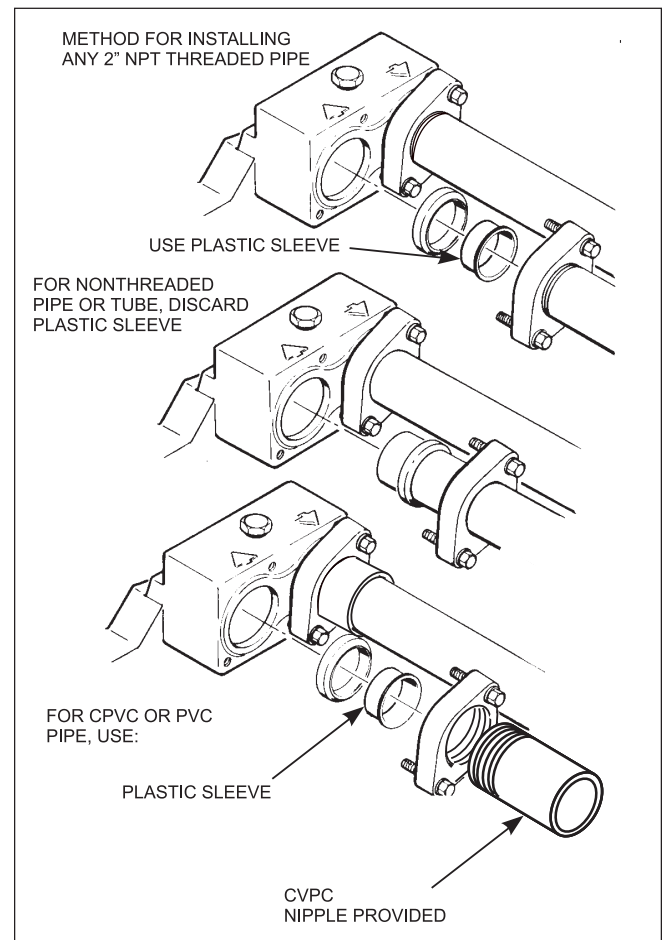

Figure 13. Piping installation.

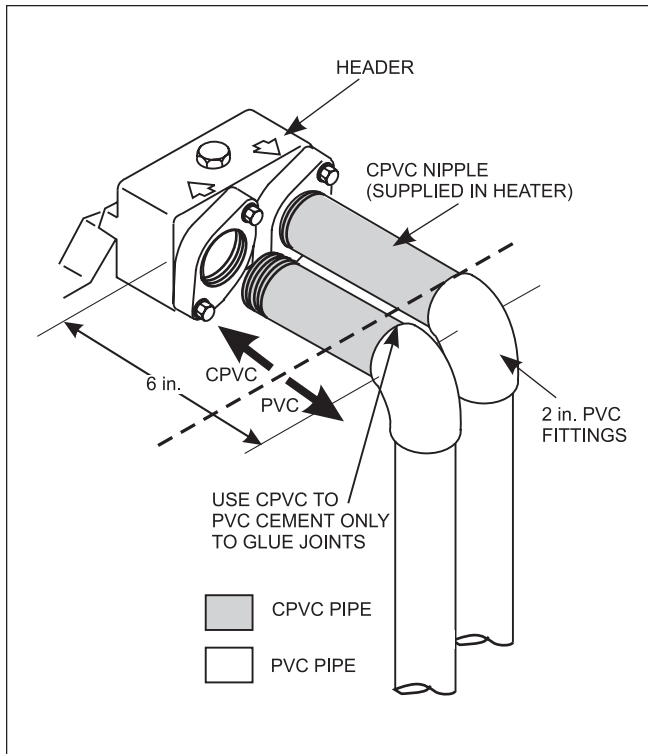

Figure 14. Plastic piping connections.

5.6 Pressure Relief Valve

A pressure relief valve (PRV) is recommended in all installations and is mandatory in any installation in which the water flow can be shut off between the heater outlet and the pool/spa.

A pressure relief valve is not supplied with the heater. However, it may be required by local codes. The pressure rating of the valve should be at or below the lowest working pressure of any component in the filter system. Any pressure relief valve installed must comply with provisions of the Standard described in ANSI Z21.22 for the United States, or CSA 4.4 in Canada.

To install a pressure relief valve, do the following:

1. Remove the 3/4 inch (19 mm) brass plug located on the top of the inlet/outlet header (see Figure 15).
2. Install the pressure relief valve in the threaded hole from which the plug was removed.
3. Be sure that the exhaust port of the PRV is plumbed so that any hot water is directed safely away from any public areas and away from any area occupied during servicing.

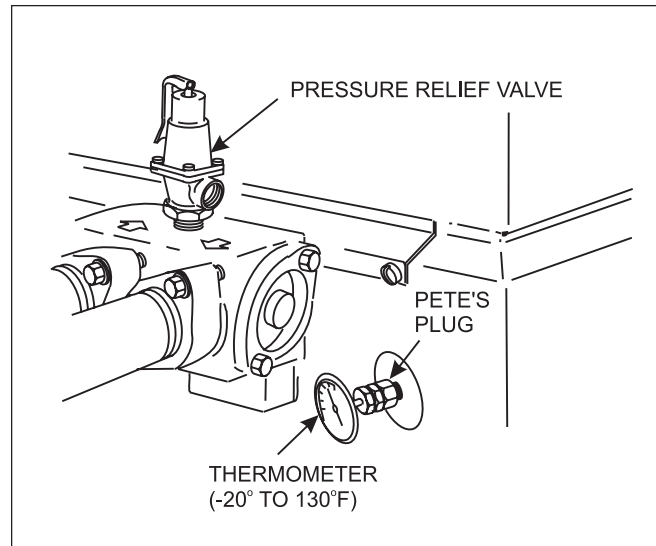

Figure 15. Thermometer and pressure relief valve.

5.7 Auxiliary Components, Chlorinators, Ozone Generators, and Sanitizing Chemicals.

The Lite2 heater is manufactured with materials that are not compatible with high concentrations of ozone, chlorine, bromine, or other sanitizing chemicals. Heater damage caused by excessive chemicals or improper ozonization is not covered by the Water Pik Technologies warranty. Be sure to adhere to the following:

- When ozone is injected upstream of the heater, install an offgas mixing chamber, or an ozone bypass system between the heater and the ozone injector to prevent ozone and air from entering the heater.
- When chemical feeders are used, plumb the feeder downstream of the heater and install an in-line check valve between the heater and the feeder (a minimum of 18" is required between the heater and the check valve).
- Never deposit chemicals directly in the pool skimmer.

SECTION 6. Electrical

WARNING

Label all wires prior to disconnection when servicing controls. Wiring errors can cause improper and dangerous operation. Verify proper operation after servicing.

AVERTISSEMENT

Au moment de l'entretien des commandes, étiquetez tous les fils avant de les débrancher. Des erreurs de câblage peuvent entraîner un fonctionnement inadéquat et dangereux.

6.1 Main Power

The Lite2 model LG heater does not require an external source of electrical power to operate. The power for the gas valve and safety circuit are generated by a thermopile. The thermopile generates a millivolt signal when heated by the pilot flame. Figure 17 shows the internal electrical wiring diagram and schematic of the heater.

6.2 Bonding

⚠ CAUTION

This heater must be connected to a bonding grid with a solid copper wire not smaller in diameter than 8 ga.

⚠ ATTENTION

L'appareil de chauffage doit être connecté à une grille de mise à la terre par un fil de cuivre d'un diamètre de calibre minimal 8.

The National Electrical Code and most other codes require that all metallic components of a pool structure, including reinforcing steel, metal fittings and above ground equipment be bonded together with a solid copper conductor not smaller than a number 8 wire. The heater, along with pumps and other such equipment must be connected to this bonding grid. A special labeled bonding lug is provided on the right side of the heater to accommodate this requirement.

6.3 Auxiliary Time Clock Wiring

If you install a time clock to control the filter pump operation, it is recommended that the time clock have its own low voltage (Fireman's) switch to turn off the heater before turning off the pump. The switch should shut off the heater about 15 minutes before the filter pump shuts off. This will allow for a more efficient operation by removing any residual heat contained in the heat exchanger back to the pool.

To install a time clock auxiliary switch into the heater wires (see Figure 16):

1. Remove heater door.
2. Remove the factory installed wire between terminals 1 and 2 on the terminal strip (see Figure 16).
3. Connect the wires from the time clock auxiliary switch to the two terminals. Use American Wire Gauge (AWG) No. 14 gauge stranded copper wire with a temperature rating of 221°F (105°C) or greater.

The length of the wire between the heater and the time clock should not exceed 10-15 feet (4.57 m). The contact points of the time clock switch should be silver, or a low resistance alloy.

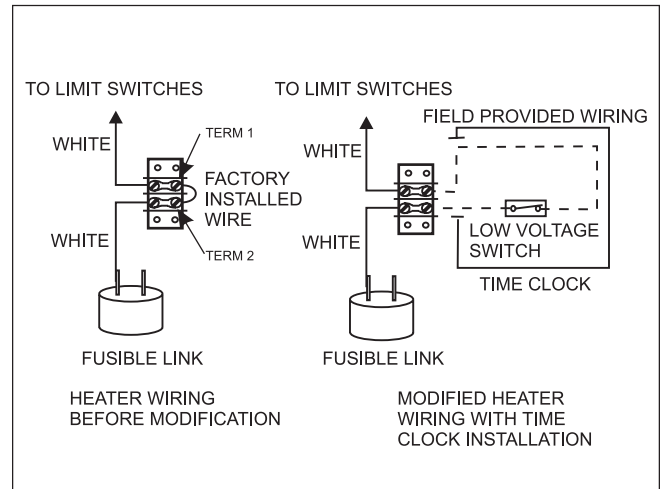

Figure 16. Time Clock Wiring.

SECTION 7. Operating Instructions

7.1 Normal Operation

The Lite2 model LG heaters are capable of automatic operation based on a call for heat at a preset temperature. The heater has an internal safety system which allows operation in a variety of conditions and prevents operation when certain adverse conditions are encountered.

When the heater's pilot is lit and the pilot generator is providing a millivolt signal to the safety circuit, water is flowing through the heater, and the temperature of the water entering the heater is below the temperature control setting, an operating cycle is initiated by the automatic control. The temperature control circuit is closed, activating the gas valve and the gas valve is opened. Gas flows through the burners, is mixed with air in the combustion chamber, and is ignited by the pilot. Operation will continue until the temperature of the water entering the heater reaches the temperature control setting.

If ignition is unsuccessful, or if the flame fails during normal operation, the temperature control circuit opens and shuts off the gas valve.

MILLIVOLT HEATER ELECTRICAL DIAGRAM

Schéma Électrique Du Chauffe-Eau Modèle Millivolt

Connection Diagram Schéma de montage

- BK - Black BK - Noir
- W - White W - Blanc
- Y - Yellow Y - Jaune
- R - Red R - Rouge

IF ANY OF THE ORIGINAL WIRE AS SUPPLIED WITH THE HEATER MUST BE REPLACED, APPLIANCE WIRING MATERIAL RATED FOR 105°C MUST BE USED. WHERE MARKED THUS **—** APPLIANCE WIRING MATERIAL FOR 200°C MUST BE USED.

Si l'un quelconque des fils d'origine fournis avec le chauffe-eau doit être remplacé, un fil pour appareils électriques à tolérance nominale de 105°C doit être employé. Si le fil porte le symbole, **—** le remplacer uniquement par un fil pour appareils électriques à tolérance nominale de 200°C.

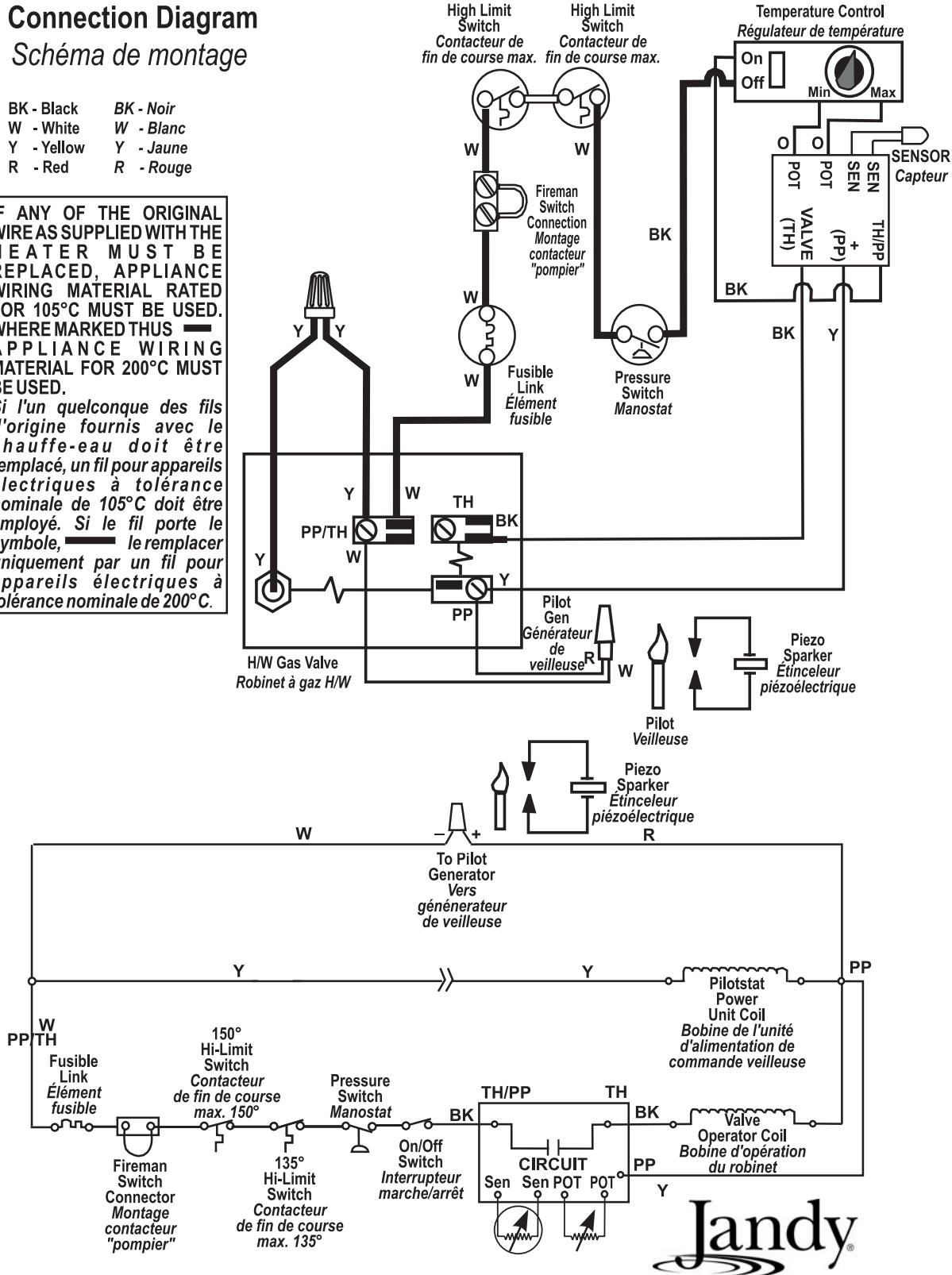

Figure 17. LG Connection/Schematic Wiring Diagram

7.2 Start-Up

CAUTION

Do not use this heater if any part has been under water. Immediately call a qualified service technician to inspect the heater and replace any part of the control system and any gas control which has been under water.

ATTENTION

N'utilisez pas cet appareil s'il a été plongé dans l'eau, même partiellement. Faites inspecter l'appareil par un technicien qualifié et remplacez toute partie du système de contrôle et toute commande qui ont été plongés dans l'eau.

CAUTION

Should overheating occur or the gas supply fail to shut off, turn off the manual gas control valve to the heater.

ATTENTION

En cas de surchauffe ou si l'alimentation en gaz ne s'arrête pas, fermez manuellement le robinet d'arrêt de l'admission de gaz.

CAUTION

Do not attempt repairs on the gas controls or appliance. Tampering is dangerous and voids all warranties.

ATTENTION

Ne tentez pas d'effectuer des réparations au système de régulation du débit du gaz ou à l'appareil. Toute modification non autorisée est dangereuse et entraîne l'annulation de toutes les garanties.

CAUTION

Keep all objects off the top of the heater. Blocking air flow could damage the heater, and may void the warranty.

ATTENTION

Ne posez aucun objet sur le dessus de l'appareil. Il pourrait empêcher la circulation de l'air, ce qui risquerait d'endommager l'appareil et d'annuler la garantie.

WARNING

Vent pipes, draft hoods, and heater tops get hot! These surfaces can cause serious burns. Do not touch these surfaces while the heater is in operation. Adding a vent cap reduces the temperature on the top.

AVERTISSEMENT

Les tuyaux d'aération et le dessus de l'appareil deviennent chauds! Ils peuvent causer de graves brûlures. Ne touchez pas à ces surfaces lorsque l'appareil est en marche.

WARNING

For your safety, when starting the heater, keep your head and face well away from the lower firebox opening to prevent any risk of personal injury.

AVERTISSEMENT

Pour votre sécurité personnelle lorsque vous mettez l'appareil en marche, tenez votre tête et votre visage loin du brûleur pour éviter tout risque de blessure.

Be sure that there is water in the pool and that the surface level is above the skimmer or other inlet of the pool's filter system.

Confirm that pool water is flowing normally through the pool system and equipment. With any new pool or spa installation, operate the filter pump with the heater off long enough to completely clean the water. This will remove any installation residue from the water. Clean the filter at the end of this operation before starting the heater. Start the heater in accordance with the Operating Instructions section of this manual, with particular attention to the lighting and shutdown instructions and temperature control operation.

When raising the temperature of a cold pool, remove all time clock settings. This lets the filter system and heater operate continuously until the water reaches the temperature setting on the temperature control. When that happens, the heater will automatically shut off, but the filter pump will keep running.

When the heater starts, immediately feel the outlet header of the heater to confirm that there is adequate water flow. The header should not be hot. Normally, water temperature will rise only a few degrees as it passes through the heater, and a "hot" header or pipe indicates low water flow.

⚠ WARNING

When the heater is fired for the first time, the combustion chamber refractory binder material is driven out by the heat of the flame. White smoke and/or sharp odors may be emitted from the vent during this period. Do not inhale combustion product fumes at any time, and especially when these fumes are being emitted. This "burn-in" period will last only a few minutes.

⚠ AVERTISSEMENT

Lorsque l'appareil est mis en marche pour la première fois, le matériau liant réfractaire de la chambre de combustion est expulsé par la chaleur de la flamme. De la fumée blanche et de fortes odeurs peuvent se dégager du tuyau d'aération à ce moment-là. N'inhalez les fumées de combustion à aucun moment, surtout au moment où elles sont émises. Cette période de combustion ne durera que quelques minutes.

7.3 Lighting and Shutdown Procedures

Before starting your heater, be sure that you are familiar with the setting and operation of the heater controls. Once the controls are set to your preferences, follow the instructions outlined on the following page.

Read and follow all safety instructions first.

A more detailed set of instructions of the operation of the LG controller follows in the next section.

NOTE: If your heater is configured to operate on LP gas and the LP tank runs out of fuel, turn off gas at the heater. After the tank is refilled, the heater must be relit following the instructions found on the inside of the heater. A copy of these instructions appear on the following page. **DO NOT** attempt repairs on the gas control or heater. Tampering is dangerous and voids all warranties.

⚠ WARNING

Do not attempt to operate the heater with the door off. Doing so may cause severe bodily injury.

⚠ AVERTISSEMENT

Ne tentez pas d'opérer l'appareil sans que la porte soit en place. Vous pourriez être victime de blessures corporelles graves.

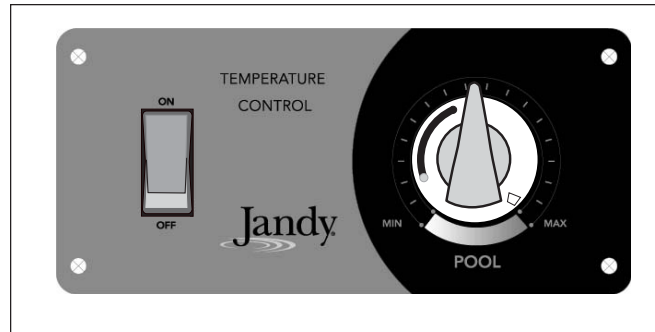

Figure 18. Temperature controls.

7.4 Turning the Heater On/Off and Setting the temperature control

The temperature control (see Figure 18) is calibrated at the factory and covers a range from approximately 70°F to 104°F (21°C to 40°C). Use an accurate pool thermometer to determine the best water temperature for your uses.

The Lite2 temperature control panel has a rocker switch to turn the heater on and off. It also has a rotary dial to set the desired thermostat setting (see Figure 18).

Once the heater has been lit by following the safety and lighting procedures in Section 7.3, set the toggle switch on the control panel to "ON" to start the heater operation. If the heater senses that the pump is on and the thermostat setting is higher than the temperature of the pool/spa water, the pilot will ignite the main burners.

NOTE: The heater is designed to run only when the filter pump is running. If the heater does not immediately turn off when the pump turns off, turn the heater off at the control panel. The heater's pressure switch may need adjusting (see Section 7.5)

Once the pool/spa water temperature reaches the thermostat setting, the heater will automatically stop firing. As the pool/spa water temperature falls below the thermostat setting the heater will once again start the heating cycle.

Rotate the thermostat dial clockwise to increase the temperature setting and counterclockwise to decrease the setting. It may take several attempts to set the thermostat dial to the desired temperature. Be sure to use an accurate thermometer to measure water temperature. Once the desired temperature setting is found, loosen the screw on the Temp-Lok ring and rotate the ring until the stop rests against the knob. Tighten the screw to hold the knob in position. This will prevent accidental moving of the dial and possible overheating of the water.

FOR YOUR SAFETY READ BEFORE OPERATING

PRÉCAUTIONS À LIRE AVANT D'UTILISER



⚠WARNING: If you do not follow these instructions exactly, a fire or explosion may result, causing property damage, personal injury or loss of life.

⚠AVERTISSEMENT : Si vous ne suivez pas ces instructions à la lettre, il y a risque d'incendie ou d'explosion, pouvant entraîner des dégâts matériels et des blessures graves voire mortelles.

LIGHTING INSTRUCTIONS

INSTRUCTION D'ALLUMAGE



INSTRUCTIONS TO LIGHT HEATER

1. Position ON/OFF switch to "OFF".
2. Turn gas control knob clockwise  until it stops at "OFF" position.
3. Wait five (5) minutes before lighting pilot.
4. Turn knob on gas valve counterclockwise  to "PILOT" then push control knob all the way and hold down. Push the button of the sparker, repeating until confirming that pilot lights, by observing reflection on burner tray mirror. Continue to hold the control knob in for about one (1) minute after the pilot is lit. If it goes out, repeat steps 3 and 4.
5. Turn gas control knob counterclockwise  to "ON".
6. After replacing door, set thermostat to desired setting and turn appliance ON/OFF switch to "ON". Valve has built-in delay before coming on.

RELIGHTING



If pilot goes out, repeat steps 1 through 6.

TO SHUT OFF HEATER

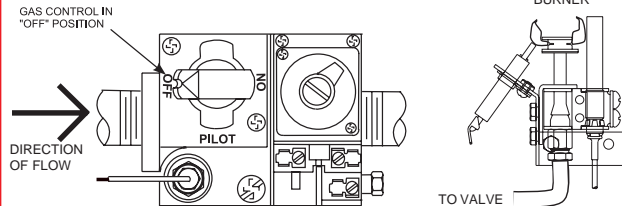
To shut off main burners turn gas control knob clockwise  until it stops at "PILOT". For complete shut-off press down slightly on knob while turning clockwise  to "OFF". Do not force. Position ON/OFF switch to "OFF".





INSTRUCTION D'ALLUMAGE DU CHAUFFE-PISCINE

1. Placer l'interrupteur général de l'appareil à la position "OFF".
2. Faire tourner le bouton du robinet à gaz vers la droite  jusqu'à ce qu'il s'arrête à la position "OFF".
3. Attendre cinq (5) minutes avant d'allumer la veilleuse.
4. Faire tourner le bouton du robinet à gaz vers la gauche  jusqu'à la position "PILOT" puis enfoncer le bouton complètement à fond et le maintenir dans cette position. Faire tourner le bouton de la génératrice d'étincelles de façon répétée jusqu'à confirmer que la veilleuse s'est allumée en observant sa réflexion sur la cuvette du bec de gaz. Continuer à maintenir le bouton en position enfoncée pendant environ une (1) minute après l'allumage de la veilleuse. Si elle s'éteint, répéter les étapes 3 et 4.
5. Faire tourner le bouton du robinet à gaz vers la gauche  jusqu'à la position "ON".
6. Après avoir remis en place le panneau d'accès, régler le thermostat sur la valeur voulue, et mettre l'interrupteur général de l'appareil sur la position "ON". Le robinet à gaz incorpore un retardement d'allumage.

RÉALLUMAGE

Si la veilleuse s'éteint, répéter les étapes 1 à 6.

POUR ARRÊTER LE CHAUFFE-PISCINE

Pour éteindre les brûleurs principaux, faire tourner le bouton du robinet à gaz vers la droite  jusqu'à ce qu'il s'arrête à la position "PILOT". Pour arrêter complètement l'appareil, enfoncer le bouton et continuer à le faire tourner vers la droite  jusqu'à la position "OFF". Ne pas forcer. Mettre l'interrupteur général sur la position "OFF".

IMPORTANT INFORMATION

RENSEIGNEMENTS IMPORTANTS

1. CAUTION: Do not store pool chemicals or flammable materials near this appliance.
2. PH LEVEL: Pool Water must be maintained between 7.4 and 7.6 when operating unit (See section entitled "Water Chemistry" in operating manual).
3. BACKWASHING: Turn heater off 20 minutes before backwashing or shutting down filter to prevent damage to unit.
4. WINTERIZE: All gas to unit must be shut off and all water drained from unit to protect it from freezing damage.

NOTE: THIS DOOR MUST BE FITTED TO UNIT DURING NORMAL OPERATIONS.

1. AVERTISSEMENT: Ne pas ranger de produits chimiques ni de matériaux inflammables près de cet appareil.
2. NIVEAU DE pH de l'eau de la piscine doit rester entre 7.4 et 7.6 pendant le fonctionnement de l'appareil. (Voir la section autorisée "la Chimie d'Eau" du manuel d'utilisation.)
3. RETRE-RINCAGE: Arrêter le chauffe-eau 20 minutes avant le rétro-rincage ou l'arrêt du filtre pour éviter d'endommager l'appareil.
4. PRÉPARATION POUR L'HIVER: Couper l'alimentation en gaz de l'appareil pour le protéger du gel.

REMARQUE: CETTE PORTE DOIT ÊTRE BIEN AJUSTÉE SUR L'APPAREIL PENDANT SON FONCTIONNEMENT NORMAL.

FOR YOUR SAFETY

AVERTISSEMENT DE SÉCURITÉ

DO NOT STORE OR USE GASOLINE OR OTHER FLAMMABLE VAPORS OR LIQUIDS IN THE VICINITY OF THIS OR ANY OTHER APPLIANCE.

NOTE: SOME EXPOSED PARTS OF THIS HEATER MAY BE HOT WHEN OPERATING.

NE PAS ENTREPOSER NI UTILISER DE L'ESSENCE OU TOUTE AUTRE VAPEUR ET LIQUIDE INFLAMMABLES AUX ALENTOURS DE CET APPAREIL OU DE TOUT AUTRE APPAREIL.

REMARQUE: PENDANT LE FONCTIONNEMENT, CERTAINES PIÈCES EXPOSÉES DE CE CHAUFFE-PISCINE PEUVENT DEVENIR TRÈS CHAUDES.



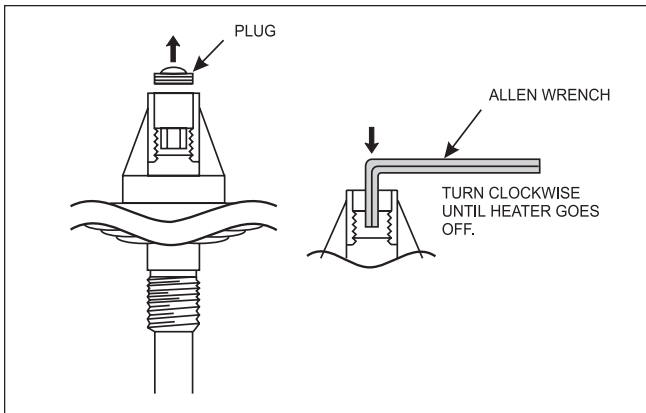

Figure 19. Pressure switch adjustment.

IMPORTANT: The temperature controls cannot be calibrated in the field. If the control is faulty, shut down the heater by following the procedures in Section 7.3 and have a qualified service technician replace the control. **DO NOT** use the thermostat switch to completely shut down the heater.

7.5 Water Pressure Switch Adjustment

⚠ CAUTION

The water pressure switch should be adjusted to turn the heater off when the pump is off. Setting the switch to close at too low of a flow can damage the appliance. Adjust the switch to turn the heater off, not on.

⚠ ATTENTION

Le manocontact de pression d'eau doit être réglé de façon à ce que l'appareil cesse de fonctionner si la pompe s'arrête. Si le manocontact est réglé pour se fermer lorsque le débit d'eau est trop faible, l'appareil risque de s'endommager. Réglez le manocontact pour qu'il arrête l'appareil, et non pour qu'il le mette en marche.

The pressure switch is preset at the factory for activation at 2 psi (14 kPa). Adjust the pressure switch only if any part of the filter system piping is 3 feet (0.91 m) or more above the top of the heater jacket.

Do not adjust the pressure switch if the heater is installed more than 15 feet (4.57 m) below or 6 feet (1.83 m) above the pool surface. Consult your local Jandy representative for recommendations.

On some installations, the piping from the heater to the pool is very short. The back pressure could be too low to trigger the pressure switch. If this happens, it may be necessary to install a directional fitting or elbows where the return line enters the pool. This will increase back pressure enough for the heater to operate properly.

Make sure the pool filter is clean before making any pressure switch adjustment. A dirty filter will restrict the water flow and the pressure switch cannot be adjusted properly. To adjust the pressure switch:

1. Set the control panel rocker switch to the OFF position (see Figure 18).
2. Set the Pool temperature control to the Max position.
3. Turn filter pump on. If a two-speed pump is used, make sure it is at high speed.

NOTE: If using a two-speed pump, the heater should not be allowed to fire on low speed.

4. Set the rocker switch to ON. Heater should start.
5. Pry out the top rubber dust plug on the top of the pressure switch.
6. Use a 7/32 inch (5.55 mm) Allen wrench to turn the adjustment screw very slowly clockwise until the heater goes off (see Figure 19).
7. Slowly turn the pressure switch adjustment screw **counterclockwise** one-quarter turn. The heater should come back on.
8. Check the adjustment by turning the filter pump OFF. The heater should shut off immediately. If it does not, restart the filter pump and repeat Steps 6 and 7. Check the adjustment again.
9. Return the pool temperature control to the desired temperature.

7.6 Temperature Rise

The automatic flow control valve (see Section 5.2) maintains the proper flow through the heater at rates up to approximately 125 gallons per minute (GPM) (475 liters per minute [LPM]).

A temperature rise test confirms proper water flow through the heater. The temperature rise is the difference between the temperature of the pool or spa water before and after heating, as measured in the header. Perform the following temperature rise test when the installation is complete:

1. Make sure the pool filter is clean.
2. Set the rocker switch on the temperature control panel (see Figure 18) to OFF.
3. Turn the filter pump OFF.
4. Remove the drain plug located on the inlet/outlet header of the heater and replace it with a Pete's plug (see Figure 15).

5. Insert a pocket thermometer (see Figure 14) through the Pete's plug into the header.
6. Turn the filter pump ON and wait 3 minutes. The heater remains OFF. This allows water from the pool to reach the heater.
7. Record the temperature indicated by the thermometer (cold water).
8. Turn the heater ON following the lighting instructions found on the inside of the heater.
9. Allow the heater to run for about 3 minutes. Record the new temperature reading (heated water).
10. Subtract the first temperature reading (cold water) from the second temperature reading (heated water). The difference between the two readings is the *temperature rise*. The temperature rise should be within the range shown in Table 6.
11. If the temperature rise is below the minimum range indicated, two possibilities arise:
 - a. The supply gas volume is too low.
 - b. The system's water flow exceeds 125 GPM (475 LPM), and requires a manual bypass valve for proper operation (see Figure 7).
12. If the temperature rise is above the maximum, there is not enough water flowing through the heater. Check for clogging in the water filter or restriction in the water pipes.

13. If the temperature rise is within the correct range, complete the procedure as follows:
 - a. Turn heater OFF.
 - b. Wait 3 minutes, turn filter pump OFF.
 - c. Remove thermometer and Pete's plug.
 - d. Replace the drain plug.

7.7 Adjusting the Manual Bypass Valve

If a manual bypass valve is installed, use the following procedures to adjust the bypass valve:

1. Clean pool filter.
2. Remove drain plug located on the inlet/outlet header of the heater and replace it with a Pete's plug.
3. Insert a pocket thermometer (see Figure 15) through the Pete's plug into the header.
4. Close manual bypass valve.
5. Turn on the temperature control to the OFF position.
6. Repeat steps 6 through 10 of the temperature rise test (see Section 7.6).
7. If the temperature rise is below the minimum stated in Table 6, open the manual bypass valve until temp rise climbs between the min. and max. range for your size heater. If the minimum temperature rise stated in Table 6 cannot be reached with the manual bypass fully open, then the gas supply volume is too low.
8. If the temperature rise is above the maximum, there is not enough water flowing through the heater. Check for clogging in the water filter or restriction in the water pipes.
9. Once the temperature rise is within the correct range, safety wire the handle of the manual bypass valve in place and tag the valve to prevent change in the water flow.

⚠ CAUTION

Operating the heater with the temperature rise above maximum or below the minimum can damage the heater and may void the warranty.

⚠ ATTENTION

Opérer le chauffe-piscine au-dessus du niveau de température maximale ou sous le niveau de température minimale recommandée, peut endommager le chauffe-piscine et ainsi annuler la garantie.

Table 6. Temperature Rise and Minimum Flow Rates

Size	Minimum		Minimum		Maximum	
	GPM	(LPM)	°F	(°C)	°F	(°C)
125	20	(76)	27	(15)	36	(20)
175	20	(76)	33	(19)	42	(24)
250	25	(95)	33	(19)	42	(24)
325	30	(114)	28	(16)	38	(21)
400	30	(114)	30	(17)	39	(22)

SECTION 8. Maintenance

8.1 Water Chemistry

The mineral content of swimming pool water increases daily due to natural evaporation and the addition of sanitizing chemicals. If the mineral concentration in the pool gets too high, the excess minerals will deposit on the walls of the pool, in the filter system, and in the heater tubes.

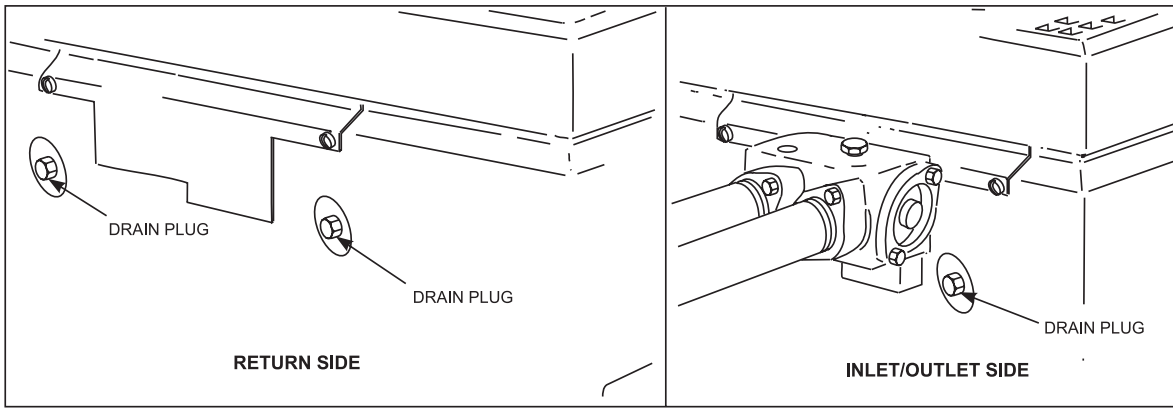

Figure 20. Heater drain locations.

The proper chemical balance in spa water is more critical than in a swimming pool heater operation. Due to the spa's size, high water temperature and heavy usage, chemical values in a spa can vary greatly. This chemical imbalance can result in unsanitary water conditions, and affect the life of the heater.

Proper chemical balances are necessary for sanitary bathing conditions as well as ensuring your heater's long life. Kits are available from your local pool supply dealer for making the various tests for mineral content. One of these kits will detect copper in the system. This is usually a warning that corrosion is taking place, possibly due to a low pH value combined with other chemistry problems. The condition can be corrected by changing the spa water and closely monitoring the pH factor and chemical properties of the water. Be sure to keep your chemical levels within the values indicated in Table 7. **Water Pik Technologies does not warrant heat exchangers damaged by corrosive chemical levels or excess dissolved solids in pool or spa water.**

For spas, it is also necessary to perform water changes in addition to chemical treatment. It is recommended to change the spa water every 60 days for light usage and every 30 days if usage is heavy.

Table 7. Chemical Concentration Levels*

Test	Recommended Level
Free Chlorine or	1.0 to 3.0 ppm (3.0 to 5.0 spa)
Bromine	2.0 to 4.0 ppm (3.0 to 5.0 spa)
pH	7.4 to 7.6
Total Alkalinity (TA)	80 to 120 ppm
Calcium Hardness (CH)	200 to 400 ppm
Cyanuric Acid	30 to 50 ppm
Total Dissolved Solids (TDS)	Less than 2000 ppm
Copper	0 ppm

* Concentration levels taken from "Basic Pool and Spa Technology" published by NSPI (National Spa and Pool Institute).

8.2 Seasonal Care

⚠ CAUTION

Do not operate this heater outdoors at temperatures below 20 degrees Fahrenheit (°F) (-7 degrees Celsius [°C]).

⚠ ATTENTION

Ne faites pas fonctionner cet appareil à l'extérieur à des températures inférieures à 20 degrés Fahrenheit (°F) (-7 degrés Celsius [°C]).

8.2.1 Spring and Fall Operation

During periods when the pool is only going to be used occasionally, turn the temperature control down to the MIN setting. This prevents the pool water from becoming chilled, and minimizes the time required to raise the pool water back up to the desired temperature.

In areas subject to only short freeze periods, turn off the heater and run the pump continuously for the length of the freeze period.

If the heater is not going to be used for a long period of time, shut it down completely. Follow the instructions found on the inside of the heater, or page 21 of this manual.

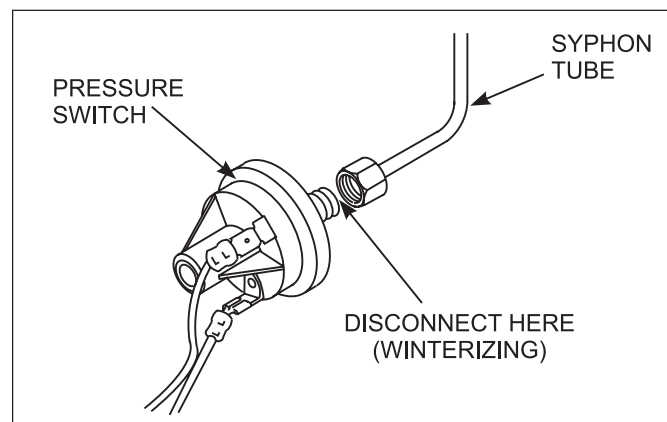

Figure 21. Pressure switch copper tubing.

8.2.2 Winterizing

In areas where freezing temperatures occur in winter, and the pool or spa will not be used, have your service technician perform the following steps:

1. Turn off the main gas supply valve to the heater, outside the heater jacket.
2. Remove heater door.
3. Shut down the heater following the shutdown instructions found on the inside of the heater or on page 21 of this manual.
4. Remove the drain plug from the return header (see Figure 20), loosen the drain plug from the inlet/outlet header, and completely drain the heater before the first frost.
5. After all water has drained from the heater, remove the drain plug from the inlet/outlet side. Check for mineral buildup in the openings.
6. Use compressed air to blow out any standing water remaining in the heat exchanger.
7. Grease the threads on the drain plugs and reinstall plugs, but do not tighten.
8. Disconnect the pressure switch from the siphon tube (copper tubing) (see Figure 21).

8.2.3 Spring Start-up

To restart the heater in the Spring, have a professional service technician reassemble the heater as follows:

1. Attach the copper tubing to the pressure switch (see Figure 21).
2. Tighten the drain plugs.
3. Turn on the filter pump and circulate water through the heater for 5 minutes. Check for leaks while circulating.
4. Turn on the main gas supply valve to the heater, outside the heater jacket.
5. Turn on the heater following the lighting instructions found on the inside of the heater, or page 21 of this manual.

8.3 Inspection and Service

The Lite2 LG heater is designed and constructed heater to provide long performance life when installed and operated properly under normal conditions. Periodic inspections, especially at spring start-up, are important to keep your heater running safely and efficiently through the years. Improper maintenance

can result in conditions where nausea or asphyxiation from carbon monoxide or flue gases could cause severe injury, property damage or death.

WARNING

Improper installation or maintenance can cause nausea or asphyxiation from carbon monoxide in flue gases which could result in severe injury, or death.

AVERTISSEMENT

Une installation ou un entretien inadéquat peut causer la nausée ou l'asphyxie en raison du monoxyde de carbone présent dans les gaz de combustion et même entraîner des blessures graves ou la mort.

8.3.1 Owner Inspection

Water Pik Technologies recommends that you inspect the heater on a continual basis and especially after abnormal weather conditions. The following basic guidelines are suggested for your inspection:

1. Keep the top and surrounding area of the heater clear of all debris.
2. Keep the area around and beneath the heater clean and free of all combustible materials such as paper, leaves, etc.
3. Do not store or use gasoline or other flammable vapors, liquids or chemicals in the vicinity of this or any other appliance.

Ne pas entreposer ni utiliser d'essence ni d'autres vapeurs ou liquides inflammables à proximité de cet appareil ou de tout autre appareil.

4. Do not use the heater if any part has been under water. Immediately call a qualified professional technician to inspect the heater and replace any part of the control system which has been submerged.

N'utilisez pas cet appareil s'il a été plongé dans l'eau, même partiellement. Faites inspecter l'appareil par un technicien qualifié et remplacez toute partie du système de contrôle et toute commande qui ont été plongés dans l'eau.

5. If the heater is equipped with a pressure relief valve, check for corrosion in and around the valve. With the filter pump on, lift the release lever on the top of the valve to make sure that water runs freely through it. If corrosion is found, replace the pressure relief valve. When

replacing the valve, be sure that the pump is off. Install the valve so that the discharge is directed away from any area that may be damaged by water.

6. Be sure all combustion air and ventilation openings are not blocked. Check for spider webs and other debris inside the heater, in the vents on all sides of the heater jacket and in the exhaust outlet— especially after a long period of nonuse.

8.3.2. Professional Inspection

Inspections performed at least once a year by a qualified technician are required to maintain your heater's safe and efficient operation. The following basic safety checks must be performed.

1. Inspect the venting system for blockage, leakage, and corrosion.
2. Inspect burners and verify that they are clean. Clean with a wire brush if necessary to remove debris.
3. Check for spider webs and other debris in the pilot and main burner orifices - especially at spring start-up.
4. Check for loose or broken wires and terminal connections.
5. Make sure that the pressure switch operates properly by shutting the filter pump off and on a few times. The burner should go off immediately after the pump stops. An ignition sequence should start shortly after the pump is turned back on.
6. Make a visual check of the main burner flame.
 - a. Blue in color.
 - b. 1 to 4 inches (25mm to 102mm) above burner surface (see Figure 22).
7. Inspect the gas and electronic controls, including the following:
 - a. High temperature limit switch
 - b. Water pressure switch
 - c. Automatic gas valve
 - d. Fusible Link
 - e. Temperature control
 - f. Control circuit fuse
8. Perform a temperature rise test in accordance with Section 7.6.
9. If the heater is equipped with a pressure relief valve, check for corrosion in and around the valve. With the filter pump on, lift the release

lever on the top of the valve to make sure that water runs freely through it. If corrosion is found, replace the pressure relief valve. When replacing the valve, be sure that the pump is off. Install the valve so that the discharge is directed away from any area that may be damaged by water.

10. Inspect the external surfaces of the heat exchanger tubes for black carbon soot buildup by placing a mirror between and under the burners when the heater is firing. Remove any soot that has collected on the tubes, and correct the cause.

NOTE: After installation and first start-up, check the heat exchanger for black carbon soot buildup after the following periods of operation: 24 hours, 7 days, 30 days, 90 days, and once every 6 months thereafter.

11. Conduct a normal operating cycle and observe that the sequence proceeds as intended.

CAUTION

For your safety, when starting the heater, keep your head and face away from the burner area opening to prevent any risk of personal injury.

ATTENTION

Pour votre sécurité personnelle, lorsque vous mettez l'appareil en marche, tenez votre tête et votre visage loin du brûleur pour éviter tout risque de blessure.

NOTE: Keep this manual in a safe place for future reference by you and your professional technician when inspecting and servicing the heater.

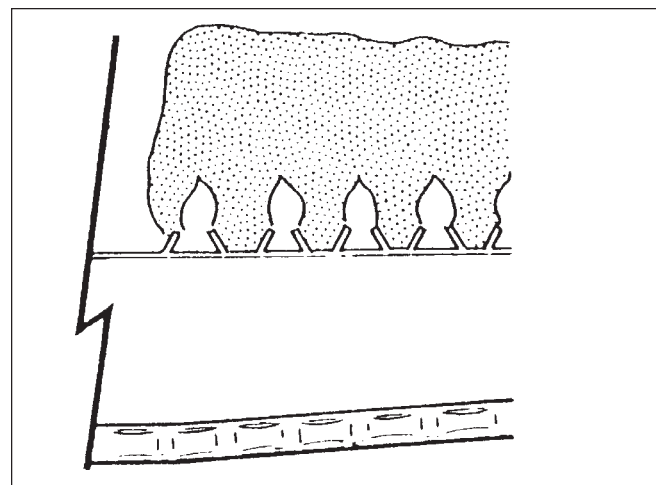

Figure 22. Main Burner Flame.

SECTION 9. Troubleshooting

9.2 Trouble Shooting Guide

#	Symptom	Cause	Remedy
1.	Pump not operating	A. No power B. Pump defective C. Incorrectly wired	A. Check circuit breakers and power source. B. Replace. C. Recheck wiring.
2.	Pilot outage	A. Inlet gas pressure too low B. Inlet gas pressure too high causing an unstable blowing pilot C. Weak or defective thermocouple D. Damaged pilot or thermocouple E. Dirty pilot F. Plugged or undersized pilot orifice	A. Consult gas utility company. Inlet gas pressure to heater should be 5.5" to 10.0" water column on natural gas. 10.0" to 14.0" on propane gas. B. Pressure should be regulated within limits shown above. C. Replace thermocouple. D. Replace. E. Blow dust or lint out of pilot. F. Clean or replace pilot orifice.
3.	Flame roll-out on start-up	A. Blocked flue B. Pilot out of position (delayed ignition) C. Blocked heat exchanger D. Refractory blanket out of place E. Altered draft hood	A. Remove blockage. B. Correct pilot position. C. Clean and correct as necessary. D. Correct or replace blanket as necessary. E. Install factory-provided draft hood.
4.	Spillage at draft hood	A. Cold chimney B. Vent pipe pitches down to chimney C. Blocked chimney D. Draft hood altered E. Prefabricated chimney with incorrect cap	A. Allow heater to operate 5 minutes to create draft action. B. Reinstall vent pipe to pitch up from heater to chimney. C. Remove blockage. D. Install factory-provided draft hood. E. Install U.L. listed vent cap.
5.	Flame has lazy yellow tip	A. Low primary air	A. Correct manifold pressure according to rating plate. Correct orifice size if necessary (see parts list). Clean burner ports if dirty.
6.	Not enough heat	A. Inadequate gas supply B. Low manifold gas pressure C. Heater size inadequate	A. Gas meter too small. Gas line from meter to heater too small. B. Gas pressure on heater manifold, should be adjusted to 4.0"W.C. for natural gas, 9.0"W.C. for propane. C. Replace with heater of higher input.
7.	Heater pounding or knocking	A. Inadequate water flow through heater	A. Check temperature rise between inlet and outlet heater piping. See section 7.6 for recommended range of temperature rise. If temperature rise is above the maximum recommended, increase pipe size or pump capacity or locate obstruction. Check for closed valve in system.
8.	Heater condensing	A. Low water temperature	A. Flue product moisture will condense at the start-up until the heater water temperature reaches the normal operating conditions.
9.	Pressure relief valve opens	A. Restriction in water flow system at or downstream of heater.	A. Check for proper operation of all valves, bypass valve and any equipment between pool and heater outlet.
10.	Pilot is lit but main burners will not come on	A. Gas valve not at "on" position B. Hi-limit switches failed C. Pressure switch failed or out of adjustment D. Fusible link failed E. Gas valve failed F. Broken wire in thermostat circuit or defective thermostat G. Heater wired incorrectly	A. Turn knob to "on" position. B. Investigate reason for overheating and replace hi-limit switch as necessary . C. Adjust pressure switch (see Section 7.5) or replace as necessary. D. Investigate reason for flame rollout and replace fusible link as necessary . E. Check and replace gas valve as necessary. F. Check continuity through thermostat circuit with wires disconnected. G. Check heater wiring against wiring diagram on page 18, correct as necessary.
11.	Heater short cycles	A. Low water flow through heater B. Failing hi-limit switch	A. Increase size of pump or increase piping size. B. Check High limit switches and replace as necessary.

9.1 General Heater Troubleshooting

The following table lists some of the more common problems, causes and solutions encountered when running the heater. Most problems occur when the heater is being started for the first time after installation or at Spring start-up. Careful installation and maintenance will help ensure years of trouble free use from your Lite2 pool heater.

SECTION 10. Professional Maintenance, Service and Diagnostic Trouble Shooting

WARNING

SERVICING SAFETY

Some of the servicing procedures for the Lite2 model LG pool heater are hazardous because they involve fuel gas, moving parts and procedures which require testing or temporary bypass of safety controls. For this reason, the heater must be serviced only by a qualified professional service technician.

IMPROPER SERVICE HAZARD

The Lite2 model LG pool heater incorporates unique design features. Incorrect service of this heater can result in personal injury or damage to property. To avoid such hazards, the heater must be serviced only by a qualified professional service technician.

AVERTISSEMENT

PRÉCAUTIONS LORS DES RÉPARATIONS ET DE L'ENTRETIEN

Certaines procédures d'entretien et de réparation des appareils de chauffage à LG présentent des dangers, car elles mettent en jeu des gaz combustibles, des pièces mobiles et des procédures qui nécessitent des mises à l'essai ou la dérivation temporaire des commandes de sécurité. Pour cette raison, l'appareil de chauffage doit être entretenu et réparé uniquement par un technicien professionnel qualifié.

DANGERS D'UN ENTRETIEN INADÉQUAT

Les appareils de chauffage à LG comportent des caractéristiques techniques uniques. Une réparation ou un entretien inadéquat peut entraîner des blessures corporelles ou des dommages à la propriété. Pour cette raison, l'appareil de chauffage doit être entretenu et réparé uniquement par un technicien professionnel qualifié.

10.1 General Information

A qualified professional technician must service the Lite2 model LG pool heater using Water Pik Technologies, Inc. service procedures. Before calling for service, however, the owner should check for obvious problems. The other components in the pool system, including pump, filters and strainers, water valves, gas supply and time clocks have an effect on heater operation.

Confirm that the LG heater control switch is set to 'ON' and that the temperature control knob is set high enough to make the heater operate. Make sure the pump is operating, that the filter and strainers are not clogged, that there are no mis-positioned water valves, that the gas is not shut off and that time clocks are properly adjusted. Also be sure that there is no blockage of the vent or louvers which supply combustion air to the burners.

10.2 Natural-Draft Combustion System

The Lite2 model LG pool heater has an atmospheric combustion system. This system is illustrated in Figure 23.

As the heated exhaust gases rise out of the combustion chamber, flow is created through the system and fresh combustion air is drawn into the heater through the louvers cut into the front and sides of the heater. Gas is forced through an orifice into the open end of a burner. When the gas flows into the burner, a "negative" pressure is created at the opening of the burner. This negative pressure pulls air into the burner with the gas and mixes the two together. As the gas/air mixture flow through the burner ports it is ignited in the combustion chamber. Hot combustion products then rise through a highly efficient heat exchanger. Combustion products then enter a flue collector and are directed to the outdoors through the grate top of the heater or a vent pipe and cap.

10.3 Heater Components and Their Operation

1. **Gas Valve / Regulator** - The gas valve controls gas flow into the manifold. It provides flow only when the temperature controls require heat and only if all safety controls enable operation. It is also a *positive pressure regulator*. It regulates the gas pressure in the manifold to specifications addressed earlier in this manual. This is necessary for proper operation of the burner system.
2. **LG Temperature Control**- The Jandy LG controller is an electronic control which senses water temperature by means of a thermistor and controls heater operation to bring the water to the

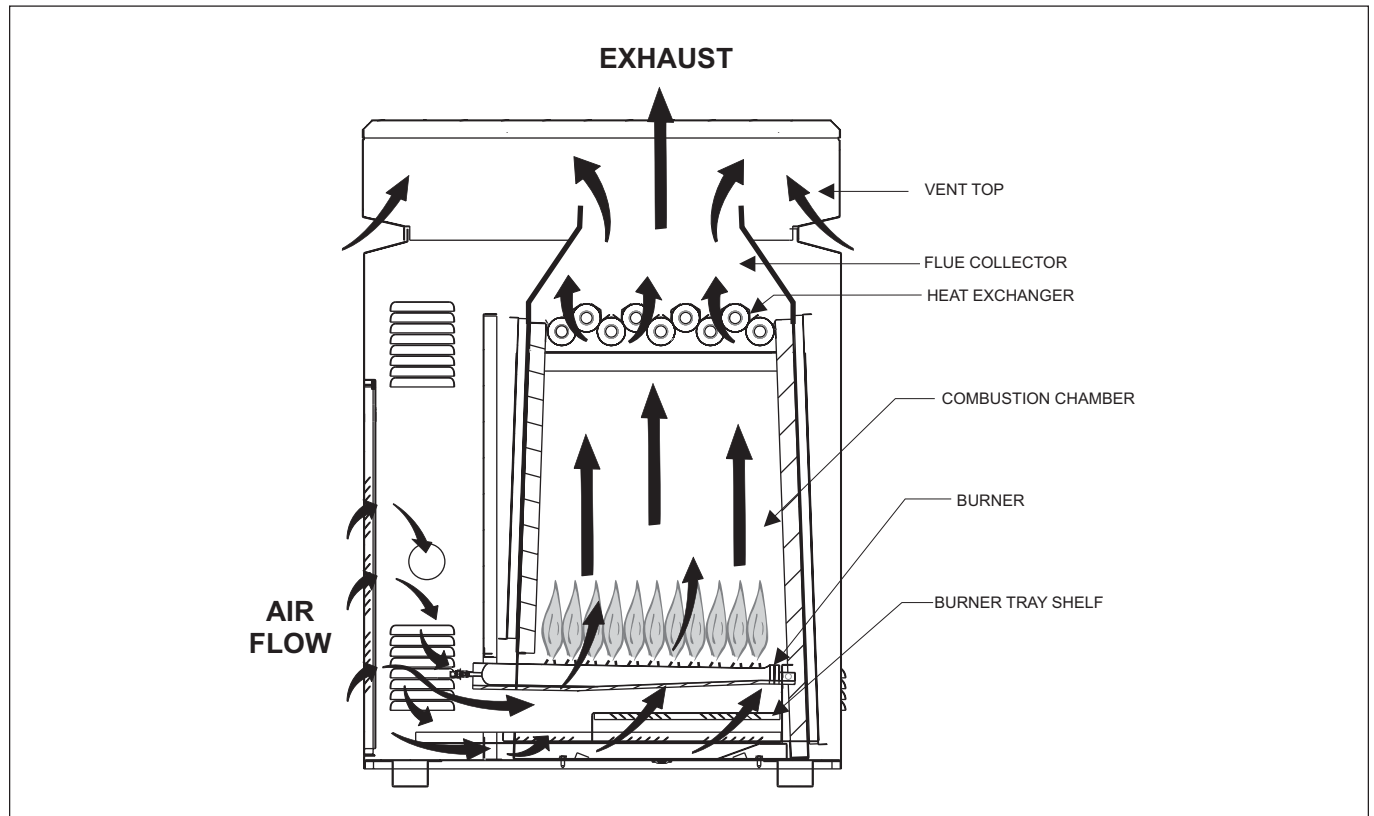

Figure 23. Atmospheric Combustion System

desired temperature. The desired temperature is set by rotating a knob on the face of the control panel. To achieve accurate water temperatures, the pool/spa water must be monitored with an accurate pool thermometer.

3. **Pilot/Pilot Ignition**

The LG heater relies on a standing pilot to ignite the burners when the temperature control calls for heat. When lit the pilot receives a constant flow of gas from the gas valve. If the pilot extinguishes, the gas valve is automatically signalled to stop the flow of gas to the pilot and the burners to prevent a gas build up in the heater. Igniting the pilot is achieved by means of a piezo spark igniter mounted on the inner front panel of the controls compartment of the heater.

4. **Pilot Generator (Thermopile)** - The pilot generator is a device, that when heated by the flame of the pilot, generates a small electrical voltage of approximately 750 millivolts. The voltage is placed across the temperature controller and safety circuit of the heater. If this current is broken at any time, the gas valve is immediately shut off and the heater stops firing. This voltage is also used to activate the gas valve's pilot coil which allows gas to flow to the pilot after the gas valve knob is released.

5. **Limit Switches** - Two limit switches prevent excessive water temperature - one within the heat exchanger and one for water leaving the heater. If either senses excessive temperature, burner operation is interrupted.
6. **Water Pressure Switch** - This control senses whether or not water is available to the heater by measuring back pressure inside of the heat exchanger. If the pool water pump fails or the water filter is blocked, the pressure switch prevents operation of the burner.
7. **Fusible Link** - This is a single-use switch which detects abnormal temperature in the component vestibule. It is a fusible link which is held to the inner panel just above the burner tray by a sheet metal bracket. Excessive temperature in the component compartment, possibly due to a blocked flue or flame roll-out, will cause the link to fail. This opens the safety circuit which shuts off the gas valve and shuts the heater down.

10.4 Electrical Troubleshooting

This section describes procedures for checking the pilot generator and control components of the heater one at a time and in the order they appear in the control circuit.

Note: Pump must be running during the troubleshooting procedure.

These procedures require a voltmeter with a minimum 0-1000 mVDC range. Figure 24 shows the pilot generator and control circuits, and where to take measurements. Location numbers and letters in circles have been added, and will be referenced in the following sections.

As stated at the beginning of this manual, some of these procedures are hazardous. Only a qualified service technician should service the heater.

During the trouble shooting procedure, the filter pump must be on, the pilot on the heater must be lit, the ON/OFF switch on the heater must be in the ON position and the control knob must be turned to the maximum setting so that there is a call for heat. We recommend turning the gas valve control knob to the "PILOT" position to prevent the main burners from firing throughout the procedure. Before starting the procedure, be sure that the pilot has been lit for at least 2 minutes and that the pilot generator (thermopile) is positioned correctly within the flame of the pilot.

The pilot generator also operates the pilot coil of the gas valve, allowing gas to flow to the pilot when the gas valve knob is released from the pilot lighting position (see Section 7.3 "Lighting and Shutdown Procedures"). If the pilot will not stay lit when the gas valve knob is released, check the pilot generator output as described in Section 10.4.2 and replace if necessary. If the pilot generator output is sufficient, then check the gas valve as outlined in Section 10.4.1.

10.4.1 Gas Valve

The gas valve consists of two separate internal operating valves. The main valve supplies gas to the main burners for heater operation. The pilot valve supplies gas to the pilot when the pilot generator activates the pilot coil.

If the pilot will not stay lit after following the lighting instructions in Section 7.3, check for the following:

- Pilot generator output
- Correct type of gas supplied
- Correct gas supply pressure
- Air in the gas line
- Pilot coil wire connections clean and tight

If the pilot will not stay lit after checking the items listed above, the pilot coil may be causing the fault. Replace the gas valve.

If the main burners will not light after following the lighting instructions in Section 7.3, check the voltage reading between the PP terminal on the gas

valve (test point 1) and the TH terminal on the gas valve (test point 17). If the meter shows less than 220mVDC then there is a problem with the pilot generator, the sensors in the safety loop or the control panel. Follow the trouble shooting procedure as outlined in sections 10.4.2 through 10.4.7.

If the meter shows more than 220mVDC at test point 17, then check for the following:

- Correct type of gas supplied
- Correct gas supply pressure
- Correct gas manifold pressure
- Correct orifice size
- Air in the gas line

If the main burners will not stay lit after checking the items listed above, the gas valve may be causing the fault. Replace the gas valve.

10.4.2 Pilot Generator

The pilot generator generates a 700-750mVDC signal when heated by the pilot flame. When the pilot generator is connected to the heater's control components, there will be some voltage drop in the circuit so that the measured voltage will be less than 750mVDC. But the measured voltage should never be below 500mVDC when the ON/OFF switch is in the "OFF" position or 220mVDC when the ON/OFF switch is in the "ON" position.

With the pilot generator connected to the gas valve and the ON/OFF switch in the OFF position, place the red lead of the voltmeter on the PP terminal (test point 1) of the gas valve. Place the black lead of the meter on the PP/TH terminal (test point 2) of the gas valve. The meter should show a minimum of 500mVDC. If the meter show less than 500mV, check for partial shorts, loose or corroded connections or partially broken wires between the pilot generator and the gas valve.

If the wires and connections are sound, check the pilot generator output. Disconnect the pilot generator from the gas valve. The pilot will go out. Light the pilot while pressing down on the gas valve control knob. Continue holding the knob for at least one minute. Immediately measure the voltage between the two wires of the pilot generator. If the meter does not show at least 700mV, replace the pilot generator.

10.4.3 Fusible Link

Check the voltage going to the safety circuit. Be sure that the pilot generator is correctly wired to the gas valve, the pilot is light and the control knob on the gas valve is in the "PILOT" position. Leave the red voltmeter lead in place at test point 1. Touch the black lead of the meter to the terminal of the fusible link where the white wire from the gas valve is connected (test point 3).

If no voltage is detected at test point 3, the wire between the gas valve and the fusible link is broken. Replace the wire.

If there is a minimum of 220mV at test point 3, move the black meter lead to the other terminal of the fusible link (test point 4).

If no voltage is detected at test point 4, the fusible link has failed. This indicates higher than normal temperatures in the component compartment (vestibule). Normal component compartment temperature is well below 300°F. The fusible link is designed to fail at temperatures above 305°F. Excessive temperature might be due to a blocked flue or heat exchanger. Clean the heat exchanger and clear the flue and vent of any restrictions. Sometimes the fusible link fails due to flame roll-out. Flame roll-out may be caused by delayed ignition or downdrafting in windy areas. Thoroughly investigate the causes for flame roll-out and correct the problem when replacing the fusible link.

10.4.4 Fireman Switch and External Interlocks

Check the voltage going to the external device. Touch the black lead of the meter to the fireman switch terminal strip where the white wire from the fusible link is connected (test point 5). The meter should read at least 220mV. If the voltage is less than 220mV, there may be a bad connection or wire between the fusible link and the terminal strip. The wire may need to be replaced. If voltage of 220mV or more is detected at test point 5, move the black lead of the meter to the fireman switch terminal strip connection where the white wire from the high limit is connected (test point 6). The meter should read at least 220mV. If there is no voltage, the time clock switch or other external interlock may be mis-adjusted, mis-connected or defective. Correct this external problem.

10.4.5 Limit Switches

Since the limit switches are not easily accessible, you can check the voltage going into the component after the limit switches in the circuit. If voltage is detected there, then the limit switches are closed and are operational.

Check the voltage going to the water pressure switch. Leave the red voltmeter lead in place at test point 1. Touch the black lead of the meter to the terminal of the water pressure switch where the white wire is connected (test point 11).

If the voltage is less than 220mV, there may be a bad connection, a partial short or a faulty sensor. If there is no voltage, one of the limit switches is open. This is normally due to excessive water temperature, which should be thoroughly investigated before

replacement of limit switches. Excessive water temperature may be caused by low water flow. Water flow deficiency may be due to obvious problems such as a defective pump or blocked water filter. Alternatively, excessive water temperature may be due to over-firing, or to a problem with the water piping or the heater's internal bypass control. Over-firing might be a result of an incorrect gas orifice or supply of propane gas to a heater intended for natural gas.

If there are no such fundamental problems, identify which of the switches is open. Limit switch access is through the limit switch cover on the inlet/outlet header. Remove the cover and retainer bracket from the high limit switches and remove the limit switches from the wells. Move the black lead of the meter to the terminal on the 150°F limit switch (test point 7) that is connected to the fireman switch terminal block. Less than 220mV at this point means that the wire between the terminal block and the limit switch has a poor or broken connection or a partial short. Replace the wire assembly. If at least 220mV is detected at test point 7, then move the black lead of the meter to the other terminal of the 150°F limit switch (test point 8). Low or no voltage here means that the limit is open and must be replaced.

If 220mV or more is detected at test point 8, move the black lead of the meter to the terminal on the 135°F limit switch (test point 9) that is connected to the 150°F limit switch. Less than 220mV at this point means that the wire between the two limit switches has a poor or broken connection or a partial short. Replace the wire assembly. If at least 220mV is detected at test point 9, then move the black lead of the meter to the other terminal of the 135°F limit switch (test point 10). Low or no voltage here means that the limit is open and must be replaced. If voltage is detected at test point 10, move the black lead of the meter to the terminal of the water pressure switch where the white wire from the high limits is connected (test point 11). Less than 220mV at this point indicates that the wire connecting the high limits to the water pressure switch is faulty or poorly connected. Correct the problem or replace the wire.

Note: The limit switches have different trip points, and it is important that replacements are correct. The 150°F switch has a red dot on the top of the brass fitting, and must be installed in the lower (horizontal) well in the header. The 135°F switch has no dot and must be installed in the upper (vertical) well in the header.

10.4.6 Water Pressure Switch

If the meter shows at least a 220mV signal at test point 11, move the black lead of the meter to the other terminal on the water pressure switch (test point 12).

If there is no voltage, the pressure switch contacts are open. This is almost always due to a water flow deficiency, the most common one being a blocked water filter or defective pump. However, sometimes it is due to blockage of the copper siphon loop tube or mis-adjustment of the switch. Investigate thoroughly, referring to Section 7.5 on "Water Pressure Switch Adjustment". If there is no problem with the pool system or pressure switch adjustment, replace the pressure switch.

10.4.7 Temperature Control Circuit

The temperature control circuit consists of four major components which must all be working correctly for the signal to be transmitted to the gas valve. The four components are the ON/OFF toggle switch, the variable temperature control (potentiometer), the temperature sensor (thermistor) and the temperature control board. Use the following procedure to check each component for functionality.

Check the temperature control as a complete circuit before checking each component individually. With the red lead of the meter still at test point 1, place the black lead of the meter on the TH terminal of the temperature control circuit board (test point 16). If the meter shows more than 220mV at the pressure switch (test point 12) but not at test point 16, then one of the components of the temperature control circuit is faulty. Proceed with the following sections to test the components.

10.4.7.1 ON/OFF Toggle Switch

Remove the temperature control panel from the bezel on the front of the heater to gain access to the switch. Be sure that the toggle switch is in the "ON" position. Place the black lead of the meter on the toggle switch terminal (test point 13) that is connected to the pressure switch. Less than 220mV at this point indicates that there is a problem with the black wire that connects the pressure switch to the toggle switch. If at least 220mV is detected at test point 13, move the black meter lead to the other terminal on the toggle switch (test point 14). A reading of less than 220mV here indicates a faulty switch. If the reading is more than 500mV, turn the switch "OFF" and then "ON" again to be sure that the internal contacts are working correctly. The volt meter reading should drop to zero when the switch is "OFF" and return to at least 220mV when the switch is placed back in the "ON" position.

10.4.7.2 Variable Temperature Control

The variable temperature control is a 0-10,000 ohm variable resistor. Set your ohmmeter to the 0-20K

range. Remove the temperature control wires from the control circuit board. Place one lead of the meter on each of the wires (test points 18 & 19). With the control set to MIN the meter should read near 10,000 ohms. Now turn the control to the MAX position. The meter should read close to zero. If the meter shows an open circuit, or readings outside of the range stated above, replace the controller. If the control is working correctly, reconnect the wires to the circuit board.

10.4.7.3 Temperature Sensor

The temperature sensor is a 0-20,000 ohm thermistor. Set your ohmmeter to the 0-20K range. The meter readings will depend on the temperature of the water in the header. See the chart below for approximate readings at various temperatures.

To test the temperature sensor, circulate water through the heater for 5 minutes. Remove the temperature sensor wires from the temperature control board. Place one lead of the meter on each wire of the temperature sensor (test points 20 & 21). Record the reading. Measure and record the water temperature of

WATER TEMP. IN HEADER °F (°C)	APPROX. RESISTANCE IN 1000'S OF OHMS (kOhms)
50 (10)	19.9
60 (15)	15.3
70 (21)	11.9
80 (26)	9.3
90 (32)	7.3
100 (38)	5.8

the pool near the inlet of the filter system. Find the temperature in the chart that is closest to your temperature reading of the pool water. Compare your ohmmeter reading to the resistance number in the chart. Remember that this is an approximate reading and numbers may vary. If your reading is close to the numbers indicated in the chart then the temperature sensor is working correctly. Reconnect the wires to the circuit board. If your reading is vastly different or outside of the ranges shown the temperature sensor should be replaced.

10.4.7.4 Temperature Control Circuit Board

With the red lead of the meter still at test point 1, place the black lead of the meter on the TH/PP terminal of the temperature control circuit board (test point 15). If there is more than 220mVDC at this point but not at the TH terminal of the temperature control circuit board (test point 16) as tested in section 10.4.7, then the control circuit board is faulty. Replace the board.

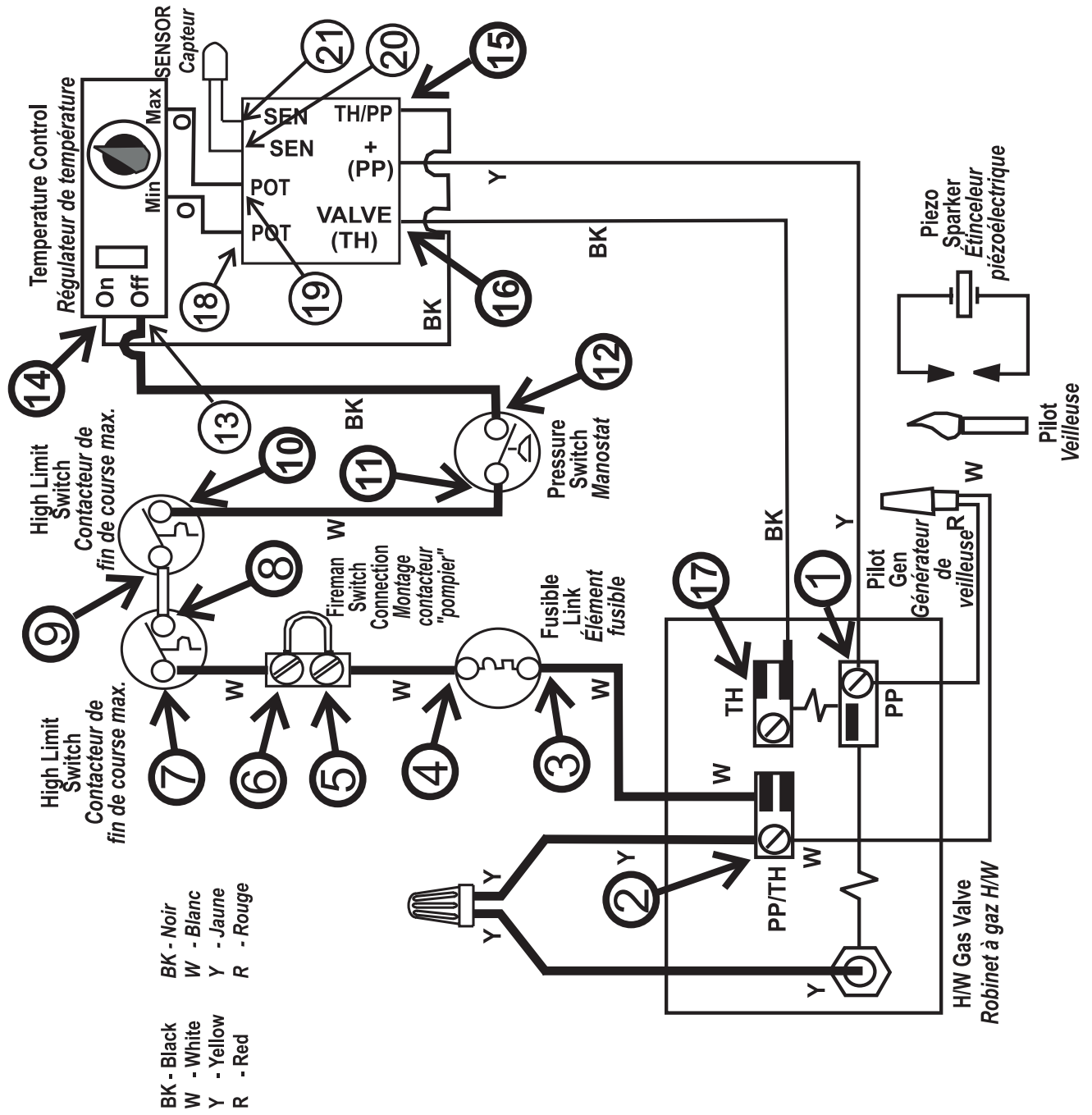

Figure 24. Test Point Identification Diagram

SECTION 11. Replacement Parts

11.1 Ordering Information

To order or purchase parts for the Lite2 model LG pool/spa heater, contact your nearest Jandy dealer or distributor. See the Jandy web page at www.Jandy.com for the nearest service center. If they cannot supply you with what you need, contact the Customer Service Manager at Water Pik Technologies, P.O. Box 6000, Petaluma, California, 94954, Telephone (707) 776-8200 extension 245.

NOTE: To supply the correct part it is important that you state the model number, serial number and type of gas when applicable. This information is on the rating plate inside the heater.

11.2 Parts List

The following three pages contain a parts list, general exploded view and detailed exploded views to aid in parts identification. Please refer to these pages when ordering parts for your Lite2 pool/spa heater.

Key No	Description	Model No	Order Part No.
PILOT/IGNITER SYSTEM			
1	Pilot, Main Burner Assembly, NAT	All	R0099100
1	Pilot, Main Burner Assembly, LPG	All	R0099200
2	Pilot Burner, NAT	All	R0096700
2	Pilot Burner, LPG	All	R0096600
3	Pilot Electrode	All	W0040000
4	Pilot Generator	All	W0036901
5	Ceramic Insulator Assembly	All	10418820
6	Burner, Main w/Pilot Bracket	All	10457500
7	High Voltage Lead Assembly	All	R0099000
8	Pilot Tubing	All	R0037000
9	Piezo Lighter Assembly	All	R0096800
10	Pilot Condensate Shield	All	R0323300
MAIN GAS ASSEMBLY			
11	Burner Tray Assy, NAT	125-400	R0098601-05
11	Burner Tray Assy, LPG	125-400	R0098701-05
12	Burner Tray, Shelf Only	125-400	R0317001-05
13	Gas Valve, NAT	All	R0096400
13	Gas Valve, LPG	All	R0096900
14	Gas Orifice, NAT 0 - 3,000 ft alt. (EA.) (Note 1)	All	L0032200
14	Gas Orifice, LPG 0 - 5,000 ft alt. (EA.) (Note 2)	All	L0032900
15	Anti-Rotation Bracket	All	10835900
16	Mounting Bracket Assembly	All	10419200
17	Burner, Main	All	L0052300
18	Burner Manifold	125	L0052200
18	Burner Manifold	175	L0006300
18	Burner Manifold	250	L0006400
18	Burner Manifold	325	L0006500
18	Burner Manifold	400	L0006600

Key No	Description	Model No	Order Part No.
ELECTRICAL SYSTEM			
19	Temperature Control Assembly	All	R0058200
20	Wire Harness	All	R0058000
21	Plate Assembly	All	10457300
22	On-Off Switch	All	R0099800
23	Temperature Control Label	All	H0105300
24	Temperature Sensor	All	R0011800
25	Protector Sleeve, Bulb	All	10444900
26	"O" Ring, Temperature Control Bulb	All	E0116400
27	Thermostat Knob, Black	All	R0010700
28	Stop Plate, "Temp-Lok"	All	10583100
29	Temperature Control Gasket	All	S0070000
30	Bezel	All	S0069800
31	Stop Plate Screw (Not Shown)	All	F0033300
32	Temperature Sensor Retainer Bracket	All	10447300
33	Retainer Bracket Screw	All	F0009100
34	Pressure Switch & Siphon Loop Assembly (2 PSI)	All	R0097600
35	Pressure Switch, 2 PSI	All	R0013200
35	Pressure Switch, 1 PSI	All	R0011300
35	Pressure Switch, 1-10 PSI	All	R0015500
36	Siphon Loop Assembly	All	R0057800
37	High-Limit Switch Assembly	All	R0023200
38	High-Limit Switch, 135° F	All	R0022700
39	High-Limit Switch, 150° F	All	R0023000
40	High-Limit Switch Retainer Boot	All	S0098900
41	High-Limit Switch Wire Harness	All	10419300
42	High-Limit Switch Retainer Clip	All	10418400
43	High-Limit Switch Cover	All	10418300
44	Fusible Link Assembly	All	R0012200
45	Fusible Link Bracket	All	10479900
46	Terminal Block	All	R0097800
VENT SYSTEM			
47	Top Enclosure	125-400	R0343401-05
48	Top Filler Plate	125-400	R0343701-05
49	Rainshield Kit	125-400	R0318301-05
50	Flue Collector Assembly	125-400	R0316401-05
51	Outdoor Vent Cap	125-400	10561501-05
52	Indoor Drafthood	125-400	10561401-05
53	Flue Transition Plate	125-400	10861901-05
54	Adapter Plate	125-400	10535301-05
55	Clip	All	10211000
56	Flue Collector Hold Down Clamp	All	10726000
WATER SYSTEM			
57	Inlet/Outlet Header, 2"	All	R0056400
57	Inlet/Outlet Header, Bronze, 2"	All	R0016800
58	Return Header (Includes set of 9 gaskets)	All	R0058300
58	Return Header, Bronze (Includes set of 9 gaskets)	All	R0054600
59	Header Bolt Assembly (Set of 8)	All	R0057000
60	Bolt for Headers, 2 1/2"	All	F0046100
61	Washer for Headers	All	F0011100
62	Nut for Headers	All	F0003100
63	Header Gasket Assembly (Set of 18)	All	R0050800
64	Flange & Gasket Assembly (Set of 2)	All	R0055000
65	Flange, 2"	All	10573500
66	Flange Gasket, 2"	All	S0078000
67	Flange Sleeve, 2"	All	S0078200
68	Flange Bolt	All	F0031700
69	Flange Gasket, 1 1/2 - 2"	All	S0078100
70	Rubber Grommet for Drain Plug	All	R0316300
71	Grommet, Slitted (Not Shown)	All	S0071100
72	Brass Connector Body	All	P0019701
73	Brass Drain Plug 1/4"	All	P0026800
74	Brass Plug, 3/4"	All	P0027000
75	By-Pass Assembly w/o spring (Iron Cap)	All	R0013100
75	By-Pass Assembly with spring (Bronze Cap)	125-400	10701401-05
76	By-Pass Valve Rod	All	S0079800

Key No	Description	Model No	Order Part No.
WATER SYSTEM((Continued))			
77	Brass Nut (For Rod)	All	F0048400
78	By-Pass Valve Disc	All	R0011500
79	By-Pass Valve Control Cap (Iron)	All	10452200
79	By-Pass Valve Control Cap (Bronze)	All	10557400
80	Control Cap Bolts (2 Required)	All	F0041600
81	By-Pass Valve Spring, Purple	125	S0079900
81	By-Pass Valve Spring, White	175	S0061400
81	By-Pass Valve Spring, Red	250	S0061300
81	By-Pass Valve Spring, Blue	325	S0061200
81	By-Pass Valve Spring, Black	400	S0070100
82	By-Pass Valve Gasket	All	R0011400
83	Heat Exch. Tube Assy. (Incl. set of 18 gaskets)	125-400	R0018101-05
84	Heat Exchanger Baffle (8 Required)	125-400	10697401-05
85	Baffle Retainer	All	S0083900
86	Heat Exchanger Support Clip (2 Required)	All	10457000
87	Flow Restrictors (2 Required) (Not Shown)	125	S0000300
88	Heat Exchanger End Baffles (2 Required)	125-400	R0332301-05
FIREBOX COMPONENTS			
89	Complete Combustion Chamber Assy.	125-400	R0316701-05
JACKET COMPONENTS			
90	Door with Latch	125-400	R0343601-05
91	Jacket Assembly, Less Top Assembly	125-400	R0343501-05
92	Gap Closure, Inlet/Outlet	All	R0344300
93	Gap Closure, Return	All	R0344400
94	Button Plug, 1-3/4"	All	F0035300
95	Button Plug, 7/8"	All	F0032300
96	Button Plug, 2" (With hole for gas line)	All	F0056600
OPTIONAL COMPONENTS			
	Non Combustible Base	125-400	10521701-05
	Pressure Relief Valve 3/4" NPT, 75 PSI	All	R0040400
	Touch Up Spray Paint, Pewter	All	X0022700
	Touch Up Spray Paint, Black	All	X0022900

Notes:

1. For altitudes 2,000 Ft above sea level, call factory for orifice size.
2. For altitudes 5,000 Ft above sea level, call factory for orifice size.

11.3 General Exploded View

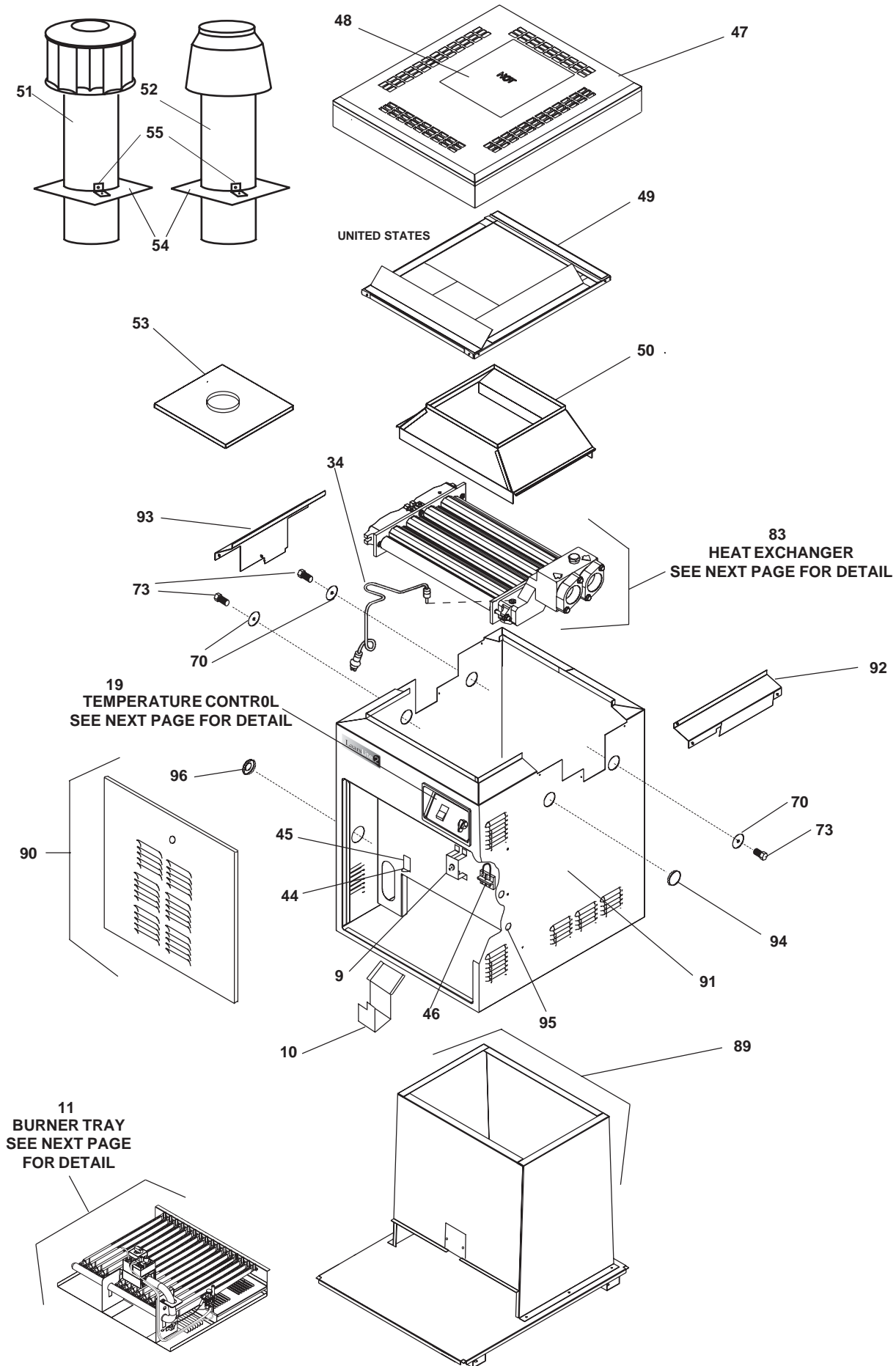

11.4 Detailed Exploded View

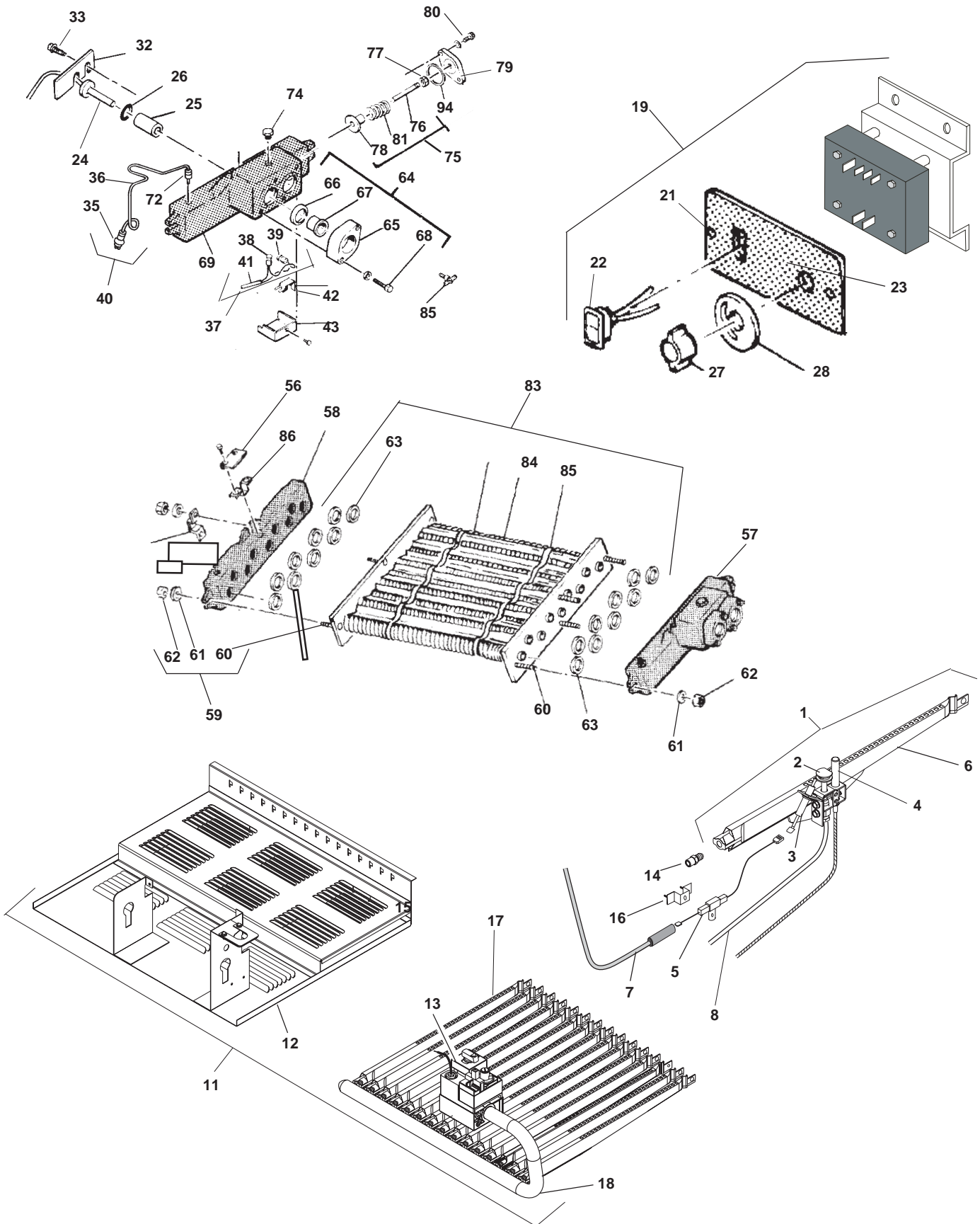

LIMITED WARRANTY

Thank you for purchasing Jandy® pool and spa products. Water Pik Technologies (manufacturer of Jandy products) warrants all parts to be free from manufacturing defects in materials and workmanship for a period of one year from the date of retail purchase, with the following exceptions:

- AquaLink® RS units installed with Jandy Surge Protection Kits will be covered for two years.
- NeverLube® valves are warranted for the life of pool and/or spa on which they were originally installed.

This warranty is limited to the first retail purchaser, is not transferable, and does not apply to products that have been moved from their original installation sites. The liability of Water Pik Technologies shall not exceed the repair or replacement of defective parts and does not include any costs for labor to remove and reinstall the defective part, transportation to or from the factory, and any other materials required to make the repair. This warranty does not cover failures or malfunctions resulting from the following:

1. Failure to properly install, operate or maintain the product(s) in accordance with our published Installation, Operation and Maintenance Manuals provided with the product(s).
2. The workmanship of any installer of the product(s).
3. Not maintaining a proper chemical balance in your pool and/or spa [pH level between 7.2 and 7.8, Total Alkalinity (TA) between 80 to 120 ppm, Total Dissolved Solids (TDS) less than 2000].
4. Abuse, alteration, accident, fire, flood, lightning, rodents, insects, negligence or acts of God.
5. Scaling, freezing, or other conditions causing inadequate water circulation.
6. Operating the product(s) at water flow rates outside the published minimum and maximum specifications.
7. Use of non-factory authorized parts or accessories in conjunction with the product(s).
8. Chemical contamination of combustion air or improper use of sanitizing chemicals, such as introducing sanitizing chemicals upstream of the heater and cleaner hose or through the skimmer.
9. Overheating, incorrect wire runs; improper electrical supply; collateral damage caused by failure of O-Rings, DE grids, or cartridge elements; or damage caused by running the pump with insufficient quantities of water.

LIMITATION OF LIABILITY:

This is the only warranty given by Water Pik Technologies. No one is authorized to make any other warranties on Water Pik Technologies' behalf. **THIS WARRANTY IS IN LIEU OF ALL OTHER WARRANTIES, EXPRESSED OR IMPLIED, INCLUDING BUT NOT LIMITED TO ANY IMPLIED WARRANTIES OF FITNESS FOR A PARTICULAR PURPOSE AND MERCHANTABILITY. WATER PIK TECHNOLOGIES EXPRESSLY DISCLAIMS AND EXCLUDES ANY LIABILITY FOR CONSEQUENTIAL, INCIDENTAL, INDIRECT OR PUNITIVE DAMAGES FOR BREACH OF ANY EXPRESSED OR IMPLIED WARRANTY.** This warranty gives you specific legal rights. You may also have other rights which vary by state or province.

WARRANTY CLAIMS:

For prompt warranty consideration, contact your dealer and provide the following information: proof of purchase, model number, serial number and date of installation. The installer will contact the factory for instructions regarding the claim and to determine the location of the nearest designated service center. If the dealer is not available, you can locate a service center in your area by visiting www.jandy.com or by calling our technical support department at (707) 776-8200 extension 260. All returned parts must have a Returned Material Authorization number to be evaluated under the terms of this warranty.

H0264600A

Jandy®



6000 Condor Drive, Moorpark, CA, USA 93021 • 707.776.8200 FAX 707.763.7785

A Water Pik Technologies Company

Litho in U.S.A. © Water Pik Technologies Inc. 0506