

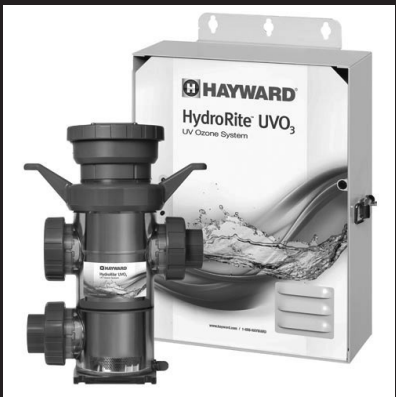

HydroRite UVO₃

2" Residential UV/Ozone Water Treatment System

Owner's Manual



The image shows the HydroRite UVO₃ UV/Ozone System. On the left is the physical unit, a cylindrical black device with various ports and a top cap. On the right is the retail box, which is white and features the Hayward logo and product name. The box also has an image of water splashing.

Contents	
Safety Instructions.....	1
Before you Begin.....	2
Installation.....	3
Operation.....	7
Maintenance.....	7
FAQs.....	10
Troubleshooting.....	11
Replacement Parts.....	12
Warranty.....	14

Model: HYD-UVO-CUL

Hayward Pool Products Canada
2880 Plymouth Drive, Oakville, ON L6H 5R4
Phone 1.888.238.7665
Haywardpool.ca



HAYWARD®

IMPORTANT SAFETY INSTRUCTIONS

When installing and using this electrical equipment, basic safety precautions should always be followed, including the following:

READ AND FOLLOW ALL INSTRUCTIONS

This product should be installed by a professional service technician or similar person who is qualified in electrical equipment installation. Improper installation and/or operation could cause serious personal injury, property damage or death. Improper installation and/or operation will void the warranty.

- The device must be connected only to a supply circuit that is protected by a Ground Fault Circuit Interrupter (GFCI). FAILURE TO CONNECT THIS DEVICE TO A GFCI SUPPLY CIRCUIT COULD RESULT IN ELECTRICAL SHOCK CAUSING SERIOUS BODILY INJURY, INCLUDING DEATH.
- WARNING - Disconnect all AC power during installation.
- CAUTION - To prevent possible fire or electrical shock, use only replacement lamp specified by the manufacturer.
- A bonding lug is provided on the external surface. To reduce the risk of electric shock, connect the local common bonding grid in the area of the swimming pool, spa, or hot tub to these terminals with an insulated or bare copper conductor not smaller than 8 AWG US / 6 AWG Canada.
- Replace damaged cords immediately.
- Lamps and quartz sleeves are made of glass and are extremely delicate. Care should be taken when handling or replacing these components. Wear cotton gloves when handling lamps or sleeves. Hold bulbs by the ends only. Never touch the glass with bare hands. Wipe any fingerprints from lamps and sleeves with alcohol.
- CAUTION - this device is for swimming pool use only. Do not use this device for potable (drinking) water sanitization.
- DANGER - ULTRAVIOLET RADIATION. Disconnect Power Before Replacing Lamp .
- This device contains an ultraviolet lamp that can cause discomfort, irritation and damage to the eyes if viewing occurs while device is in operation. Prolonged exposure to the eyes can cause serious injury to the eyes, including blindness. DO NOT VIEW UV LAMP WHILE THE DEVICE IS IN OPERATION.
- **SAVE THESE INSTRUCTIONS**



Before you Begin

The Hayward HydroRite™ HYD-UVO-CUL is designed for use in residential swimming pools and spas; it must not be used in potable (drinking) water installations. Use of this product in applications other than swimming pools and spas will void your warranty and could be harmful to your health or the health of others.

How the Hayward HydroRite Works

The Hayward HydroRite contains a high intensity electrically operated Ultraviolet (UV) lamp which is located inside the unit's wet chamber. The UV lamp emits light at two separate wavelengths within the UV spectrum; 254 nm and 185 nm suitable for optimal water treatment when used in conjunction with a Chlorine or Bromine residual as required under local Health Department regulations. The 185 nm wavelength, is called the "ozone generating" wavelength and is responsible for converting oxygen contained in the quartz sleeve area, into ozone. The ozone so created is introduced into the water stream using a venturi and associated booster pump. Ozone, a strong oxidizer and bactericide, works together with the UV to oxidize bather waste utilizing a process known as "advanced-oxidation". When the HydroRite is creating Ozone, bubbles will appear within the HydroRite vessel and may also be seen at the return jets in the pool. At flow rates below 35 gpm, Ozone creation will stop and the bubbles will disappear. Although low flow rates will prevent the creation of ozone, the longer exposure time to UV light within the vessel will increase the efficiency and efficacy of the UV water treatment process.

When the HydroRite is creating Ozone, bubbles will appear within the HydroRite vessel and may also be seen at the return jets in the pool. At flow rates below 35 gpm, Ozone creation will stop and the bubbles will disappear. Although low flow rates will prevent the creation of ozone, the longer exposure time to UV light within the vessel will increase the efficiency and efficacy of the UV sanitization process. Consider these factors when setting run times and pump speeds.

Specifications

HYD-UVO-CUL

Plumbing diameter: 2 inch
Input Power: 120VAC, 60Hz
Power Consumption: 0.8A
Maximum Operating Pressure: 50 psi
Operating Flow Range: 10-75 gpm
Minimum Flow Rate of Venturi (necessary for the creation of ozone): 35gpm
Maximum Flow Rate: 75 gpm
Number of bulbs: 1
Volume of Vessel: 0.75 gallon

Sizing

The HydroRite HYD-UVO-CUL is capable of sanitizing residential pools up to 60,000 gallons. For larger installations, more than one HydroRite can be used. When using multiple HydroRites, plumb vessels in parallel.

WARNING: Determine that the flow rate of your pool does not exceed the maximum specified.

What's Included

The HydroRite system contains the following components:

- HydroRite Controller
- Vessel
- 2" Venturi Manifold
- Venturi Hose Kit with check valves and fittings
- Ozone Producing UV Lamp
- Gloves for handling the UV Lamp
- 2" Flow Switch
- 2" 3-Way Valve
- Valve Actuator

Tools Needed

- Saw or PVC pipe cutter
- PVC glue
- 6 mounting screws/bolts for fastening HydroRite controller to mounting surface
- 4 mounting screws/bolts for fastening HydroRite vessel to mounting surface
- Screwdriver/Nutdriver for mounting fasteners
- Philips head screwdriver for vessel cap

Installation

Before starting your installation, you **MUST** read this manual in its entirety in order to install your unit in a safe manner. Note that a few moments spent becoming familiar with the HydroRite unit and its installation may save a great deal of time (and expense) later. If you have any questions that are unanswered when you have completed the reading of this manual, contact your supplier or Hayward.

Overview

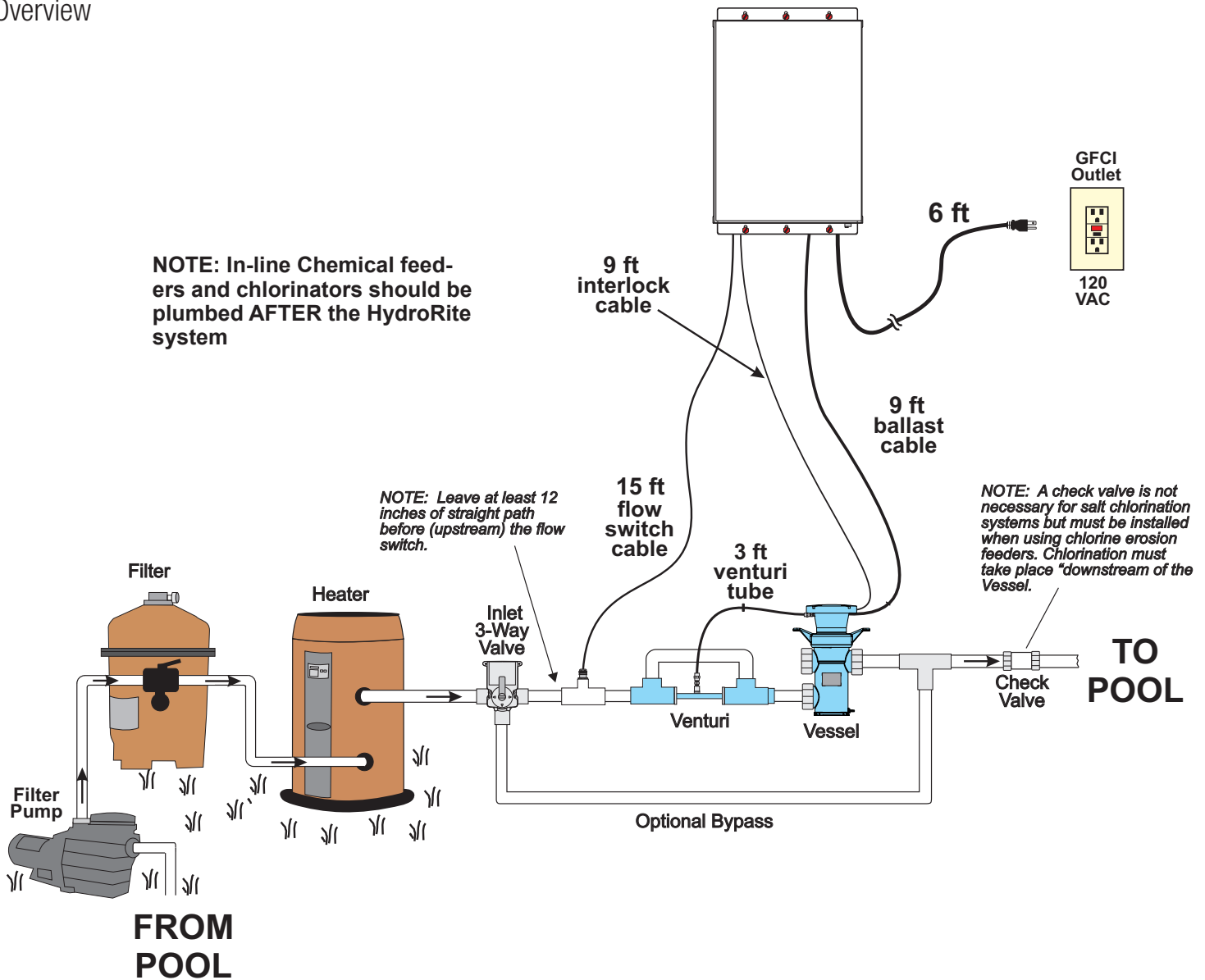

Determine a suitable location

Installation of HydroRite system requires mounting the controller and vessel, plumbing the vessel, venturi and flow switch (on the return side of the filter pump), and finally, connecting the required cables. Remove power to the pool filter pump before starting this installation. Installation must be performed in accordance with local and NEC code.

The HydroRite vessel must be mounted at least 10 ft. from the pool. The controller must be mounted a minimum of 6 ft. horizontal distance (or more, if local codes require) from the pool and has a 6 ft. power cord that must be connected to a GFCI protected circuit. Refer to the diagram above for lengths of other cords and the venturi tube. Note that the vessel and flow switch will be plumbed into the return plumbing after the heater and all other equipment with the exception of chemical feeders and chlorination systems.



Mounting the Controller

The controller is designed to mount vertically on a flat surface with the cables facing downward. Because the enclosure also acts as a heat sink (disperses heat from inside the box), it is important not to block the four sides of the controller. Do not mount the controller inside a panel or tightly enclosed area. If the supply or a lamp cord is damaged, it must be replaced by the manufacturer, its service agent or similarly qualified persons in order to avoid a hazard.

After ensuring that the controller's cables can reach their destinations, mount the controller to the intended surface using proper mounting hardware given the size and weight of the unit. The controller's mounting brackets require a total of 6 mounting bolts to fasten the controller to the mounting surface.

Plumbing the HydroRite System

Note that the Hydrorite system will impose additional head loss to the pool's circulation system. As such, Hayward recommends that the HydroRite system be plumbed in a manner (see diagram on page 3) that allows the unit to be bypassed under high flow conditions. It is expected that high flow conditions would be encountered when utilizing the jets of a spa, or operating a suction cleaner or activating a water feature, as a few examples. In these high flow situations, a valve and actuator (included with the product) can be used to bypass the Hydrorite system to avoid the added head loss. Be aware that the Hydrorite will not be sanitizing the water when the bypass mode is used.

When using automation systems such as Hayward's Omnilogic or Prologic systems, the valve/actuator can be made to be part of a group or theme setting so that the valve will turn and allow the bypass of the Hydrorite system under the conditions where high flow is used. Note that lower flow rates are always better for energy savings and filtration performance.

When installing the HydroRite below the waterline, 3-way valves on the inlet and outlet lines to the vessel are mandatory. Failure to use valves where any portion of the device is below the waterline will not allow the device to be properly drained which could lead to cracking of the unit if any retained water freezes.

Securing the Vessel

When the vessel installation location has been determined, it should be secured to a concrete or wood base. Four mounting holes are located in the mounting base of the unit that accommodates 1/4 inch diameter bolts to mount the HydroRite unit in place. FAILURE TO PROPERLY SECURE THE UNIT MAY CAUSE NOISE DUE TO VIBRATION CAUSED BY WATER PASSING THROUGH THE WET CHAMBER. Secure the vessel using bolts and anchors (not supplied) where necessary and appropriate for your installation.

Plumbing the Vessel

The HydroRite vessel comes with union nuts and tails pre-assembled on the housing. Remove the Inlet and Outlet nuts and note the orientation of the orange gaskets when removing union tails. These will need to be put back together after gluing the union tails to the pool piping.

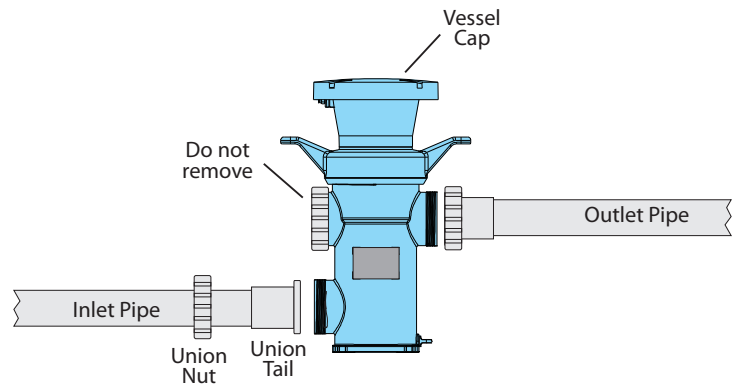

After cutting pipe to length, slide one union nut onto the cut pipe and glue the gray tail piece to the pipe end. Repeat for the other pipe. Thread the union nuts onto the vessel and handtighten both unions. DO NOT OVERTIGHTEN. OVERTIGHTENING WILL BREAK THE UNION NUTS. To avoid stress on the connections at the vessel, piping should be supported and should not rest solely upon the unions.

Plumbing the Flow Switch

The flow switch is a safety device that ensures that the HydroRite is only operating when there is water passing through the vessel. The flow switch must be plumbed in the same section of plumbing as the vessel. Failure to properly install the flow switch can result in damage to the pool's equipment.

IMPORTANT: There must be at least a 12" (30cm) straight pipe run before (upstream) the flow switch.

IMPORTANT: To ensure proper operation, verify that the arrow on the flow switch points in the direction of water flow.

Head Loss

Refer to the adjacent table below for Head Loss information.

Venturi

The venturi assembly is pre-assembled and ready to be plumbed. A 3 ft hose connection is made from the venturi to the ozone manifold at the vessel as shown in the diagram on page 3. More information about the venturi tube and connection can be found on page 5.

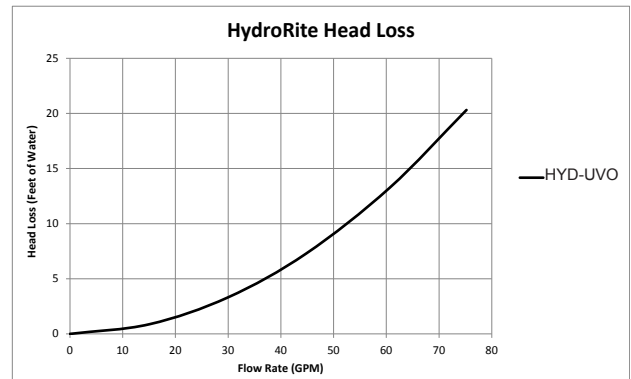

Chlorination Systems

Care must be taken to prevent exposure of the vessel to high concentrations of chlorine. All in-line chlorine systems must be installed AFTER (downstream) the vessel.

If using a chlorine erosion feeder or other chemical feeders, install a check valve (see diagram on page 3) to isolate the vessel from the feeder, preventing chlorine from backfeeding when the pump is off. For salt chlorinators, a check valve is not necessary because those systems stop producing chlorine when the pump is off.

After plumbing is complete, run the filter pump and check for leaks in the HydroRite loop and the bypass loop. Address any concerns before making electrical connections.

Electrical Connections

Do not plug in the electrical power cord until all wiring is complete.

There are 2 wiring connections between the controller and the HydroRite vessel. In addition, a connection must be made at the controller from the flow switch.

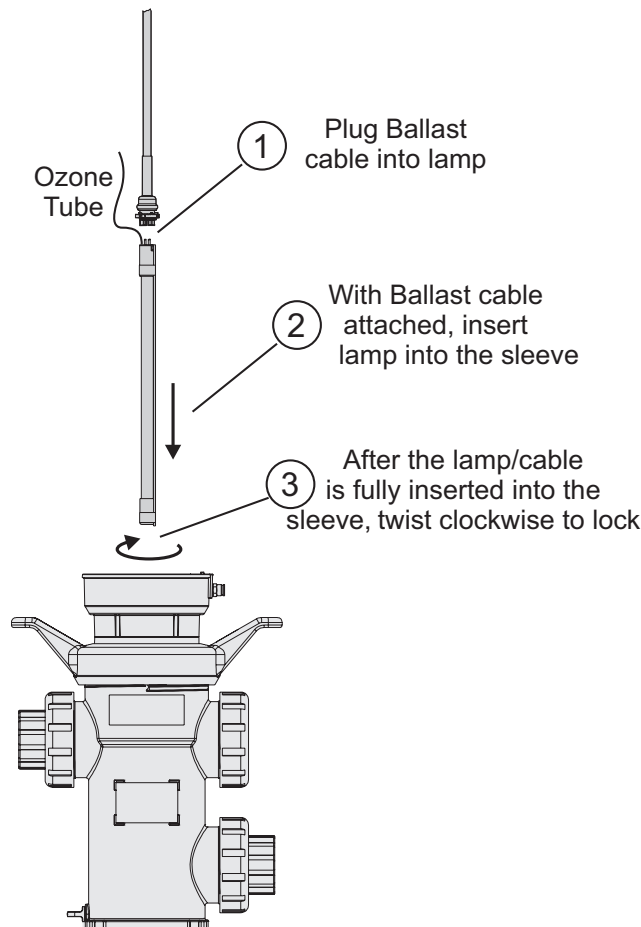
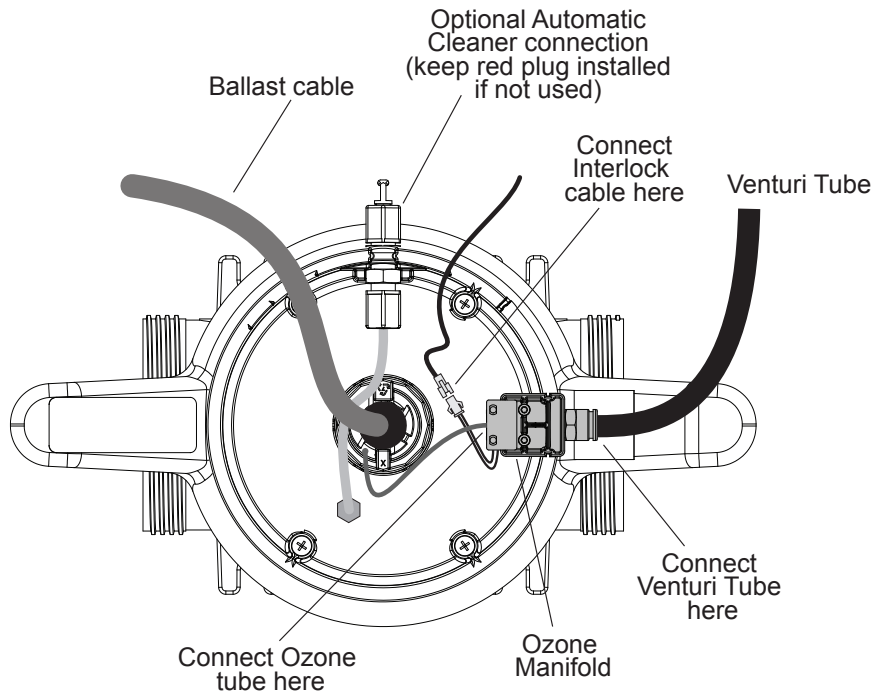

Vessel Connections

To gain access to connectors, remove the four screws securing the large vessel cap (cover). Remove the cap. Make your connections and route the cables through an appropriately sized cutout. The cap can then be replaced and secured. Refer to the information below and the diagrams on this page for connection locations.

Venturi Tube

Insert the 3 ft. venturi tube into the ozone manifold as shown above. Note that the tube can be cut to a shorter length to aid in installation. To avoid leaks, be sure to make a clean square cut so that the tube fits into the ozone manifold properly.

The venturi tube is made of a specific material suitable for its purpose. If replacing the tube or if a longer tube is needed, call Hayward Technical Support at 908-355-7995.

Ballast Cable and UV Lamp

DO NOT TOUCH THE UV LAMP WITH YOUR BARE HANDS. Gloves are included with HydroRite and must be used when handling the lamp. There is a single ballast cable from the controller that connects to the UV lamp (packaged separately). This cable must be connected to the lamp BEFORE inserting the lamp into the vessel. Because of the different size tabs on the lamp, it will only insert one way into the vessel. After fully seating the lamp into the vessel, twist the lamp/cable clockwise about 1/8 turn to lock it into place. Route the ballast cable through the appropriate cutout.

Ozone Tube

Insert the UV lamp's ozone tube into the back of the ozone manifold as shown above. Note that the ozone tube can be cut to a shorter length for easier routing.

Interlock Cable

The Interlock prevents lamp operation when the cap is removed. The two conductor interlock cable attaches to the square connector at the end of the pigtail shown above. Find the appropriate cutout and route the wire through.

Replace Vessel Cap

After making the above connections and routing the cables through the proper cutouts, replace and fasten the cap.



Controller Connections

Flow Switch and Interlock Cable

Refer to the diagram below. The flow switch and interlock cables both use an RJ-11 connector that plug into the bottom of the HydroRite controller. The connectors are not labeled and either connector can be used.

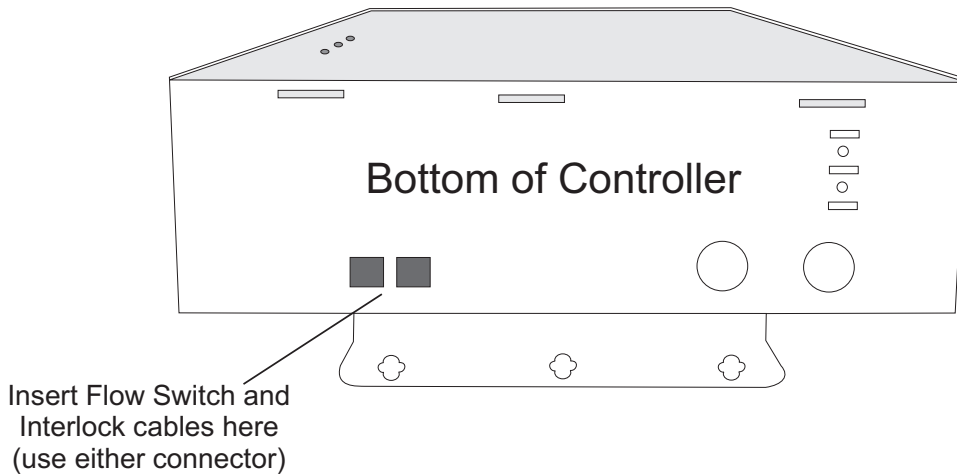

Input Power

HydroRite uses a linecord for input power and must be plugged into a 120V 50/60hz GFCI protected outlet. NOTE: Should the electrical power cord of your HydroRite unit become frayed or damaged, unplug it from the power receptacle and contact Hayward. USE OF A FRAYED OR DAMAGED POWER CORD COULD RESULT IN ELECTRICAL SHOCK CAUSING SERIOUS BODILY INJURY, INCLUDING DEATH.

Pool Preparation

Water Preparation

Now that HydroRite has been plumbed and wired, start the pool pump and verify that there are no leaks at the vessel. Before starting operation of HydroRite, the pool's chemistry should be checked and adjusted to the recommended levels shown below. If opening the pool for the first time of the season, sanitize and balance the pool BEFORE operating HydroRite.

NOTE: UV light, whether from HydroRite or the sun, will deplete the pool's chlorine over time. It's important to maintain the proper level of Cyanuric Acid (Stabilizer) to prevent this reaction. Use the recommended level of Cyanuric Acid regardless of whether it is indoors or outdoors.

CHEMICAL	IDEAL LEVELS
Free Chlorine	1.0 - 3.0 ppm
Cyanuric Acid	30 to 50 ppm
pH	7.2 to 7.8
Total Alkalinity	80 to 120 ppm
Calcium Hardness	200 to 400 ppm
Iron	<0.3 ppm (0.3 mg/L)
Manganese	<0.05 ppm (0.05 mg/L)

Operation

Start Up and Operation

With the pool water balanced and the installation complete, HydroRite can be plugged into a GFCI protected outlet to begin operation. After powering up, the UV lamp inside of the vessel will illuminate and the green POWER ON LED on the controller should be lit. HydroRite's operation is fully automatic and requires no interaction from the user. It is designed to stay powered and active at all times and will stop sanitizing when it senses that the pool pump has turned off. When the pool water flow returns, HydroRite will automatically resume operation.

LED Indicators

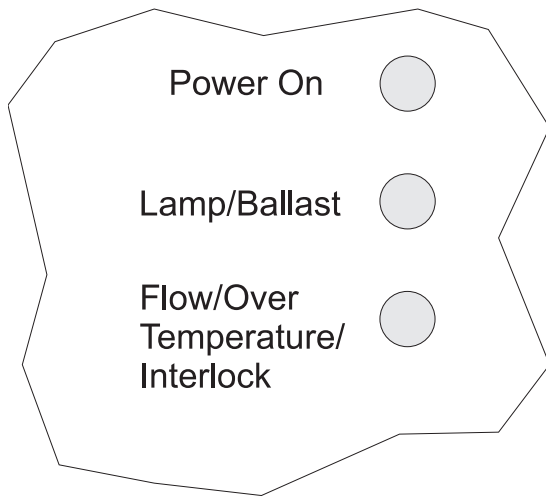

Power On LED

This green LED will be on under normal operation. Even when the pool pump is not running and HydroRite shuts off its lamp, the Power On LED will be lit.

Lamp/Ballast LED

This red LED indicator will come on when there is an issue with the lamp or ballast. It will also light if there is a problem with the connection from the ballast cable to the lamp. Note that the lamp has a defined life and will eventually need to be replaced. Refer to Maintenance and the UV Lamp Replacement sections of this manual for more information.

Flow/Over Temperature/Interlock LED

The HydroRite will shut down due to the following conditions:

- *Flow* - the LED will light when the HydroRite sense a no-flow condition. This will happen normally whenever the pool filter pump is turned off and the pool water stops flowing.
- *Over Temperature* - The HydroRite has a temperature sensor inside its enclosure and will shut down operation to protect itself if it senses very high temperatures. Note that high ambient temperatures and direct sunshine can contribute to an over temperature condition.
- *Interlock* - The LED will light indicating that the vessel cap has not been installed properly or the interlock connection is not properly made.

Maintenance

HydroRite has been designed for robust performance in the harsh environmental conditions of sun, wind, and rain. Like most pool equipment, routine maintenance will help provide years of trouble-free service. While HydroRite requires very little maintenance throughout the year, inorganic and organic chemicals may deposit on the surface of the quartz sleeve causing it to appear hazy/foggy and reducing its efficacy by lowering the germicidal UV (254nm wavelength light) transmittance. Cleaning the sleeve should return HydroRite to previous performance.

Hayward recommends that you remove the lamp and clean the sleeve every 1-3 months depending on the condition of your pool's water. The sleeve may need more frequent cleaning in areas of the country that have hard water. The quartz sleeve can be manually cleaned or cleaned with an in-line automatic cleaner.

Automatic Cleaning of the Quartz Sleeve

When using an automatic cleaner, the HydroRite's quartz sleeve can be cleaned with no need to disassemble the vessel. When the user initiates a cleaning, an acid bath will clean the quartz sleeve. The cleaner is connected to the inlet and outlet ports located on the top and bottom sides of the vessel only when cleaning, then disconnected during normal operation. If automatic cleaning will be employed, three way valves are required to isolate the HydroRite vessel from the pool's plumbing. Refer to your automatic cleaner for cleaning instructions.

Muriatic Acid: Use a diluted mixture of 4 parts water to 1 part Muriatic acid (20° Baume hydrochloric acid 31.45% by weight). Always add acid to water, and do so slowly.

Disposing of Acid

Follow the manufacturer's instructions on how to properly dispose of the Muriatic Acid mixture.

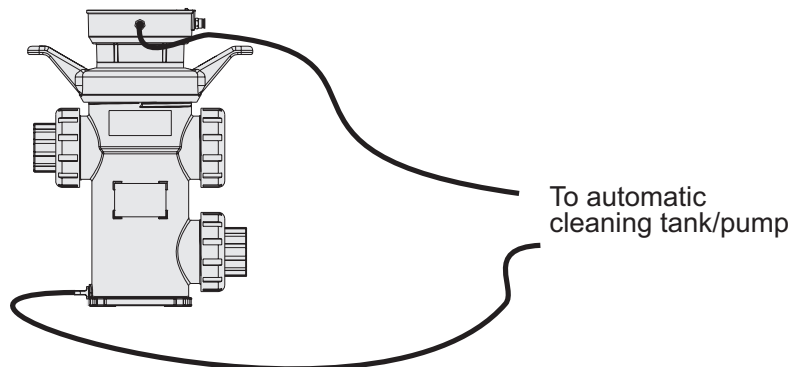



Manual Cleaning of the Quartz Sleeve

To remove and clean the quartz sleeve, follow the steps shown below:

CAUTION: The UV lamp is sensitive to handling and should be allowed to fully cool before being moved. Wait at least 30 minutes after disconnecting power to begin the removal process.

1. Disconnect Power

Unplug the device from its Power Outlet.

2. Stop the Circulation Pump

You must shut off the circulation pump so that no water is flowing into the vessel. When you are absolutely sure that there remains no pressure inside the HydroRite vessel, you can proceed to the next step.

3. Drain the HydroRite System

You must drain the unit before any internal maintenance is performed. To drain, unscrew the threaded plug from the base of the vessel. **NOTE:** If the Acid Wash system is plumbed, remove the hose to the shut-off valve from the base of the vessel. You can then open the valve to release the pool water.

4. Remove the Electrical Enclosure Cover

NEVER REMOVE THE VESSEL CAP WITHOUT FIRST UNPLUGGING THE CONTROLLER FROM ITS POWER SOURCE – DO NOT OPERATE THE UNIT WITH THE CAP REMOVED - The vessel cap is removed by unscrewing the four mounting screws that hold the cap to the HydroRite vessel.

5. Remove the UV Lamp

To remove the lamp, grasp the lamp connector (at end of ballast cable) and rotate counter-clockwise (about 1/8 turn) to unlock the lamp from the vessel. Once unlocked, slowly pull the lamp straight up and away from the quartz sleeve until it clears the vessel. **DO NOT TOUCH THE UV LAMP WITH YOUR BARE HANDS!** Oils from your hands can attach to the lamp surface and create hot spots during operation and shorten lamp life. Use a soft clean cotton cloth (or cotton gloves) to handle the lamp. Carefully place the lamp in a safe location.

NOTE: If you should touch the lamp with your bare hands, it can be cleaned with a soft cotton cloth and rubbing alcohol

6. Unscrew the Vessel Lock Nut

Grasp the two large “handles” on the vessel lock nut and fully unscrew (counterclockwise) the light engine.

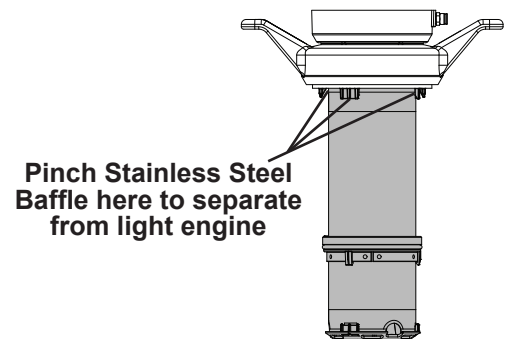
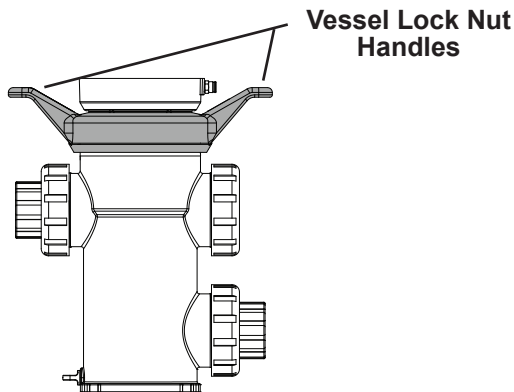

7. Pull the Light Engine out of the Vessel

Using the handles on the vessel lock nut, lift the light engine straight up and out of the vessel.

8. Remove the Stainless Steel Baffle

There is a stainless steel baffle that surrounds the quartz sleeve which must be removed. To remove the baffle, pinch the end in three places while pulling it away from the light engine (see adjacent diagram). Pinching the baffle at those points will flex the surface enough to “unhook” itself from the light engine.

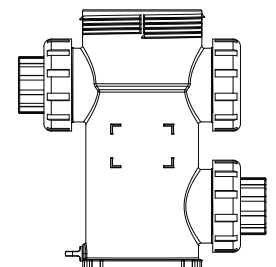



HAYWARD®

9. Cleaning the Quartz Sleeve

The quartz sleeve will now be exposed and can be cleaned. Note that the inside of the glass sleeve is normally sealed and should never need cleaning. Carefully clean the outside of the quartz sleeve using NON-ABRASIVE CLEANERS, as they can scratch the high quality glass. If lime or hard water calcium deposits are encountered, rinse the quartz sleeve with tap water, then clean with lime removal products such as Lime-A-Way® or a Muriatic acid mixture as described on page 7. Use appropriate eye protection and gloves when handling harsh chemicals. A lint free cloth can be used to help wipe away deposits. After using the lime removal products, rinse and wipe with the sleeve with Isopropyl alcohol. Completely dry the sleeve before re-assembly.

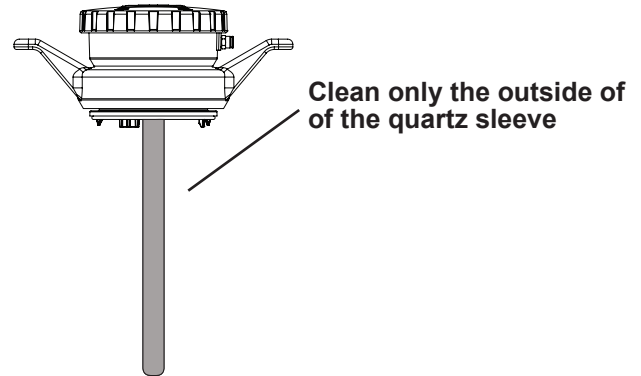

Carefully inspect the cleaned quartz sleeve for cracks. If any cracks in the quartz sleeve are found, the sleeve should be replaced. A broken quartz sleeve will allow water to enter the dry electrical chamber and attack the electrical components of the unit, which will cause them to fail and need to be replaced. Dispose of any broken glass in the proper waste receptacle. BROKEN QUARTZ SLEEVES, OR WATER DAMAGE CAUSED BY BROKEN QUARTZ SLEEVES, ARE NOT COVERED UNDER YOUR LIMITED WARRANTY.

10. Reinstall the Stainless Steel Baffle

The easiest way to reinstall the baffle is to place it end up on the ground and lower the light engine on top of it. Guide the baffle making sure that the 3 locking tabs on the light engine line up with the 3 slots in the baffle. Gently push the light engine down until the baffle snaps into place.

11. Insert the Light Engine into the Vessel and Fasten with the Vessel Lock Nut

The light engine must be oriented in a certain position for it to fully insert into the vessel. Lower the light engine until the final 1" or so and look for the two slots on the inside top of the vessel. Spin the light engine until the two keys line up with the slots. Now fully push the light engine down into the vessel and lock by tightening the vessel lock nut.

12. Reinstall the UV lamp.

Slowly lower the lamp down into the quartz sleeve and twist clockwise to lock.

13. Reinstall the Vessel Cap

Place the vessel cap on the top of the HydroRite unit and tighten the screws using a Phillips screwdriver. DO NOT over tighten the screws due to risk of cracking the cover. Turn on the circulation pump, making sure to open any valves (if applicable) that were closed. Verify that there are no leaks before powering the HydroRite.

Scheduled UV Lamp Replacement

In addition to cleaning of the quartz sleeve, periodic replacement of the UV lamp is required. The High Output UV lamp in your HydroRite unit is designed to last for approximately 13,000 hours of continuous operation. If replacing the lamp, clean the quartz sleeve at the same time to minimize your maintenance efforts.

Winterizing

Your HydroRite unit can be damaged if not properly winterized. Ice formation inside the vessel can break the glass quartz sleeve, the UV lamp or the vessel itself. Therefore, you must protect your HydroRite unit from freezing. Damage due to freezing, including the breakage of glass components, the vessel, or water damage to other components caused by freezing IS NOT COVERED under your Limited Warranty. During winterization, drain your UV device of all water within the vessel—use a Wet-Dry vacuum if necessary. Store the sleeve and lamp and all connectors in a manner to prevent breakage or corrosion during the winter months.

Freeze damage

Freeze damage can be avoided by keeping the water flowing at a minimum of 5 PSI pressure at all times, without interruption during freezing weather. All pump timers must be inoperable and the pump must run continuously. Freeze damage can also be avoided if the pump and HydroRite unit are maintained inside a climate controlled enclosure. If you do not plan to operate your HydroRite unit during freezing temperatures, you must take precautions to make sure all water is removed from inside the HydroRite vessel so it does not freeze. This can be accomplished by first closing any valves on lines in the plumbing system and then opening the inlet union at the bottom of the HydroRite unit so that the water can drain.

How To Obtain Service

In the event that service is required, contact your builder or dealer so they can advise the best method of providing the services you need. In some instances, the supplier will handle the required service themselves, including the ability to supply any necessary parts. In other instances, the supplier will refer you to Hayward, who can assist you as well. Please read the Limited Warranty in this manual for your HydroRite unit. It explains fully what is and what is not covered under the Limited Warranty and the warranty periods.



FAQs

- Q. *Is HydroRite compatible with ALL Pool chemicals?*
A. YES, except for a biguanide sanitizer. The strong oxidizing power of the HydroRite device will destroy the biguanide chemical, rendering the water a milky white color.
- Q. *Is There Any Residual Effect From UV?*
A. NO, UV light is applied only to the water while it passes through the HydroRite vessel. For this reason, a chemical sanitizer such as bromine or chlorine is still required.
- Q. *Is the HydroRite System Designed For Salt Water Use?*
A. YES, all plastic components are compatible with pools equipped with Hayward Salt Chlorine Generator Systems. Over time, the stainless steel baffle can be affected by a high salt environment but can be easily replaced if necessary.
- Q. *Do I Need To Turn HydroRite Off When I Clean My Filter?*
A. NO, the flow sensing pressure switch that is part of your HydroRite unit will automatically shut the UV lamp off until proper water flow inside the HydroRite vessel is re-established. Should you need to turn the HydroRite off, simply unplug the power cord from the power outlet.
- Q. *Will A Time Clock On My Pool Shorten My Lamp Life?*
A. NO, not unless the HydroRite is cycled on and off multiple times per day. A single ON/OFF cycle per day is normal and should give you optimum lamp life (which is ~13,000 hours). Frequent on/off cycles should be avoided and for longer lamp life, allow at least 10 minutes rest before turning back on. For best lamp efficiency, the lamp should be replaced on a yearly basis.
- Q. *Can the HydroRite Unit Be Mounted Horizontally?*
A. NO, vertical mounting is required to maintain the proper flow dynamics inside the vessel for maximum exposure to the UV light. Also, the unit has been designed for maximum weather integrity of the electronics when mounted vertically.
- Q. *Can Multiple Units Be Used Together For Larger Systems?*
A. YES, you can add any number of HydroRite units to a manifold system to allow for larger outputs and flow rates beyond the capacity of a single HydroRite unit. Contact Hayward to obtain a drawing showing the proper method of plumbing multiple HydroRites for larger applications.
- Q. *Is There Any Residual Effect From Ozone?*
A. NO, the Ozone create by the HydroRite is injected into the plumbing in front of the vessel. After entering the HydroRite vessel, the UV light converts the Ozone to Hydroxyl radicals in a process called Advanced Oxidation. The Hydroxyl radicals are very short lived oxidizers that are used up before the water exits the HydroRite vessel.
- Q. *Do I Still Need Chlorine?*
A. YES. HydroRite is a potent oxidizer but does not place a residual in the water. A residual (chlorine) is needed in the pool 24 hours per day to prevent algae buildup.



HAYWARD®

Troubleshooting

The information below will help guide you through any problems you may have at time of initial installation or during operation. For additional assistance, contact your supplier or Hayward.

The UV Lamp Will Not Light at Start-up

If this occurs upon initial start-up:

- Determine whether the Flow/Over Temperature/Interlock LED is lit. If so, resolve the issue.
- The lamp has become disconnected from the 4-pin connector. Disconnect the power cord from the electrical outlet, open the vessel cap and confirm the lamp connector is firmly in place. At the same time, check all exposed wires for a possible loose connection. Plug the electrical cord back into the electrical outlet ONLY after the electrical enclosure cover has been reinstalled on the unit.
- Verify that the power cord is plugged into a properly functioning electrical outlet. Test the electrical outlet and make sure the GFCI has not tripped. You should confirm the availability of the same voltage as indicted on the electrical label on your HydroRite unit.
- Make sure you have not plugged your device into any power source other than that specified on your device's electrical label. If you have done so in error, the ballast has been damaged and needs to be replaced. Contact your supplier or Hayward for the correct replacement ballast. A replacement ballast is not warranted.

The UV Lamp Is No Longer Lit

If this occurs after the unit has been operating successfully for a period of time:

- Determine whether the Flow/Over Temperature/Interlock LED is lit. If so, resolve the issue.
- The lamp has burned out. Replace the UV lamp.
- The ballast has burned out. Contact your supplier or Hayward for assistance in obtaining a new ballast.
- Verify that the electrical outlet where the device is plugged into has the proper voltage and the cord is securely plugged into the outlet.
- Verify that the GFCI has not tripped. To verify the operating state of the GFCI, trip the GFCI manually and reset it. The GFCI should reset. If it does not, it indicates a fault to ground in the electrical circuit or the HydroRite unit itself. Call a certified electrician to fix the problem.

The HydroRite Unit Makes Noise When Operating

If an unusual noise is heard from the vessel:

- The HydroRite vessel is not properly attached to a firm mounting base.
- The HydroRite vessel bottom plate may be cracked or damaged.

There is Water under the Vessel Cap

Water in contact with the electrical connectors can cause damage. If this occurs:

- The quartz sleeve seal is bad.
- There is a broken or cracked quartz sleeve.

There are no visible bubbles in the vessel

Bubbles seen in the vessel are an indication that Ozone is being generated. If no bubbles are seen, check the following:

- Flow rate through the venturi is too low (below 35 gpm).
- Venturi tube is not properly installed or seated.

Replacement Parts

Part Number	Description
GLX-HYDCTLUVO	Controller
GLX-HYDVESUVO	Vessel Body with Unions
GLX-HYDXFMR	Power Transformer
GLX-HYDPCB	Interconnect PCB
GLX-HYDFUSE	PCB Fuse Kit (QTY 10)
GLX-HYDBALLAST	Ballast with Cable Harnesses
HYXSLACA	UV Lamp Cable
HYXSFANA	Fan Assembly
GLX-HYDSLEEVE	Stainless Steel Sleeve With O-Rings
GLX-HYDMAN	Ozone Manifold and Interlock Switch
HYX2DQSA	Quartz Sleeve Assembly
GLX-HYD-LAMPUVO	Residential Lamp - Ozone Producing
GLX-HYDVEN	2" Venturi, Residential
HYX2DVTA	Venturi Ozone Tube Assembly Kit
ECX12S	2" PVC Pipe Connector Socket
ECX12T	2" PVC Pipe Connector Threaded
TBX122	2" PVC Union Nut
BSX1CAP2	2" PVC Port Cap
BSX1PLUG2	PVC Vessel Drain Plug
SB2KIT	Vessel O-Ring Kit
GVA-24	Valve Actuator
PSV3S2	3-Port Diverter Valve





HAYWARD® Pool Products Limited Warranty

To original purchasers of this equipment, Hayward Industries, Inc. warrants its HydroRite HYD-UVO-CUL to be free from defects in materials and workmanship for a period of Three (3) years from the date of purchase with the following exception. The UV lamp, UV lamp cable, quartz sleeve and stainless steel sleeve carry a One (1) year warranty from the date of purchase.

Part	Warranty Period	Coverage
Controller	3 Years	Parts only
Vessel	3 years	Parts only
UV Lamp	1 Year	Parts only
Quartz Sleeve	1 Year	Parts only
Stainless Steel Sleeve	1 Year	Parts only
UV Lamp Cable	1 Year	Parts only

The limited warranty excludes damage from freezing, negligence, improper installation, improper use or care or any Acts of God. Parts that fail or become defective during the warranty period shall be repaired or replaced, at our option, within 90 days of the receipt of defective product, barring unforeseen delays, without charge.

Proof of purchase is required for warranty service. In the event proof of purchase is not available, the manufacturing date of the product will be the sole determination of the purchase date.

To obtain warranty service, please contact the place of purchase or the nearest Hayward Authorized Service Center. For assistance on your nearest Hayward Authorized Service Center please visit us at www.haywardpool.ca.

Hayward shall not be responsible for cartage, removal, repair or installation labor or any other such costs incurred in obtaining warranty replacements or repair.

The Hayward Pool products warranty does not apply to components manufactured by others. For such products, the warranty established by the respective manufacturer will apply.

The express limited warranty above constitutes the entire warranty of Hayward Pool Products with respect to its pool products and is in lieu of all other warranties expressed or implied, including warranties of merchantability or fitness for a particular purpose. In no event shall Hayward Pool products be responsible for any consequential, special or incidental damages of any nature.

Some states do not allow a limitation on how long an implied warranty lasts, or the exclusion of incidental or consequential damages, so the above limitation may not apply to you. This warranty gives you specific legal rights, and you may also have other rights, which vary from state to state.

Hayward Pool Products Canada
2880 Plymouth Drive
Oakville, ON L6H 5R4

*Supersedes all previous publications.

FOR FURTHER INFORMATION OR CONSUMER
TECHNICAL SUPPORT, VISIT OUR WEBSITE AT
www.haywardpool.ca



Hayward is a registered trademark and HydroRite is a
trademark of Hayward Industries, Inc. © 2015 Hayward Industries, Inc.

All other trademarks not owned by Hayward are the property of their respective owners.
Hayward is not in any way affiliated with or endorsed by those third parties.

USE ONLY HAYWARD GENUINE REPLACEMENT PARTS