

Polaris Vac-Sweep® 380

Part# F3

Key No.	Part No.	Description	Pieces in Model	Pieces per Part No.
1	9-100-1021*	Zippered All-Purpose Bag	1	1
2	9-100-1152	Housing, Turbine Upper	1	1
3	9-100-1114*	Hub Cap	3	1
4	9-100-5107	E-Clip, Stainless Steel	10	1
5	9-100-1108	Ball Bearing	8	1
6	C10*	Tire, Max Trax®	3	1
7	9-100-1008*	Wheel, Double-Side	2	1
8	9-100-1017*	Belt Kit, Small and Large	1	1
9	9-100-7011	Shield, Bearing	3	1
10	9-100-1005	Frame (Warranty Only)	1	1
11	9-100-5125	Screw, 8-32 x 1/2" SS Pan Head	11	1
12	9-100-1139	Axle Block Kit (front and rear)	1	1
13	9-100-1010	Belt Divider, Transfer Pulley	1	1
14	B25	Orifice Tip w/ Tip Guard	1	1
15	9-100-1007*	Trans Pulley/Drive Shaft Assembly	1	1
16	9-100-5115	Screw, 8-32 x 3/4" SS	4	1
17	9-100-5130	Lock Washer, Axle Block	4	1
18	9-100-1132	Drive Train Gear Kit w/ Turbine Bearing	1	1
19	9-100-1103	Turbine Wheel w/ Bearing	1	1
20	9-100-1116*	Wheel, Single-Side	1	1
21	C131	Thrust Jet Kit	1	1
22	9-100-7008	Sweep Hose Barb Complete, White	1	1
23	B20	Adjustment Screw, Sweep Hose	1	1
24	B15*	Sweep Hose Attachment Clamp	1	1
25	9-100-9004	Base Weight	1	1
26	9-100-7170	Hose Clamp for WMS	6	6
27	9-100-7009	Jet Retainer	2	1
28	9-100-7010	Water Management System (WMS)	1	1
29	9-100-1155	Housing, Turbine Lower	1	1
30	9-100-3105	Sweep Hose Scrubber	1	1
30	R0522400	Sweep Hose Scrubber, 3/PK	1	3
31	9-100-5132*	O-Ring, Feed Pipe Assembly	1	1
32	9-100-7030	Top and Base Assembly	1	1
33	9-100-7003	Feed Pipe/Timer Blank Assembly	1	1
34	A20*	Float, Head	1	1
35	B5*	Sweep Hose Complete	1	1
36	B10	Wear Rings	8	1
37	9-100-1018	Bag Clip	1	1
38	9-100-1240	Top Housing	1	1
39	9-100-7026	Base Assembly	1	1
40	10-112-00	UWF® Restrictor Discs, Red and Blue	2	1
41	6-500-00	Universal Wall Fitting (UWF)	1	1
42	9-100-9001	UWF Connector Assembly	1	1
43	10-108-00	UWF Restrictor Kit	1	1
44	6-505-00	O-Ring, UWF/QD	1	1
45	9-100-9002	Pressure Relief Valve	1	1

Key No.	Part No.	Description	Pieces in Model	Pieces per Part No.
46	D29	Quick Disconnect, UWF	1	1
47	D15	Nut, Feed Hose	10	1
48	D44	Adapter Hose, 8-1/2"	1	1
49	48-080	In-Line Filter Assembly	1	1
50	48-222	Screen, In-Line Filter	1	1
51	D10	Float, Feed Hose	9	1
52	D45	Feed Hose, 10'	2	1
53	D20	Swivel, Ball Bearing	2	1
54	D50	Feed Hose, Leader, 10'	1	1
55	652	Backup Valve Kit	1	1
56	654	Case Kit for 652	1	1
57	657	Collar, Backup Valve	1	1
58	653	Mechanism for 652	1	1

*Suggested stocking part

380 Rebuild Kit

Part# 9-100-9030

No.	Part No.	Qty.
1	9-100-1014*	1
2	9-100-1152	1
3	9-100-1114*	3
4	9-100-5107*	10
5	9-100-1108*	8
6	C10*	3
7	9-100-1008*	2
8	9-100-1017*	1
9	9-100-7011	3
12	9-100-1139	2
15	9-100-1007*	1
18	9-100-1132	1
20	9-100-1116*	1
21	C131	1
22	9-100-7008	1
23	B20	1
24	B15*	1
25	9-100-9004	1
27	9-100-7009	2
28	9-100-7010	1
29	9-100-1155	1
32	9-100-7030	1
33	9-100-7003	1
34	A20*	1
35	B5*	1
55	652	1

380/360 Tune-Up Kit

Part# 9-100-9010

No.	Part No.	Qty.
1	9-100-1014*	1
2	9-100-1152	1
3	9-100-1114*	3
4	9-100-5107*	10
5	9-100-1108*	8
6	C10*	3
7	9-100-1008*	2
8	9-100-1017*	1
9	9-100-7011	3
12	9-100-1139	2
15	9-100-1007*	1
18	9-100-1132	1
20	9-100-1116*	1
26	9-100-7170	6
30	9-100-3105*	1
31	9-100-5132*	2

NOTE: Black Max™ parts are not indicated on exploded parts diagrams. See Black Max Parts List on pages 363-365.



PosiTrax® Tire (part# C13) available as an accessory for fiberglass and tile pools.

Polaris Vac-Sweep® 380

Part# F3

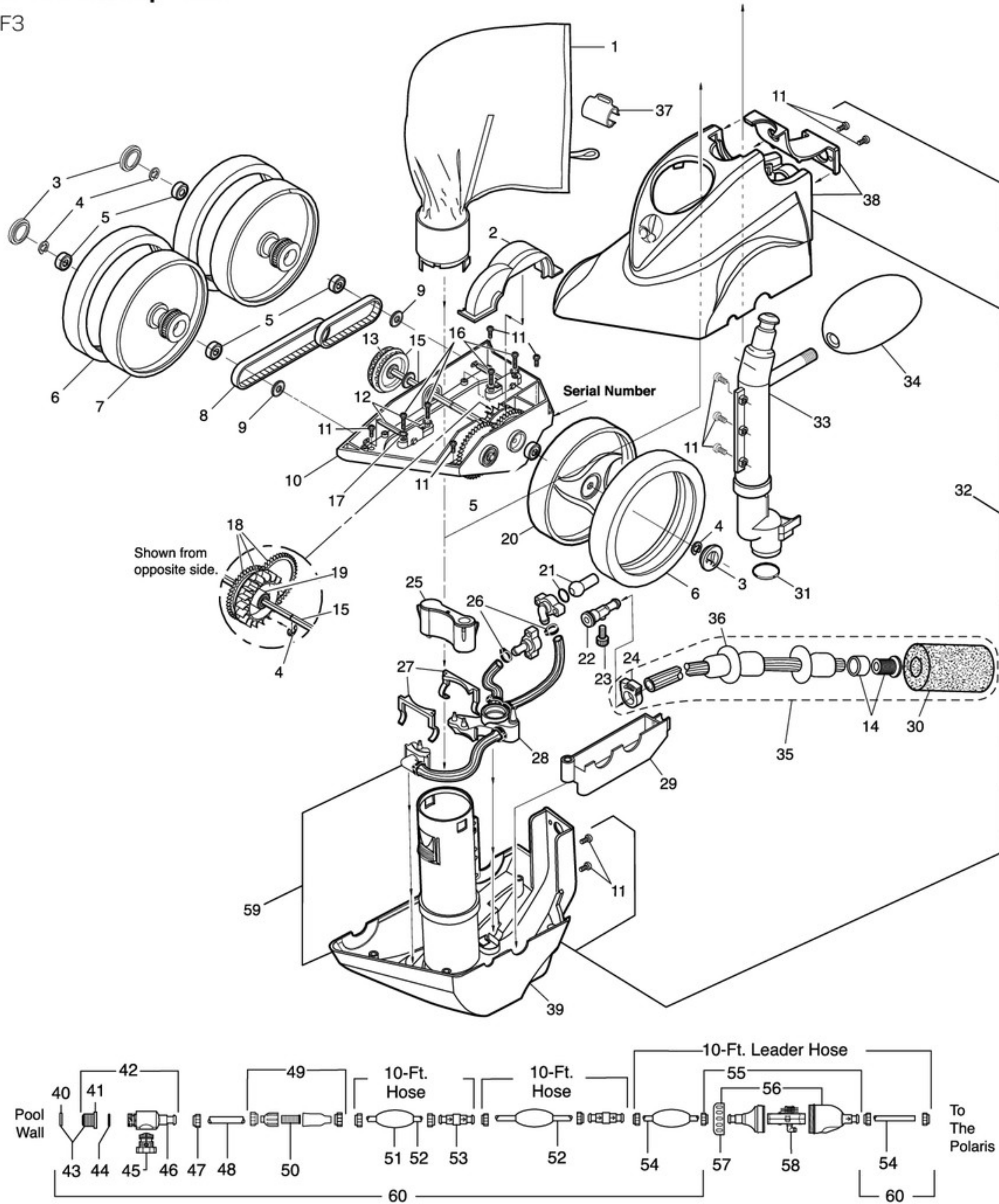

Key No.	Part No.	Description	Pieces	
			Pieces in Model	per Part No.
59	9-100-7045	Water Management Base Assembly Complete	1	1
60	65	Polaris Feed Hose Complete w/ UWF*, No Backup Valve, No In-line Filter	1	1

*Suggested stocking part