

PLACE
STAMP
HERE

Mail today to –

Aqua Vac Systems, Inc.
1711 Longwood Road
West Palm Beach, FL 33409
Attn: Warranty Records

Fold, stamp and mail or fax to 561-688-0217 or register on the web at www.aquavacsystems.com

Serial # _____ TigerShark

(Located inside filter area)

Registration of Warranty

This registration card must be mailed within 10 days of purchase to secure limited warranty.
FOR USE IN THE U.S.A. ONLY.

Name _____

Address _____

City _____ State _____ Zip _____

Date Purchased _____

Is this replacing another pool vacuum? Yes ___ No ___ If yes, what brand? _____

Purchased from _____

City _____ State _____ Zip _____

The size of my pool surface is _____ x _____ Surface is _____

Have you seen us on the internet? Yes ___ No ___



Limited Warranty

WARRANTY REGISTRATION CARD

Please fill out the warranty registration card on the cover of this manual. Give complete information as requested on the card, and return to Aqua Vac Systems. Any information or questions you may have concerning your Tigershark or this warranty may be obtained from Aqua Vac Systems. No dealer, distributor, or other similar person has any authority to make any warranties or representations concerning Aqua Vac Systems, Inc.'s products or to extend this warranty beyond the express items contained herein. Accordingly, Aqua Vac Systems, Inc. assumes no responsibility for any such warranties or representations beyond the express items contained in this limited warranty. This limited warranty is valid and enforceable only in the United States of America on Tigersharks that are owned and operated in the United States of America. This warranty gives you specific legal rights. You may also have other rights which vary from state to state. Your Tigershark Pool Cleaner has been manufactured, tested and inspected in accordance with carefully specified engineering requirements. It is warranted to be free from defects in material and workmanship.

<u>MODEL</u>	<u>WARRANTY PERIOD</u>	<u>COVERAGE</u>
TigerShark	1 - Year	Parts & labor on complete unit,
TigerShark 2	1 - Year	power train, motor unit,
TigerShark 2 Plus	1 - Year	and power supply, excluding
TigerShark Plus	3 - Years	filters.
TigerShark QC	3 - Years	

This limited warranty includes both parts and labor for the periods above noted and is available only to the original purchaser (USA only).

EXCEPTIONS AND EXCLUSIONS FROM WARRANTY

The Tigershark must be used with electrical requirements as indicated on the Tigershark Power Supply. Otherwise damage, defects, malfunctions or other failures of the Tigershark arising from use on electrical supply not as indicated are excepted and excluded from this warranty.

Defects, malfunctions, failure or damage of the Tigershark caused by improper, unreasonable, or negligent use or abuse by the consumer, are excluded from this warranty.

If any repair is made on your Tigershark by anyone other than authorized personnel (designated to perform such work) without first having obtained factory instructions, Aqua Vac Systems, Inc., at its sole option, may determine that this warranty will not apply and that reimbursement for such repair will not be made because of failure to comply with such factory specified instructions.

Filter cartridges are not covered by this warranty and will be replaced only with your prior approval of the charges.

Any unit that is used outside the continental U.S. is excluded from this warranty. AquaVac Systems shall be held harmless outside the continental U.S.

INSTRUCTIONS TO OBTAIN WARRANTY REPAIR

To obtain repair of your Tigershark under this warranty, the following procedure must be used:

- Select the nearest Aqua Vac Systems Factory Authorized Service Center from the enclosed list and contact them to make service arrangements.
- Ship the Tigershark, together with two extra photocopies of satisfactory evidence of the purchase date to the Factory Authorized Service Center with shipping and delivery charges prepaid.

If you are unable to locate a Factory Authorized Service Center, you may call Aqua Vac Systems, Inc. at 1-800-327-0141 for the nearest location or visit our website at www.aquavacsystems.com.

TERMS

If a warranty claim is made within the warranty period, your Tigershark will be repaired at no charge (parts & labor) and will be returned to you or the service center freight prepaid.

After the warranty period, repairs will be made only with your prior approval of the charges and the unit will be sent back to you freight collect.

When requesting warranty repair, PLEASE MAKE CERTAIN to state the serial number inside the main case of the cleaner.

REPLACEMENT

In the event of a defect, malfunction, or failure of your Tigershark, or any warranted part within the warranty period, Aqua Vac Systems, Inc. may at its sole option and own expense, replace the Tigershark or any warranted part, with another new or factory rebuilt identical or reasonably equivalent unit or part, in lieu of repairing the defect.



Owners Manual

All Models - TigerShark, Plus, 2,
2 Plus & QC



Contents

General Information.....	6
General Operating Instructions ...	6
TigerShark QC, Plus and 2 Plus Operating Instructions	8
Remote Control Trouble Shooting. .	9
Machine Assembly/Parts	10
Maintenance	11
Trouble Shooting	12
Specifications	13
Figures.....	14-17
Safety Precautions	18
Preventative Maintenance.....	19
Parts Ordering Instructions.....	19

The World's Best Pool Cleaners
For More Than 40 Years



1711 Longwood Road, West Palm Beach, Florida 33409
USA Toll Free 1-800-327-0141 • (561) 688-0211 • Fax (561) 688-0217

E Mail: info@aquavacsystems.com

www.aquavacsystems.com

To order parts call: 800-949-9892

GENERAL INFORMATION

Congratulations on your purchase of an TigerShark microprocessor controlled, fully automatic pool cleaner. The TigerShark represents the highest standard in design, performance, and quality. This manual contains important information regarding the operation and maintenance of your TigerShark. Please read it carefully before putting your TigerShark into use.

Deterioration, discoloration or brittleness of any pool finish can be caused over time separately by, or in combination with, age, incorrect pool water chemistry, improper installation, and other factors. Customer hereby disclaims any and all claims, and releases Manufacturer from any and all claims for damages to any pool plaster or vinyl liner in Customer's pool by reason of the use and/or operation of the Cleaner. Under no circumstances shall the Manufacturer be liable for any loss or damage, whether direct, consequential or incidental, arising out of the use or inability to use the cleaner in Customer's pool.

FEATURES

- The TigerShark independently scrubs, vacuums, and filters your pool.
- No installation, no attachments. Just drop it in and turn it on. It is completely automatic.
- Filter cleaning is much easier with the new patented cartridge type filter element.
- Adaptive Seek Control Logic (ASCL®) Microprocessor control optimizes cleaning routine for each individual pool size and shape.
- Electronic Self-Diagnostics and Overload Protection.
- Simple Direct Drive design w/non-corrosive bearings for high reliability.

GENERAL OPERATING INSTRUCTIONS

Take a moment to get familiar with the TigerShark using the figure on page 10. Throughout this manual reference to this figure is made when referring to different components of the TigerShark.

1. Select the nearest GFCI (Ground Fault Circuit Interrupter) protected 110-120 volt AC outlet (220-240 volt for 240 volt models).
2. Place the power supply (#1) so that the TigerShark can reach all the walls of the swimming pool and the power supply is at a minimum distance of 10 feet from the pool edge (page 10 Fig. a). The length of the standard TigerShark cable is 55 feet. (TigerShark2® cable is 100 feet).
3. Connect the floating cable (#2) to the power supply.
Use only the original TigerShark Power Supply manufactured by Aqua Vac Systems.
4. The TigerShark has an adjustable handle (#3). The handle must be locked in a **diagonal position** in order to ensure optimal cleaning results. The handle has two diagonal positions. Reverse handle position after each use. (page 10, Fig. b) to minimize cord twisting.

5. Place the TigerShark in the pool. It will slowly sink to the bottom of the pool as the air inside is released. Submersing by hand is helpful.

6. Connect the power supply to the GFCI protected outlet and switch to the “on” position. The TigerShark will perform a self-diagnostics routine for several minutes before starting the cleaning cycle.

The QC will go into Quik Clean cycle.

Caution: DO NOT switch power supply ON when the TigerShark is out of water. This may result in damage to the pump & drive motor seals, which will VOID the warranty.

7. The TigerShark will automatically shut off after a cleaning cycle of 3 hours. (90 minutes for Quick Clean, 7 hours for the TigerShark2®). If your pool is cleaned in less time than 3 hrs, you may shut the TigerShark off manually by switching the power supply to the off position.

Should a second cleaning cycle be required, switch OFF the power supply for 10 seconds and restart.

8. After the pool has been cleaned, switch OFF the power supply before removing the TigerShark from the pool.

9. Remove the TigerShark from the water at the shallow end of the pool by pulling the cable until the TigerShark reaches the surface. Then lift it out slowly using the handle, NOT the cable.

Caution: When pulling the cable, reel it in hand-over-hand - **DO NOT** reel it around your arm.

NEVER ENTER THE SWIMMING POOL WHEN THE AQUA VAC IS OPERATING.

Optimum operating water temperature range for the TigerShark is 50°F - 100°F. Water temperatures outside of this range do not drastically inhibit the operation of the pool cleaner.

Remove the TigerShark from the pool after each use. Keeping the TigerShark permanently in the pool may result in additional service requirements.

TIGERSHARK QC OPERATING INSTRUCTIONS

1. For installation, setup and general operation information refer to the General Operating Instructions located on page 6. For selection of the desired cleaning cycle follow steps 2 and 3 below.
2. When the TigerShark QC model is initially switched on, the Quik Clean cycle will automatically be selected, this is indicated by the light on the cycle selection switch located on the power supply. The TigerShark QC pool cleaner will automatically shut-off in approximately 90 minutes.
3. To select a Full Clean cycle, depress the FULL CLEAN button at anytime after the cleaner has been started, the Full Clean cycle will be indicated by a light on the cycle selection switch. In the Full Clean cycle the unit will automatically shut-off in approximately 3 hours.

Note: In the Quik Clean mode, the TigerShark will adequately clean pools with light debris loads. For heavier loads and increased wall surface cleaning, select the FULL CLEAN mode.



TIGERSHARK PLUS AND TIGERSHARK 2 PLUS OPERATING INSTRUCTIONS

1. For installation, setup, and general operation information refer to the General Operating Instructions located on page 6.
2. For the best operation of the remote control feature always place the Power Supply in an area in clear sight and within 75 feet of the Remote Control. The Remote Control can be operated at any time without disrupting the cleaning cycle.
3. To turn the cleaner while in operation depress and hold the button next to the desired turning function indicated in the front of the hand held remote control. When the button is released the turning function will stop and the TigerShark Plus will resume its programmed operation.



HAND HELD REMOTE CONTROL

TROUBLE SHOOTING THE REMOTE CONTROL FUNCTION

If the TigerShark Plus does not turn when the remote control is activated:

- Be sure to aim hand held toward power supply, not the unit.
- Be sure there are no obstructions between the remote control and the power supply.
- The distance between the remote control and power supply should not exceed 75 feet. Moving closer will ensure better reception.
- The batteries in the remote control may need to be replaced. (Requires one CR2032 lithium battery.)
- The overload protection breaker located on the front of the power supply may be tripped. To reset depress the small black button located above the flotation cord connection on the power supply.
- The Turning Foot may be lodged with debris. Turn cleaner off and remove from the pool. Manually work foot in and out to clear any debris, foot should slide easily.

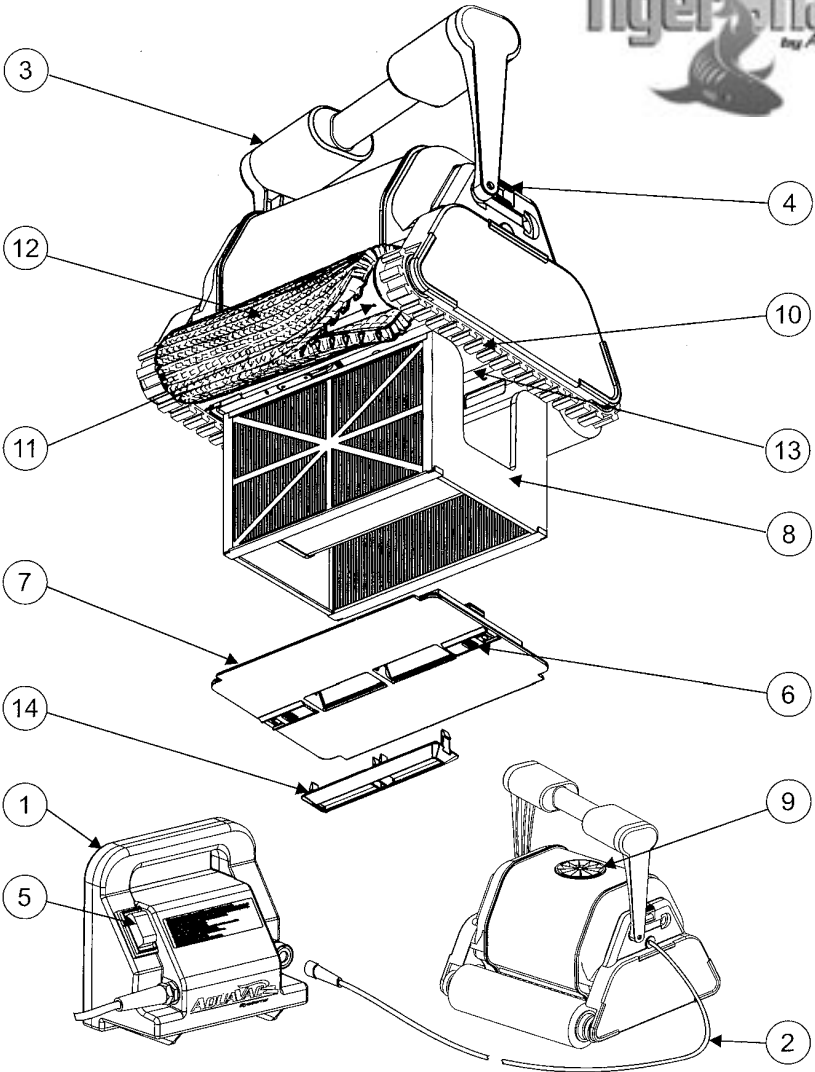

- | | |
|----------------------------|------------------------------------|
| 1. Power Supply | 8. Filter Cartridge |
| 2. Floating Cable 55'/100' | 9. Impeller Tube |
| 3. Handle | 10. Drive Track |
| 4. Handle Latch | 11. Wheel |
| 5. On/Off Switch | 12. Wheel Brush |
| 6. Bottom Lid Latch | 13. Sealed Motor Unit |
| 7. Bottom Lid Assembly | 14. High Velocity Inlet (Optional) |

MAINTENANCE

Clean the filter cartridge after each use:

- Place the TigerShark on its side. Release the bottom lid latches (6) (Fig. d) and remove the bottom lid assembly (7) (Fig. e).
- Pull out the filter cartridge. Your filter is a three piece filter, Part #70100 - you may or may not remove the elements for thorough cleaning. Using a garden hose with a spray nozzle, pressure wash the filter elements to remove debris. Hold the filter elements as shown to allow the debris to fall out (Fig. f).
- Wash the inside of the bottom lid.
- Replace the filter cartridge in TigerShark (Fig. g).
- Install bottom lid and slide latches in lock position.
- Filter cleaning solution can be used to remove D.E., excessive dirt and/or sand.

Remember: The cleaner your filter is, the more efficient your cleaner will perform.

Periodic Cleaning of Moving Parts

WARNING: Disconnect the power supply from electrical outlet before cleaning moving parts.

- Inspect the pump outlet to ensure that no debris or hair has clogged the impeller. The impeller can be cleaned by removing the impeller tube (9) by twisting (rotating) it (Fig. h).
- Remove any debris that has accumulated between the tracks (10) and wheels (11).

Storage

When out of the water, store TigerShark on its side in a dry, shady location at temperatures between 40°F - 115°F (Fig. i).

Cable Care

With continued use, the cable may become coiled (like a telephone cord). To correct this, lock the handle in the opposite diagonal position (Fig. b). The TigerShark will then circle the pool in the opposite direction and uncoil the cable. Also, periodically stretching the cord out in the sun should remove any cord twists.

Reverse handle position after each use to avoid cable coiling.

IMPORTANT: The cable should be checked periodically for any external damage.

IMPORTANT TIPS

- Cleaning the filter cartridge after every use maximizes the unit's performance.
- If the TigerShark has trouble climbing the pool walls during the middle of the cleaning cycle, clean the filter and resume cleaning.
Replace worn brushes (#12) to ensure maximum cleaning performance.
- If granular chemicals are used in the pool on a daily basis, an automatic or floating dispenser is recommended, as it retains the calcium sediment sometimes contained in granular chlorine.
- It is recommended not to operate the TigerShark until all chemical powder is dissolved because it can clog the filter.
- In a pool with usually high calcium content, more frequent cleaning of the filter is recommended.
- Save the TigerShark original carton for extended storage or shipping requirements should your TigerShark require dealer service (page 13, Fig. j).
- The sealed Motor Unit (#13) and the Power Supply (#1) contain no user-serviceable parts. Opening them will automatically VOID your warranty.
- Remove items such as thermometer, toys and the like from the pool before using the unit. Such items can jam the unit and cause damage to the unit and/or your pool.

TROUBLE SHOOTING

If TigerShark cannot climb pool walls:

- Clean the filter. It may be clogged or too heavy from excessive debris.
- Brushes may be worn. Inspect brushes and replace if worn.

If TigerShark fails to pick up fine or heavy debris:

- Clean the filter. It may be clogged.
- An optional high velocity inlet is available from your dealer which clips on to the bottom lid (page 10, Fig. c). This inlet creates extra suction for lifting fine or heavy debris. This part also can be helpful if unit becomes routinely stuck on a raised main drain.

If TigerShark starts working momentarily but then stops working:

- Impeller may be clogged or jammed with debris. Check and clean if necessary following the instructions in the maintenance section on page 7.
- Brush rollers or drive tracks are stuck. Check for debris and clean if necessary.
- TigerShark is out of the water. Put TigerShark in water and reset the power.

You may go to "TigerShark Owners - FAQs" at our website for additional information.

SPECIFICATIONS

Suction Rate	75 gal/min
Current Consumption	0.78 amps
Weight (w/o cable)	21.5 lbs
Cable Length, Type	55 ft (100 ft for TigerShark 2®) Floating
Materials	High Impact ABS - Metal Parts of Non-Ferrous Stainless Steel

Motor Unit

	PUMP	DRIVE	PCB
Speed (rpm)	2,700	55	-
Voltage	24V DC	22V DC	5V DC
Current (amp)	2.62	0.63	-
Waterproof Sealing	Double Redundant Radial Shaft Seals & O-Rings.		
Housing	Sealed, Watertight, High Impact Polypropelene		
Overload Protection	Electronic Overload Monitoring w/auto-shutoff.		
Self-Diagnostics	Electronic Power-On Self-Test w/Memory - For Authorized Service Center Use.		

Filter

Type	Removable, Re-Usable, Pleated Element Cartridge
Media	Pleated Cellulose/Polyester Blend
Porosity	5 micron
Area	1,000 sq. inches

Cleaning Routine Control

Type	Adaptive Seek Control Logic (ASCL®) Microprocessor
Cleaning Cycle	3 hrs (7 hrs for TigerShark2®)

Drive System

Direct Drive w/Polyurethane Drive Track & Acetal/Stainless Steel Bearing System

Power Supply

Primary Voltage	110-120 volt AC (220-240 volts for 240 volt model)
Secondary Voltage	24V DC
Rated Output Current	4 amps
Weight	8.3 lbs

These specifications may vary in different swimming pools and electrical supply outlets.

Shipping

	Tigershark/TigerShark 2	
Carton Dimensions	Height	19 in. (48.3 cm) 21 in. (53.3 cm)
	Width	19 in. (48.3 cm) 19 in. (48.3 cm)
	Length	19 in. (48.3 cm) 21 in. (53.3 cm)
Shipping Weight	42 lbs (19.1 kg)	

Although the TigerShark has been tested to work in a wide range of swimming pools, AquaVac Systems cannot guarantee proper operation in all swimming pools.

Figures

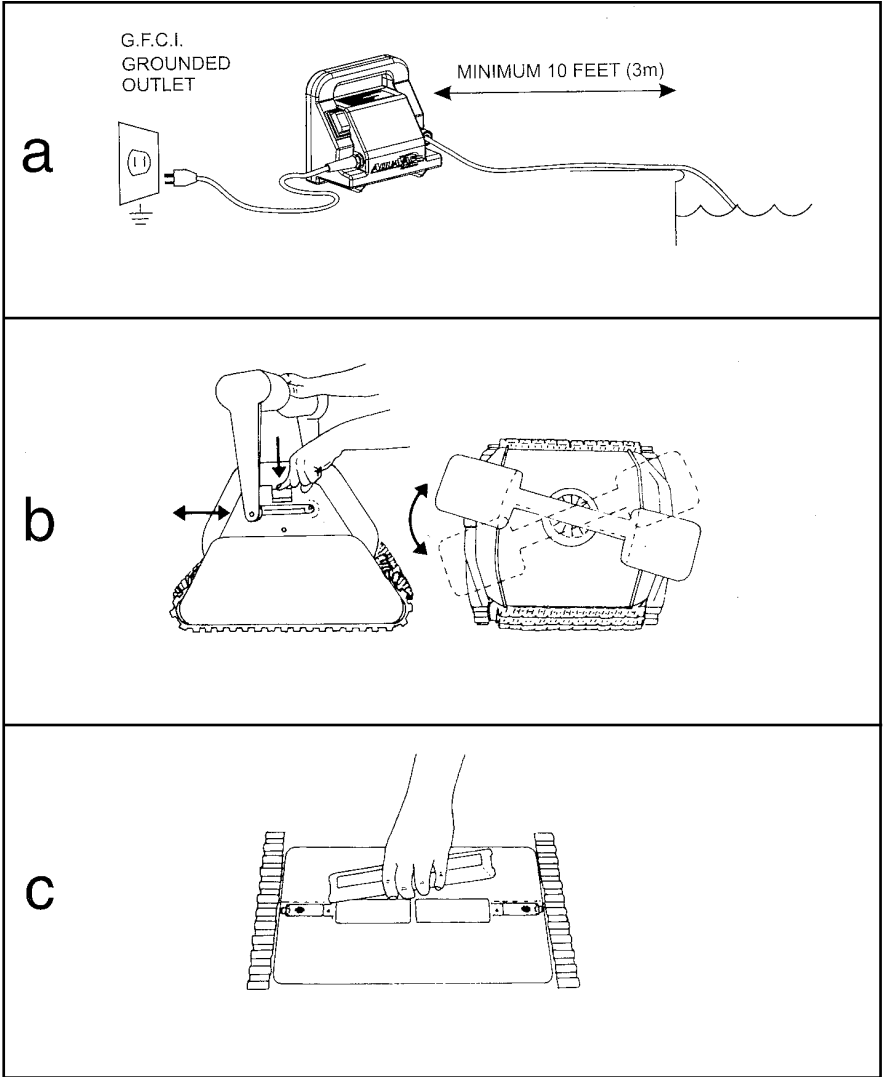

Figures cont.

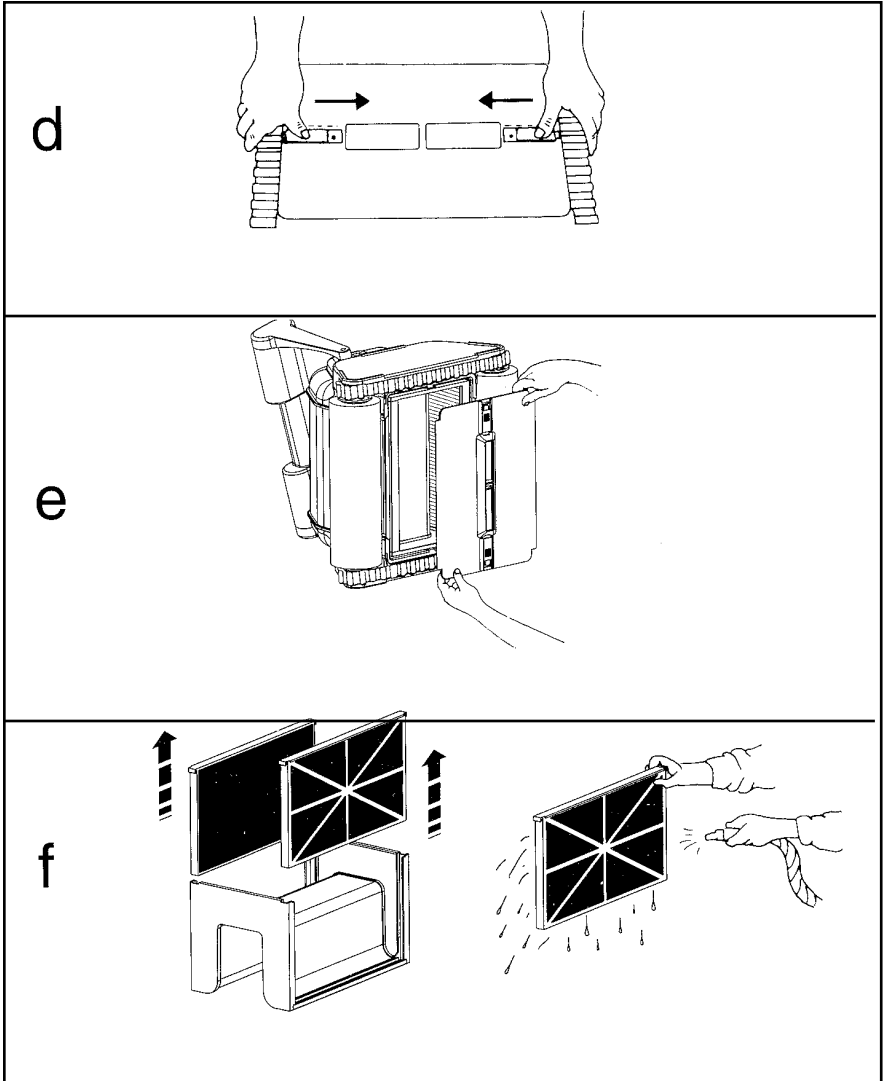

Figures cont.

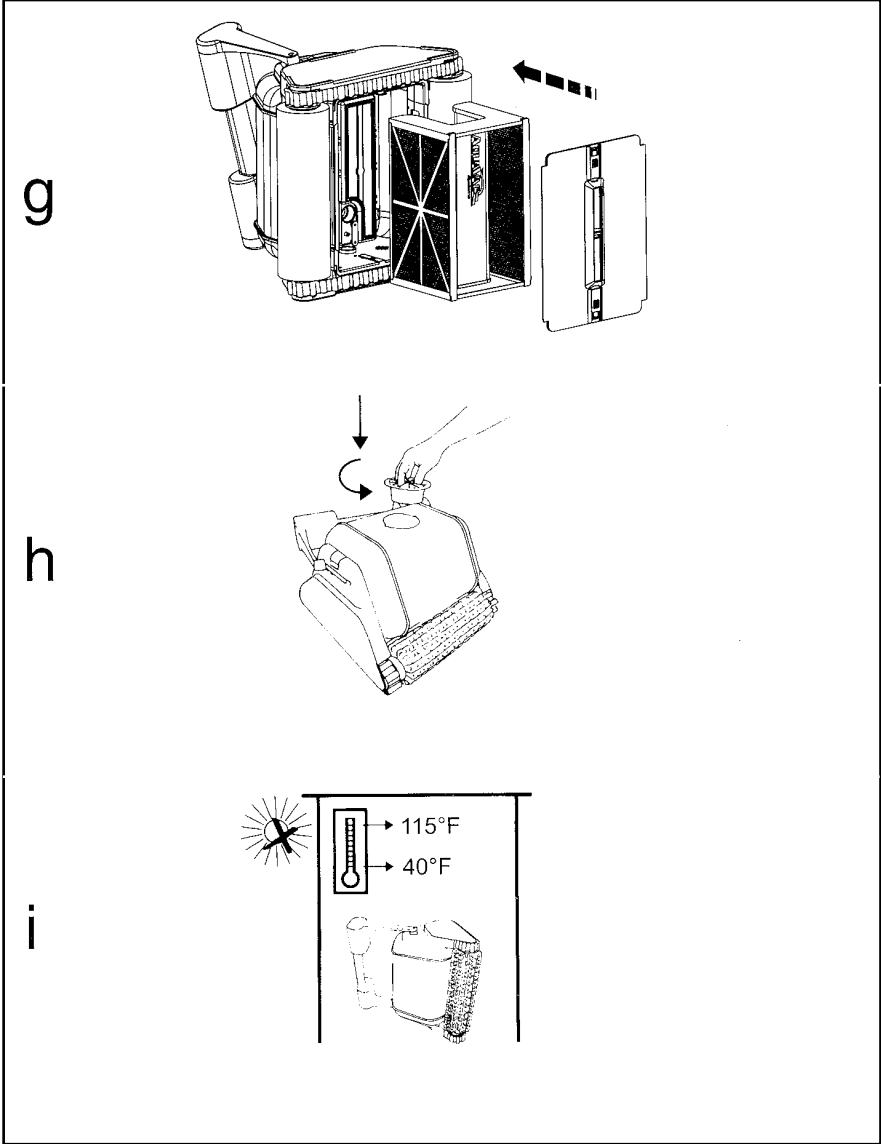

Figures cont.

j

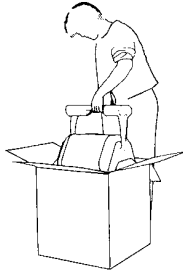

NOTES

SAFETY PRECAUTIONS

The TigerShark automatic swimming pool vacuum cleaner has been manufactured to the standards of CSA (Canadian Standards Association) and ETL (Edison Testing Laboratories) with the highest degree of care and concern for safety. We suggest the following safety precautions become part of your pool safety regulations:

1. ALWAYS PUT THE MACHINE INTO THE WATER BEFORE CONNECTING IT TO THE ELECTRICAL OUTLET.
2. IT IS IMPORTANT FOR SWIMMERS' SAFETY TO REMOVE THE UNIT IMMEDIATELY FOLLOWING USE. THIS CAN ALSO IMPROVE THE OPERATING LIFE OF YOUR TIGERSHARK .
3. BE CERTAIN THE MACHINE IS ONLY PLUGGED INTO A GROUNDED ELECTRICAL OUTLET EQUIPPED WITH AN APPROVED AND PROPERLY OPERATING GROUND FAULT CIRCUIT INTERRUPTER (GFCI).
4. DO NOT HANDLE MACHINE WHILE IT IS PLUGGED INTO THE ELECTRICAL OUTLET.
5. DO NOT USE AN EXTENSION CORD. THIS COULD CREATE A SAFETY HAZARD AND/OR DAMAGE YOUR UNIT.
- 6. ALWAYS STAY OUT OF THE POOL WHILE CLEANER IS IN OPERATION.**
7. NEVER ALLOW PLUG TO ENTER THE POOL.
8. DO NOT OPERATE THE MACHINE OUT OF WATER. THIS WILL DAMAGE THE MOTOR SEAL AND VOID THE WARRANTY.
9. DO NOT DRAG THE MACHINE OUT OF THE POOL AGAINST THE SIDE WALL. THIS COULD DAMAGE UNIT AND/OR YOUR POOL WALL.
10. SOME POOLS HAVE A CORNER OR A CORNER STEP CONFIGURATION THAT MAY CAUSE THE UNIT TO "HANG-UP;" THEREFORE, DO NOT LEAVE THE UNIT COMPLETELY UNATTENDED FOR MORE THAN 1/2 HOUR. OCCASIONAL OBSERVATION AND ATTENDANCE CAN ALSO REDUCE ANY TENDENCY FOR THE CORD TO TWIST.

While the TigerShark has been made to operate as safely as possible, we suggest you exercise reasonable care in the handling of the vacuum and inspect the electrical cord frequently for damage or wear, as with any other electrical appliance. After use, remove the unit and rinse with fresh water and remove any twists that may be present in the cord.

PREVENTATIVE MAINTENANCE

In order to maximize efficiency and receive long term service of your unit, we suggest the following:

- Thoroughly rinse entire unit after use.
- Clean filters thoroughly after each use—a clogged filter can decrease efficiency dramatically.
- Remove any twists in the cord after each use. Twisting should be minimal if the unit is functioning properly. Laying cord, straightened out in sunlight is helpful.
- Avoid allowing the unit to “cool down” in the water.
- Inspect belts and filter frequently. Replace when necessary.

Protect Your Investment!

Following these quick and easy steps will extend the life and efficiency of your TigerShark. If you have any questions, contact your local Service Center or call us at 1-800-327-0141, Monday - Friday, 8:30 a.m. - 5:30 p.m. EST.

PARTS ORDERING INSTRUCTIONS

Should you desire to order repair parts, follow this simple procedure:

1. Determine each of the parts you will need and identify them by part number. Use this book as a guide, be sure to note due to continual product improvement, parts may vary depending on the year of manufacture.
2. Contact your local Factory Authorized Service Center with the list of parts you will need. Be sure to advise the Service Center of the TigerShark serial number and the date of purchase. If you need the location of your nearest Service Center, please call Aqua Vac Systems, 1-800-327-0141 or 561-688-0211. Or visit our website at www.aquavacsystems.com.
3. All parts under unconditional warranty are confined to the specific limitations as stated.



**ALL OTHER
POOL CLEANERS
BEWARE!**

Pool Cleaning Doesn't Get Any Easier Than This.

- **Easy Clean Filter Cartridges**
- **Worry Free Maintenance**
- **No Hoses, Hook-ups or Attachments**
- **Nationally Honored Warranty Program**



**Chosen to clean the pools at
the past eight Olympic games.**

AQUAVAC
Automatic Pool Cleaners

1711 Longwood Road, West Palm Beach, Florida 33409

USA Toll Free 1-800-327-0141

(561) 688-0211 • Fax (561) 688-0217

E Mail: info@aquavacsystems.com

www.aquavacsystems.com

To order parts call: 800-949-9892

rev 12/04