

LATHAM INTERNATIONAL

INSTALLATION INSTRUCTIONS FOR ACRYLIC / FIBREGLASS IN-WALL STEPS

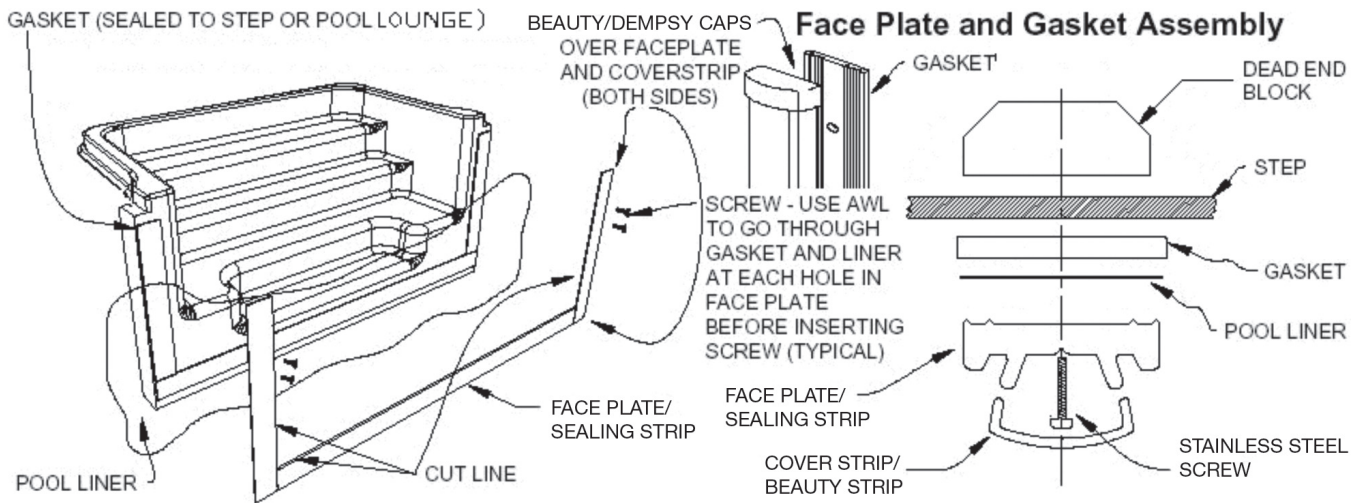

FIGURE 1.

PARTS LIST

EACH MODEL COMES WITH:

- | | |
|-----------------------------------|------------------------------|
| 1 - Step | 1 - Instructions booklet |
| 3 - Sealing strips | 2 - Beauty Caps (Dempsy Cap) |
| 3 - Beauty strips | 1 - Warranty |
| 1 - Set of stainless steel screws | 1 - Robertson bit |

INSTALLATION PROCEDURE

All Acrylic /Fibreglass In-Wall Steps feature thermoformed acrylic skins reinforced with fiberglass for toughness, lasting appearance, weather and UV resistant, for ease of maintenance. Each unit includes factory installed safety labels, production labels, gaskets with removable faceplates and cover strips. Attached packaging includes quadrex stainless steel screws with Robertson bit (square head bit), 2 beauty caps, installation instructions with support placement illustration and owners warranty card. At least two people should carry the unit to the intended location. Do not drop or abuse it.

1. With the step lying on its back remove the cover strips, faceplates and screw package and place them in a safe and accessible location. Faceplates are labeled as to position.
2. Put cardboard or similar padding on the ground and lay the top surface of the step on it. (Figure 2)

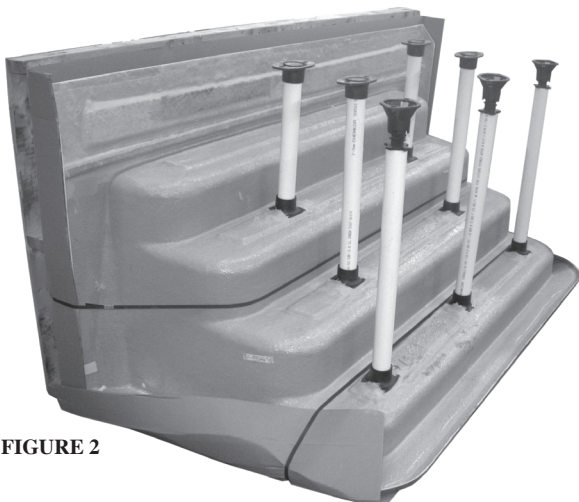

FIGURE 2

3. As shown in Figure 2 insert the support poles completely into the designated receptors on the tread supports. Step support pads should be attached to the bottom (ground end) of the poles except those supporting the top step; adjustable foot pads should be attached to the bottom (Ground end) of the poles supporting the top step.(2' in-Wall Ladders do not require bracing)
4. It may be necessary to secure the adjustable foot pad to the pole using duct tape or insert the adjustable foot pad after the step has been positioned.

5. Lift the assembled unit and rotate it onto the leveling legs while moving it into position between intended adjacent pool wall panels. (Figure 2a) and (Figure 3)



FIGURE 2a

6. Plumb the face of the unit while positioning its face flush with the face (do not align with the gasket) of the adjacent pool wall panels. In addition, the top of the unit must be flush with the top of the panel Fig. 4 (Cantilever) and consideration given to coping application (Fig. 3). Level step, by using adjustable foot pads.

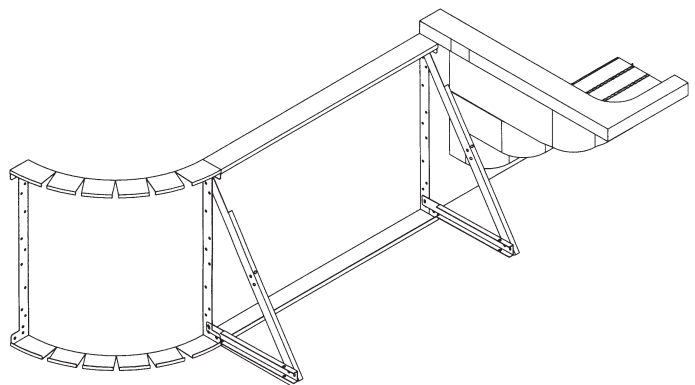

FIGURE 3. - Wall/Step Assembly - Standard Coping Application
Step is elevated to match coping height.

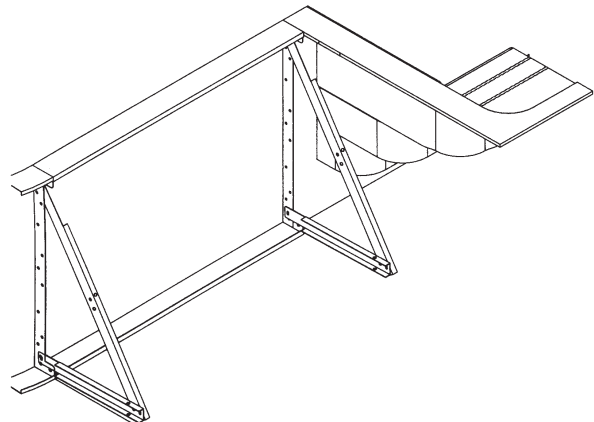

FIGURE 4. - Wall/Step Assembly - Cantilever Application
Step is installed flush with top of pool panel

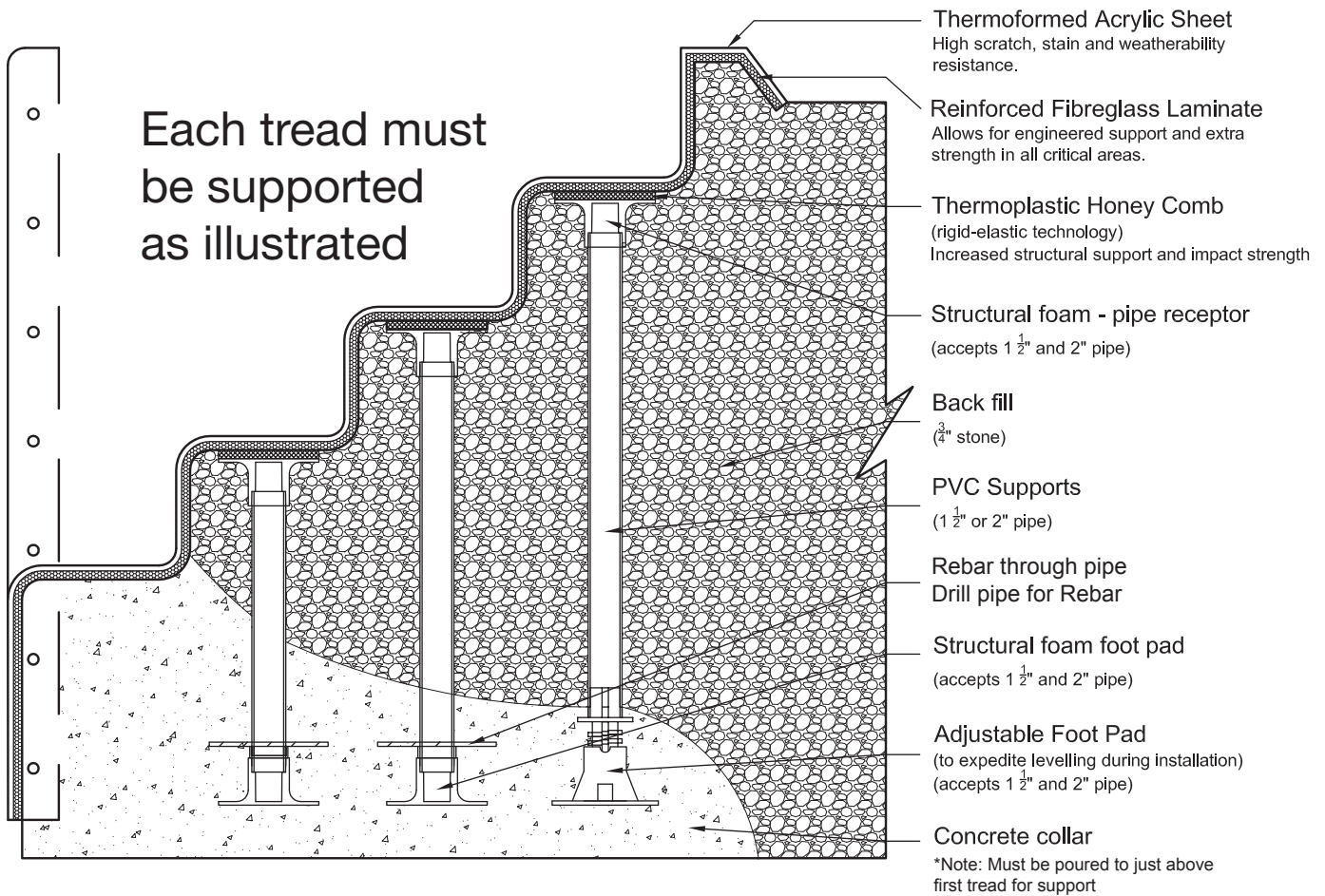

FIGURE 5. - Illustrating cross section of Figures 2 and 2a.

7. With the unit supported, plumb and flush with the panels, clamp its flanges to the flanges of the panels. Avoid covering the panel bolt holes with the clamps. C- Clamps or other deep-throated clamps are best suited for this procedure. Use the panels' bolt hole as templates and drill matching holes into step side flanges. If alternate hole alignment use outer holes as template.
8. Insert bolts into several hole openings, the bolt heads, with an oversize washer under them, must be on the step side of the flange assembly; snug bolts, allowing placement of the panel brace. Release the clamps and install panel braces adjacent to panel flange.
9. Insert balance of bolts with washers into each hole on each side of step. Place washers on bolt ends and thread nuts onto them. Be sure the panel and unit faces are plumb, and then tighten the nuts and bolts.
10. Across the front base of the step unit place a 2 x 4 or similar blocking and stake it in place. This blocking supports the step unit while the concrete collar is being poured. The concrete collar must be poured just above the bottom step for support and to avoid moisture in the backfill from freezing/expanding between the footing and bottom step. Fig. 5
11. Backfill the step unit, the same as the pool wall, taking extra care to eliminate voids under the steps by compacting. Backfill to just above the top flange as shown in Figure 5.
Recommended material
Pea Gravel
3/4" round washed stone
Washed sand
12. Install the coping to the pool walls so that it mounts flush to the top of the step unit on both sides. Or if cantilever style install liner receptor track.
13. If not already removed, remove the beauty/cover strips and then remove the sealing strips, using a medium Phillips (or #2 Robertson) screwdriver. The 2 vertical strips are marked TL (top left) and TR (top right), and the ends of the horizontal strips are marked L and R. Install the liner in the normal way and allow it to drape across the step opening.

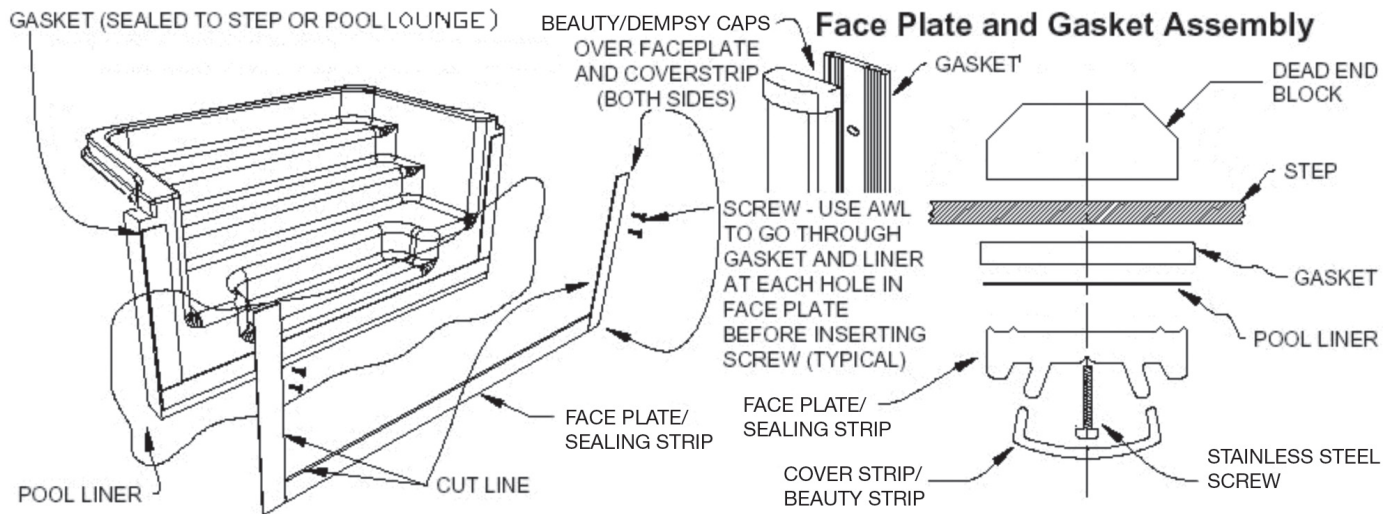
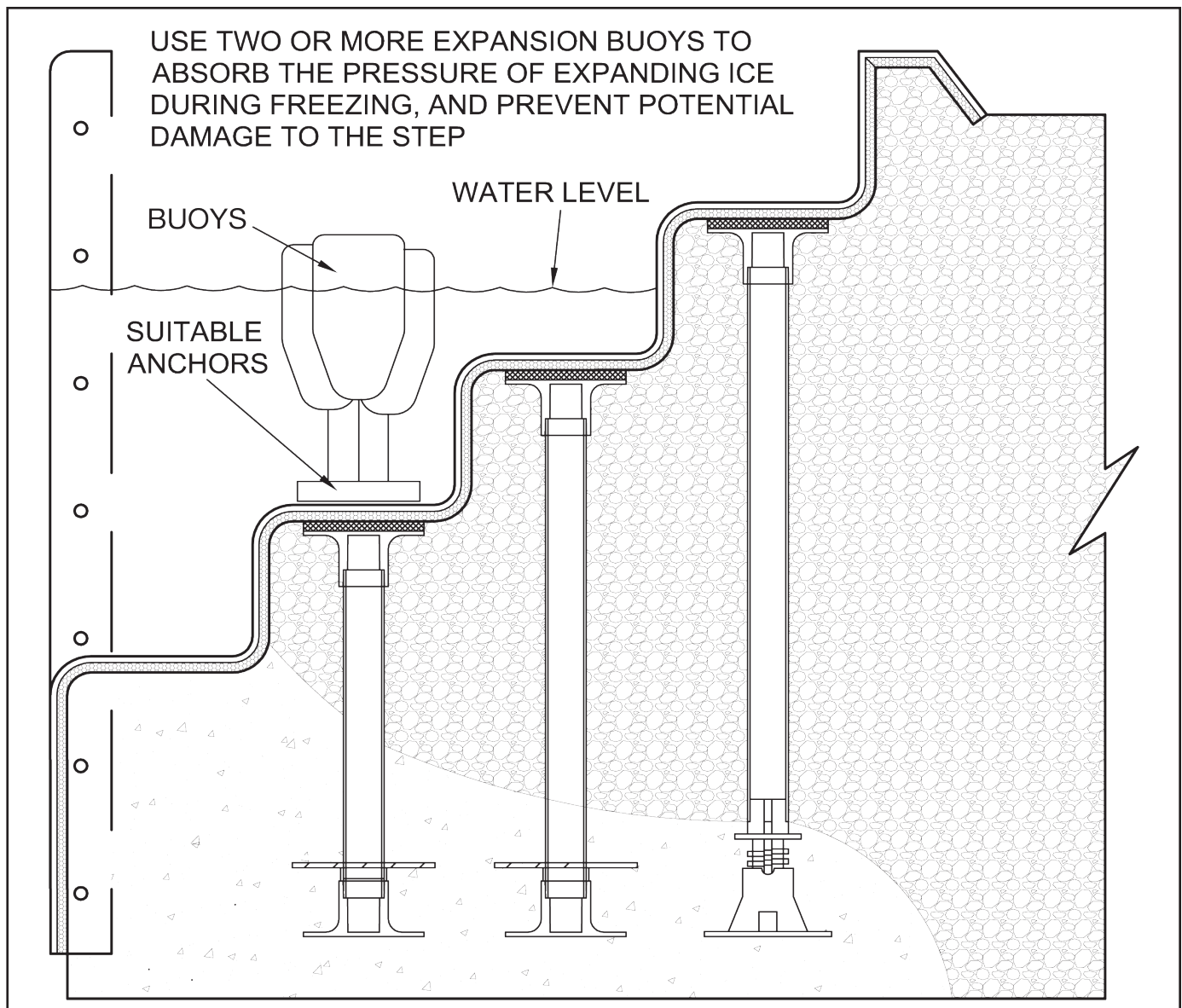

FIGURE 1.

14. (Optional) A step cover with liner track across the face maybe used to cover the step area, allowing the bead to be inserted into liner track holding the liner horizontal so that faceplates may be installed easily once liner is vacuumed into place. If step cover is unavailable a custom cut 3/4" Plywood maybe used in the face of the step area or on top of the step.
15. Install the vertical strips first, taking note of the L and R markings, beauty caps should be installed at this time. Trim caps for inside corner steps should be installed at this time. When installing horizontal strip ensure that there is enough liner between the pool floor and the strip so that the liner will lay against the pool floor, cove and bottom step riser, without wrinkling or over stretching. Push the liner into the step opening before installing any screws so that the liner lies flat, without wrinkling, against the adjacent pool walls. Tighten each screw until the screw heads bottom uniformly on the strip and give each screw a full turn. (Fig. 1)
16. Once the liner installation is complete use a sharp utility knife to cut away the excess vinyl on the inside edge of the face plate/sealing strip as shown in figure 1 "cut line".
17. Slide the top of the vertical cover strip under the beauty cap and snap the remainder into the faceplate. Snap the horizontal cover strip in the same manner.



WINTERIZING

Latham International In-Wall Steps installed in northern climates may be susceptible to the rigours of winter if not properly winterized. The following **MUST** be done in such climates.

1. Lower the pool level no lower than recommended in the pool guide for the pool construction used.
2. Install an expansion preventer in the step opening that will contract and expand with any ice movement and reduce stresses on the step unit. Such preventers can be as simple as 3 or 4 large plastic bottles or water tubes. These must be partially filled with anti-freeze/water mix, tied off, and set in place per Fig. 6 so that they float mostly submerged.

DECK TREATMENTS

Most deck treatments can be used with the Latham International in-wall steps. Regardless of the one chosen, care must be taken to ensure that **NO** concrete or mortar for the deck is allowed to get under the rear or side of the step unit. This can be accomplished by compacting the backfill just above the edge, thus avoiding step heaving in areas of heavy frost. A series of at least 3 deck joints running back from the step unit is recommended.

INSTALLATION TIPS

1. When pouring the concrete collar during installation the concrete should come just above the bottom step for support and to avoid any moisture in the back fill from freezing /expanding between the footing and bottom step.
2. The steps must be supported by back filling, this is best achieved using 3/4 stone.

CARE AND MAINTENANCE OF ACRYLIC POOL STEPS

Your walk-in-step unit is manufactured from a thermoformed acrylic sheet, reinforced with fibreglass material.

The Acrylic sheet is specially formulated for long-term resistance against UV rays, bacteria and extreme weather. Your step unit will require only a small degree of care and maintenance which should include the following:

1. ALWAYS maintain pool water in proper chemical balance.
2. When doing normal pool vacuuming and brushing, be sure to include the step unit, especially the tread areas.
3. For cleaning on any scum line that forms on your step unit, use the same cleaner that you use to clean the vinyl liner. If the scum line is heavy or if you find that there is a build up of a film, dirt or residue anywhere on the step unit, use a sponge or terry cloth with a household liquid detergent to clean and remove any stains from those areas. To prevent a scum line from building up, brush the water line area, weekly.
4. ALWAYS be sure that the step handrails are secured firmly in place and tight.

**CAUTION
STEPS MAY BE SLIPPERY
WHEN ALGAE OR BODY OILS
ACCUMULATE.**

5 Year Full Acrylic Fibreglass In-Wall Step Warranty

DATE OF PURCHASE _____

Latham International warrants to the original purchaser that if a Latham International inground acrylic fibreglass pool step product shall fail structurally due to a manufacturing defect within 5 years from the date of installation and the inground step has been installed in accordance with Latham International instructions using the specified support system, Latham International at its option will repair any such defect, or supply a new step, F.O.B. our plant. All Step treads must be supported, if all steps treads are not supported the warranty will be void. Latham International warrants the Acrylic surface to not split, crack or tear for a period of one (1) year. Latham International is not responsible for any additional materials and or labour/ installation costs associated with the replacement step.

This warranty is subject to the following additional terms and conditions.

Latham International Inground acrylic fibreglass pool steps are intended for use in residential swimming pools only. If this product should become unusable and/or ineffective because of a problem covered by this warranty, the purchaser must make any claims for warranty coverage as instructed on the reverse side of this warranty. Upon review of such claim, Latham International may instruct the purchaser to return the steps or the defective portion of the steps or to send digital photographs of the defective steps to Latham International. The purchaser will pay all appropriate shipping charges for the return of the product or portions thereof in accordance with its instructions. Upon inspections of the return//photographs, the purchaser will be informed as soon as possible as to the disposition of the claim.

This warranty relates only to manufacturing defect and does not cover fading or discolouration, staining, damage or failure

resulting from other causes, including, but not limited to, use of the product other than as steps in a residential swimming pool, negligence, misuse or abuse, chemical damage, damage results from improper use of Salt Chlorine Generator, exposure to excessive heat or cold, water loss, improper installation including, but not limited to, failure to use the specified support system, as shown on attached installation instructions. Warrantor shall not be responsible for freight, removal, or other such costs incurred in obtaining warranty replacement or repairs.

Under no circumstances shall Latham International be liable for special, incidental or consequential damages, including, but not limited to, any damages for loss of use of pool, injury to, or death of, any person or damage to property, and any claims therefore are hereby specifically disclaimed and excluded. Some States/Provinces do not allow the exclusion or limitation of incidental or consequential damages. Therefore the above limitation or exclusion may not apply. This warranty gives you specific legal rights, and may also have other rights which vary from State to State and jurisdiction to jurisdiction.

No representative of Latham International or any of its agents, distributors, or dealers has any authority to alter in any manner the terms of this warranty. Latham International is not responsible for any undertaking, representation or warranty by any other person beyond those expressly set forth in this warranty certificate.

The term of this warranty shall not create or extend any statute of limitations or other time limitation of any kind.

**Register your warranty at www.yourpoolwarranty.com
Call 1-888-MYPOOL2**

5 Year Full Acrylic Fibreglass In-Wall Step Warranty

LATHAM INTERNATIONAL • WARRANTY REGISTRATION

Complete and mail this information section to LATHAM INTERNATIONAL within 30 days of purchase. (Please Print)

PURCHASER _____ DATE _____ COLOUR _____ MODEL _____ SIZE _____

ADDRESS _____ PHONE _____

PROVINCE/STATE _____ POSTAL CODE _____ EMAIL _____

/ZIP CODE _____ ADDRESS _____

PURCHASED FROM _____

SERIAL NUMBER _____

Do you own a safety Cover? Yes No

Installed by Dealer Private Installer Consumer-Purchaser

“Important! Please read and sign”

“I have received and reviewed the Installation manual and contents”

PURCHASER’S SIGNATURE _____



Canadian and International Residents mail to:
430 Finley Avenue, Ajax, ONTARIO, CANADA L1S 2E3
Fax: (905) 683-3735 Tel: (905) 428-6990 Email: custserv@triac.com

US Residents mail to:
Latham International
787 Watervliet-Shaker Rd., Latham, NY 12110
800-833-3800

INGROUND STEP Warranty

HOW TO FILE A CLAIM

All necessary warranty and care information is enclosed with each Latham International Inground Step. It is the retailer's responsibility to present this information to the purchaser.

Latham International encourages you to complete and return the product registration card enclosed with your Inground Step, to Latham International. Our web site, www.yourpoolwarranty.com may also be used to register. While failing to register your purchase will not affect your warranty rights in any way, registration of your product ownership may simplify claims processing in the unlikely event you may need that type of assistance. Please follow these easy steps when contacting us:

- 1) If you believe you have a warranty claim, please contact the seller of the Latham International Inground step. The seller of their designee should assess the product and report their findings to Warranty Service at Latham International. If you have not received a response to your claim within 3 weeks from the date you first contacted your seller, please call our Warranty department toll-free at 888-MYPOOL2 (888-697-6652).
- 2) A warranty service representative will ask for a claimant's name, address, phone number, the date the step was installed, the business name of product seller and a description of the claimed defect. A claim number will be assigned. Please record and save the claim number. The Warranty Service representative may require the original seller/installer to inspect the product to verify the cause of the failure. The representative may require the return of the steps or the defective portion of the step and or digital or paper photographs of the area suspected of being defective, be sent to Latham International. The appropriate mailing address for the return or the photographs will be provided.
- 3) Upon review, the purchaser will be informed as soon as possible as to the disposition of the claim.

Latham International reserves the right to change its warranty claim filing instructions and procedures from time to time. Please contact your authorized Latham International Inground Step retailer for the latest instructions that apply to your warranty claim.
