

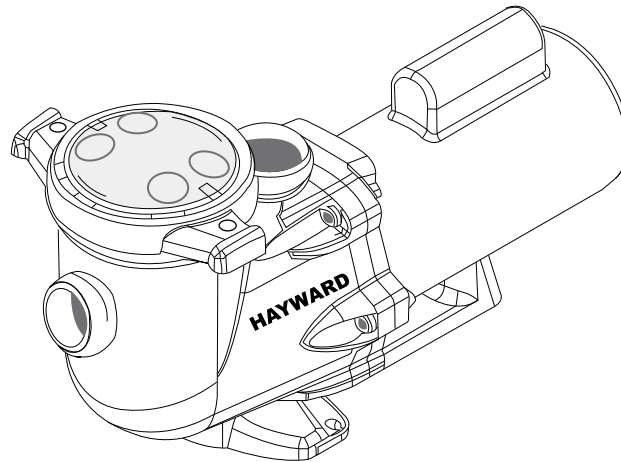

OWNER'S MANUAL
 INSTALLATION, OPERATION, & PARTS



TriStar™ Pump Series

The Hayward TriStar Pump is Specifically Engineered for the demanding requirements of today's in-ground swimming pool/spa that is equipped with large capacity filters, heaters, and pool cleaning equipment. The TriStar is a self-priming pump that incorporates an improved seal and impeller design that will provide many years of efficient, dependable, corrosion-free service. The advanced design provides superior performance while reducing maintenance requirements. **NOTE** - To prevent potential injury and to avoid unnecessary service calls, read this manual carefully and completely.

IMPORTANT - READ CAREFULLY

NOTE - The TriStar is a high performance, high efficiency pump. When replacing most existing pumps, **you can use a TriStar pump with a lower horsepower rating than the existing pump. Required: 2" Plumbing minimum.**

SAVE THIS INSTRUCTION MANUAL

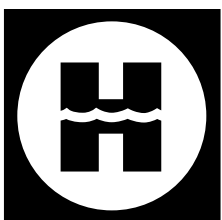

HAYWARD POOL PRODUCTS CANADA INC.
 2880 Plymouth Drive, Oakville, ON L6H 5R4
 TEL: 1-888-238-7665

⚠ WARNING -- This product should be installed and serviced only by a qualified professional.

⚠ CAUTION -- A Licensed electrician **MUST** complete, in full, all electrical installations noted in this manual.

Use of non-Hayward replacement parts voids warranty.

ATTENTION INSTALLER - THIS MANUAL CONTAINS IMPORTANT INFORMATION ABOUT THE INSTALLATION, OPERATION, AND SAFE USE OF THIS PUMP THAT MUST BE FURNISHED TO THE END USER OF THIS PRODUCT. FAILURE TO READ AND FOLLOW ALL INSTRUCTIONS COULD RESULT IN SERIOUS INJURY.



⚠ WARNING - Read and follow all instructions in this owner's manual and on the equipment. Failure to follow instructions can cause severe injury and/or death.

IMPORTANT SAFETY INSTRUCTIONS

Before installing or servicing this electrical equipment, turn power supply **OFF**.

Basic safety precautions should always be followed, including the following: Failure to follow instructions may result in injury.

⚠ This is the safety-alert symbol. When you see this symbol on your pump or in this manual, look for one of the following signal words and be alert to the potential for personal injury.

⚠ DANGER warns about hazards that **will** cause serious potential injury, death or major property damage and if ignored presents an imminent hazard.

⚠ WARNING warns about hazards that **could** cause serious personal injury, death or major property damage and if ignored presents a potential hazard.

⚠ CAUTION warns about hazards that **will** or **can** cause minor or moderate personal injury and/or property damage and if ignored presents a potential hazard. It can also make consumers aware of actions that are unpredictable and unsafe.

The **NOTICE** label indicated special instructions that are important but not related to hazards.

⚠ WARNING - To reduce risk of injury, do not permit children to use or climb on this product. Closely supervise children at all times. Components such as the filtration system, pumps, and heaters must be positioned to prevent children from using them as means of access to the pool.

⚠ CAUTION - This pump is intended for use on permanently installed swimming pools and may also be used with hot tubs and spas if so marked. Do NOT use with storable pools. A permanently installed pool is constructed in or on the ground or in a building such that it cannot be readily disassembled for storage. A storable pool is constructed so that it is capable of being readily disassembled for storage and reassembled to its original integrity. Though this product is designed for outdoor use, it is strongly advised to protect the electrical components from the weather. Select a well-drained area, one that will not flood when it rains. It requires free circulation of air for cooling. Do not install in a damp or non-ventilated location. If installed within an outer enclosure or beneath a skirt of a hot tub or spa, adequate ventilation and free circulation of air must be provided to prevent overheating of the motor.

⚠ WARNING - Pool and spa components have a finite life. All components should be inspected frequently and replaced at least every ten years, or if found to be damaged, broken, cracked, missing, or not securely attached.



⚠ WARNING - Risk of Electrical Shock. It is required that licensed electricians do all the electrical wiring. Hazardous voltage. Can shock, burn, or cause death. To reduce the risk of electrical shock, do NOT use an extension cord to connect unit to electric supply. Provide properly located outlet. All electrical wiring MUST be in conformance with applicable local and national codes and regulations. Before working on pump or motor, disconnect motor wiring.

⚠ WARNING - To reduce the risk of electrical shock replace damaged cord immediately. Do NOT bury cord. Locate cord to prevent abuse from lawn mowers, hedge trimmers and other equipment.

⚠ WARNING - Connect only to a grounding type receptacle protected by a Ground Fault Circuit Interrupter (GFCI). Contact a licensed electrician if you cannot verify that the receptacle is protected by a GFCI.

⚠ WARNING - Failure to bond pump to pool structure will increase risk of electrocution and could result in injury or death. To reduce the risk of electrical shock, see installation instructions and consult a professional electrician on how to bond pump. Also, contact a licensed electrician for information on local electrical codes for bonding requirements.

Use a solid copper conductor, size 6 or larger. Run continuous wire from external bonding lug to reinforcing rod or mesh. Connect a No. 6 AWG solid copper bonding wire to the pressure wire connector provided on the motor housing and to all metal parts of swimming pool, spa, or hot tub, and to all the electrical equipment, metal piping (except gas piping), and conduit within 5 ft. (1.5 m) of inside walls of swimming pool, spa, or hot tub. **IMPORTANT** - Reference Canadian Electrical Codes for all wiring standards including, but not limited to grounding, bonding and other general wiring procedures.

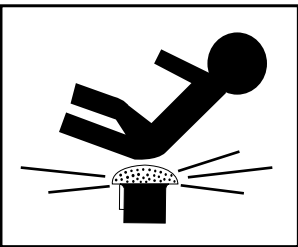

⚠ WARNING - Suction Entrapment Hazard.

Suction in suction outlets and/or suction outlet covers which are damaged, broken, cracked, missing, or unsecured cause severe injury and/or death due to the following entrapment hazards:

Hair Entrapment - Hair can become entangled in suction outlet cover.

Limb Entrapment - A limb inserted into an opening of a suction outlet sump or suction outlet cover that is damaged, broken, cracked, missing, or not securely attached can result in a medical bind or swelling of the limb.

Body Suction Entrapment - A differential pressure applied to a large portion of the body or limbs can result in an entrapment.

Evisceration/Disembowelment - A negative pressure applied directly to the intestines through an unprotected suction outlet sump or suction outlet cover which is damaged, broken, cracked, missing, or unsecured can result in evisceration/disembowelment.

Mechanical Entrapment - There is potential for jewelry, swimsuits, hair decorations, fingers, toes, or knuckles to be caught in an opening of a suction outlet cover resulting in mechanical entrapment.

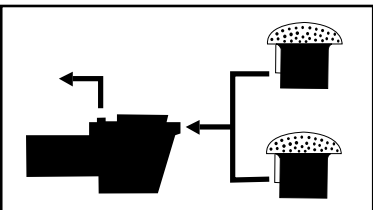

⚠ WARNING - To Reduce the risk of Entrapment Hazards:

- When outlets are small enough to be blocked by a person, a minimum of two functioning suction outlets per pump must be installed. Suction outlets in the same place (i.e. floor or wall), must be installed a minimum of three feet (3') [0.91 meter] apart, as measured from near point to near point.
- Dual suction fittings shall be placed in such locations and distanced to avoid "dual blockage" by a user.
- Dual suction fittings shall not be located on seating areas or on the backrest for such seating areas.

- The maximum system flow rate shall not exceed the values shown in the "Pipe Sizing Chart" found at the bottom of page 4 of this manual
- Never use pool or spa if any suction outlet component is damaged, broken, cracked, missing, or not securely attached.
- Replace damaged, broken, cracked, missing, or not securely attached suction outlet components immediately.
- In addition to two or more suction outlets per pump installed in accordance with the latest IAF (formerly NSPI) standards and CPSC guidelines, follow all national, state, and local codes applicable.
- Installation of a vacuum release or vent system, which relieves entrapping suction, is recommended.

Product Specifications

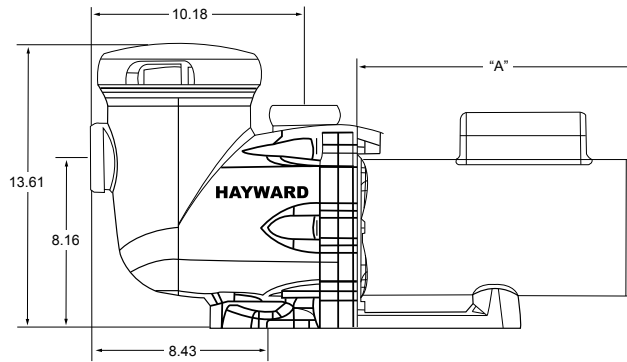
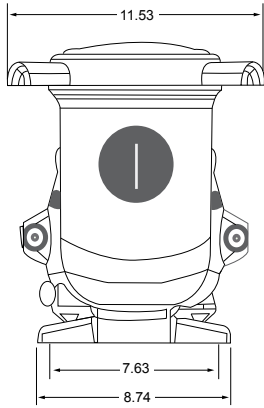

HP Rating	Length "A"
3/4	12-3/32"
1	12-19/32"
1 1/2	13-3/32"
2	13-3/32"
3	15-3/32"

Installation Instructions

⚠ WARNING - This product should be installed and serviced only by a qualified professional.

Pump Location

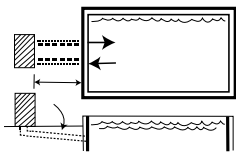

Locate pump as close to pool as practical and run suction lines as direct as possible to reduce friction loss. Suction lines should have continuous slope upwards from lowest point in line. Joints must be tight (but not over-tightened). Suction line diameter must equal or be larger than the discharge diameter.

Though the pump is designed for outdoor use, it is strongly advised to protect the electrical components from the weather. Select a well-drained area, one that will not flood when it rains. **Do NOT install pump in a damp or non-ventilated location.** Keep motor clean. Pump motors require free circulation from air for cooling.

Pump Mounting

Install pump on a firm, level base or pad to meet all local and national codes. Fasten pump to base or pad with screws or bolts to further reduce vibration and stress on pipe or hose joints. The base **MUST** be solid, level, rigid, and vibration free.

Pump mount must:

- Allow pump inlet height to be as close to water level as possible.
- Allow use of short, direct suction pipe (to reduce friction losses).
- Allow for gate valves in suction and discharge piping.
- Be protected from excess moisture and flooding.
- Allow adequate access for servicing pump and piping.

Pipe Sizing Chart

MAXIMUM RECOMMENDED SYSTEM FLOW RATE BY PIPE SIZE								
Pipe Size [mm]	Flow Rate GPM [LPM]	Suction Pipe Length *	Pipe Size [mm]	Flow Rate GPM [LPM]	Suction Pipe Length *	Pipe Size [mm]	Flow Rate GPM [LPM]	Suction Pipe Length *
1" [32]	20 [75]	5"	1 1/2" [50]	45 [170]	7 1/2"	2 1/2" [75]	110 [415]	12 1/2"
1 1/4" [40]	30 [110]	6 1/4"	2" [63]	80 [300]	10"	3" [90]	160 [600]	15"

NOTE - It is recommended that a minimum length of piping, equivalent to 10 pipe diameters, be used between the pump suction inlet and any plumbing fittings.

Pump Mounting (cont'd.)

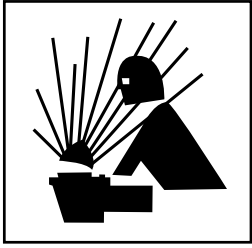

⚠ WARNING - Hazardous Pressure. Pumps, filters, and other equipment/components of a swimming pool filtration system operate under pressure. Incorrectly installed and/or improperly tested filtration equipment and/or components may fail resulting in injury and/or property damage.

Plumbing

Use Teflon tape to seal threaded connections on molded plastic components. All plastic fittings must be new or thoroughly cleaned before use. **NOTE - Do NOT use Plumber's Pipe Dope as it may cause cracking to the plastic components.** When applying Teflon tape to plastic threads, wrap the entire threaded portion of the male fitting with one to two layers of tape. Wind the tape clockwise as you face the open end of the fitting, beginning at the end of the fitting. The pump suction and outlet ports have molded-in thread stops. Do NOT attempt to force hose connector fitting past this stop. It is only necessary to tighten fittings enough to prevent leakage. Tighten fitting by hand and then use a tool to engage fitting an additional 1 ½ turns. Use care when using Teflon tape as friction is reduced considerable; **do NOT over-tighten fitting or you may cause damage.** If leaks occur, remove connector, clean off old Teflon tape, re-wrap with one or two additional layers of Teflon tape, and re-install connector.

Fittings

Fittings restrict flow. For better efficiency, use the fewest possible fittings (but at least two suction outlets). Avoid fittings that could cause an air trap. Pool and spa fittings MUST conform to the International Association of Plumbing and Mechanical Officials (IAPMO) standards. Use a non-entrapping suction fitting in pool (multiple drains) or double suction (skimmer and main drain).

Electrical



⚠ WARNING - Ground and bond motor before connecting to electrical power supply. Failure to ground and bond pump motor can cause serious or fatal electrical shock hazard.

⚠ WARNING - Do NOT ground to a gas supply line.

⚠ WARNING - To avoid dangerous or fatal electrical shock, turn OFF power to motor before working on electrical connections.

⚠ WARNING - Ground Fault Circuit Interrupter (GFCI) tripping indicates electrical problem. If GFCI trips and wont reset, consult electrician to inspect and repair electrical system.

⚠ WARNING - Fire Hazard. Match supply voltage to motor nameplate voltage.

Insure that the electrical supply available agrees with the motor's voltage, phase, and cycle, and that the wire size is adequate for the H.P. (KW) rating and distance from the power source. **NOTE - All electrical wiring MUST be performed by a licensed electrician, and MUST conform to local codes and Canadian Electrical Code regulations.** Use copper conductors only.

Motor Specifications

	Motor Brake Horsepower	Motor Rated Horsepower	Motor Electric V/A		Wire Size / Breaker	
	HP (kW)	HP (kW)	Voltage	Amps	AWG	Amps
Full Rate Pumps	1.13 (0.84)	0.50 (0.37)	208 - 230 / 115	5.3 - 4.9 / 9.8	14	10 / 15
	1.39 (1.04)	0.75 (0.56)	208 - 230 / 115	7.0 - 6.2 / 12.4	14	10 / 15
	1.85 (1.38)	1.00 (0.75)	208 - 230 / 115	8.5 - 7.4 / 14.8	14 / 12	15 / 20
	2.40 (1.79)	1.50 (1.12)	208 - 230 / 115	11.2 - 10.2 / 20.4	14 / 10	15 / 30
	2.70 (2.01)	2.00 (1.49)	208 - 230	11.8 - 11.0	14	15
	3.60 (2.69)	3.00 (2.24)	208 - 230	16.0 - 14.8	12	20
	3.60 (2.69) *	3.00 (2.24) *	208 - 230 / 460 *	9.6 - 9.4 / 4.7 *	14 *	15 / 10 *
	1.85 / 0.22 (1.38 / 0.16)	1.00 / 0.12 (0.75 / 0.09)	208 - 230	8.6 - 8.2 ¹	14	15
	2.40 / 0.28 (1.79 / 0.21)	1.50 / 0.18 (1.12 / 0.13)	208 - 230	11.4 - 10.4 ²	14	15
	2.70 / 0.33 (2.01 / 0.25)	2.00 / 0.25 (1.49 / 0.19)	208 - 230	12.4 - 11.2 ³	14	15
Max Rate Pumps	0.94 (0.70)	0.75 (0.56)		5.4 / 10.8	14	10 / 15
	1.25 (0.93)	1.00 (0.75)	230 / 115	7.0 / 14.0	14	10 / 15
	1.65 (1.23)	1.50 (1.12)	230 / 115	7.7 / 15.4	14 / 12	10 / 20
	2.20 (1.64)	2.00 (1.49)	230 / 115	10.8 / 21.6	14 / 10	15 / 30
	2.60 (1.94)	2.50 (1.86)	230	11.5	14	15
	3.45 (2.57)	3.00 (2.24)	230	13.5	14	15
	1.85 / 0.22 (1.38 / 0.16)	1.50 / 0.18 (1.12 / 0.13)	208 - 230	8.6 - 8.2 ¹	14	15
	2.40 / 0.28 (1.79 / 0.21)	2.00 / 0.25 (1.49 / 0.19)	208 - 230	11.4 - 10.4 ²	14	15
	2.70 / 0.33 (2.01 / 0.25)	2.50 / 0.31 (1.86 / 0.23)	208 - 230	12.4 - 11.2 ³	14	15

^{1, 2, 3} Low Speed Amps: (¹ 2.8 - 3.0) (² 3.2 - 3.4) (³ 3.8 - 4.1)

* Three-Phase (3Φ) Pump - motor starter required

Electrical (cont'd.)

Voltage

Voltage at motor **MUST NOT** be more than 10% above or below motor name plate rated voltage, or motor may overheat, causing overload tripping and reduced component life. If voltage is less than 90% or more than 110% of rated voltage when motor is running at full load, consult power company.

Grounding and Bonding

Install, ground, bond, and wire motor in accordance with local or Canadian Electrical Code requirements.

Permanently ground motor. Use green ground terminal provided under motor canopy or access plate; use size and type wire required by code. Connect motor ground terminal to electrical service ground.

Bond motor to pool structure. Bonding will connect all metal parts within and around the pool with a continuous wire. Bonding reduces the risk of a current passing between bonded metal objects, which could potentially cause electrical shock if grounded or shorted. **Reference Canadian Electrical Codes for all wiring standards including, but not limited to, grounding, bonding and general wiring procedures.**

Use a solid copper conductor, size 6 or larger. Run wire from external bonding lug to reinforcing rod or mesh. Connect a No. 6 AWG solid copper bonding wire to the pressure wire connector provided on the motor housing and to all metal parts of swimming pool, spa, or hot tub, and to all electrical equipment, metal piping (except gas piping), and conduit within 5 ft. (1.5 m) of inside walls of swimming pool, spa, or hot tub.

Wiring

⚠ WARNING - All wiring must be done by a licensed electrician.

Pump **MUST** be permanently connected to circuit. If other lights or appliances are also on the same circuit, be sure to add their amp loads before calculating wire and circuit breaker sizes. Use the load circuit breaker as the Master On-Off switch,

Install a Ground Fault Circuit Interrupter (GFCI) in circuit; it will sense a short-circuit to ground and disconnect power before it becomes dangerous to pool users. For size of GFCI required and test procedures for GFCI, see manufacturer's instructions. In case of a power outage, check GFCI for tripping, which will prevent normal pump operation. Reset if necessary.

575 V	Model #	Motor Break HorsePower HP (kW)	Motor Rated Horsepower HP (kW)	Service Factor	Motor Electric V/A		PH	Adjustable Thermal Range for Motor Overload Protection	
					Voltage	Amps			
	HCP3205C	1.0 (0.75)	0.5 (0.37)	2.0	575	1.15	3	2	4
	HCP3207C	1.39 (1.04)	0.75 (0.56)	1.85	575	1.8	3	2	4
	HCP3210C	1.9 (1.42)	1 (0.75)	1.9	575	2	3	2	4
	HCP3215C	2.4 (1.79)	1.5 (1.12)	1.6	575	2.9	3	4	6
	HCP3220C	2.8 (2.09)	2 (1.49)	1.4	575	3.1	3	4	6
	HCP3230C	3.6 (2.68)	3 (2.24)	1.2	575	4.2	3	4	6
	HCP3250C	5 (3.73)	5 (3.73)	1.0	575	5.2	3	4	6

Replacement Parts

Parts Diagram

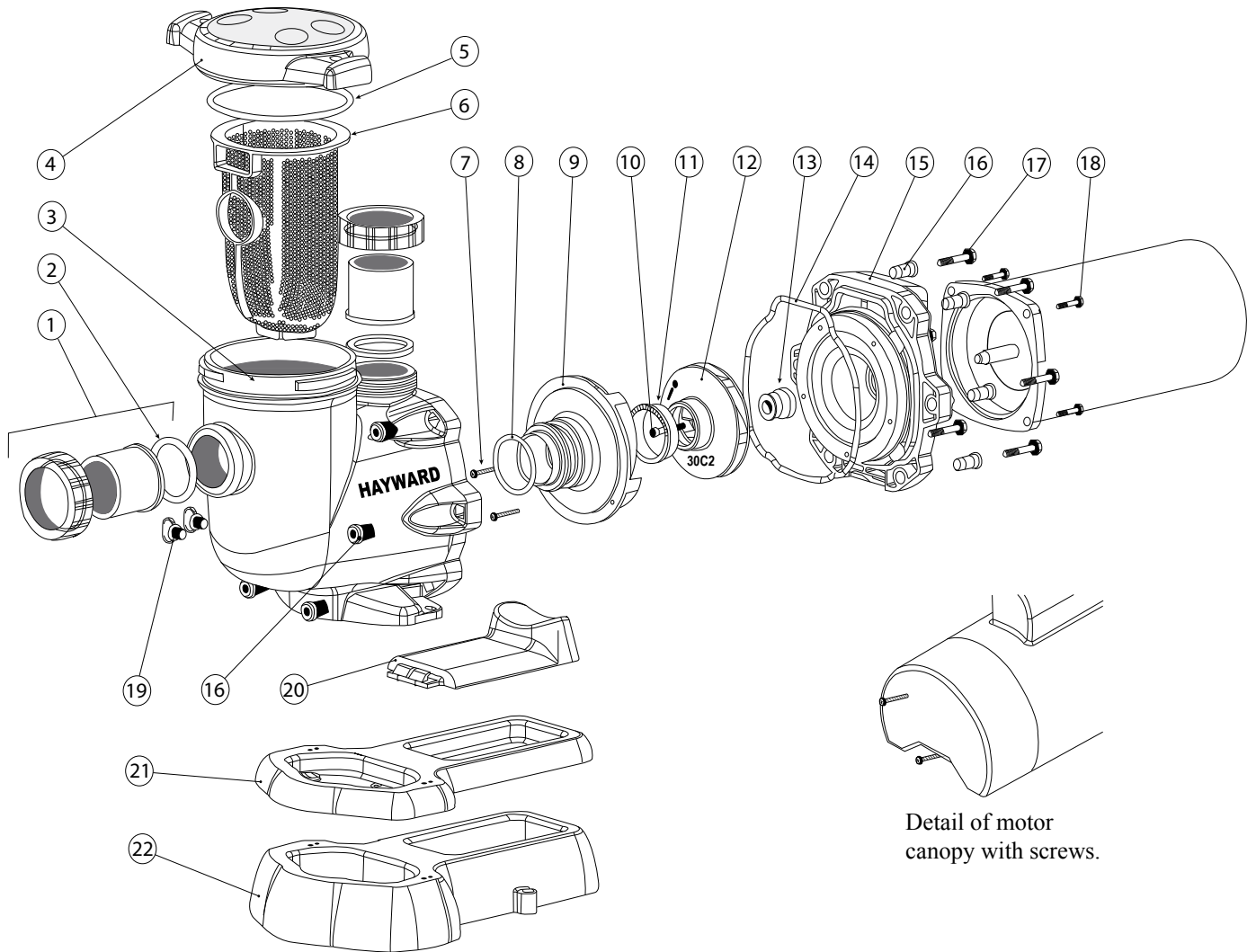

Parts Listing

Ref. No.	Part No.	Description	Ctn. Qty.
1	SPX3200UNKIT	Union Connector Kit (Nut, Connector, Gasket)	1
2	SPX3200UG	Union Gasket (T-seal), 50 duro EPDM	1
3	SPX3200A	Pump Strainer Housing, 2" x 2" with Drain Plugs, threaded style	1
4	SPX3200DLS	Strainer Cover Kit (Includes Strainer Lexan Cover, Lock Ring, O-Ring)	10
5	SPX3200S	Strainer Cover O-Ring	10
6	SPX3200M	Strainer Basket	15
7	SPX3200Z8	Diffuser Screw	1
8	SPX4000Z1	Diffuser O-Ring	10
9	SPX3200B3	Diffuser, 3 HP	1
10	SPX3200Z1	Impeller Screw	1
11	SPX3021R	Impeller Ring	1

Parts Listing (cont'd.)

Ref. No.	Part No.	Description	Ctn. Qty.
12	SPX3207C	Impeller for ¾ HP with Impeller Screw	10
	SPX3210C	Impeller for 1 HP with Impeller Screw	10
	SPX3215C	Impeller for 1 ½ HP with Impeller Screw	10
	SPX3220C	Impeller for 2 HP with Impeller Screw	10
	SPX3230C	Impeller for 3 HP with Impeller Screw	10
13	SPX3200SA	Shaft Seal Assembly	10
14	SPX3200T	Housing O-Ring	10
15	SPX3200E	Seal Plate	1
16	SPX3200Z211	Housing Insert & Seal Place Spacer Kit	1
17	SPX3200Z3	Housing Bolt	10
18	SPX3200Z5	Motor Bolt	1
19	SPX4000FG	Drain Plug with O-Ring	10
20	SPX3200GA	Motor support Bracket	1
21 *	SPX3200WF	Riser Base, Short	1
22 *	SPX3200SR	Riser Base, Tall	1

Pump SKU Detail

Model No.	Motor P/N	Impeller P/N
SP3205EE	SPX3205Z1BE	SPX3205C
SP3207EE	SPX3207Z1BE	SPX3207C
SP3210EE	SPX3210Z1BE	SPX3210C
SP3215EE	SPX3215Z1BE	SPX3215C
SP3220EE	SPX3220Z1BE	SPX3220C
SP3230EE	SPX3230Z1BE	SPX3230C
SP32102EE	SPX3210Z2BE	SPX3210C
SP32152EE	SPX3215Z2BE	SPX3215C
SP32202EE	SPX3220Z2BE	SPX3220C

575 VAC Commercial Pumps

Model No.	Motor P/N	Impeller P/N
HCP3205C	HCXP3205Z1DC	SPX3205C
HCP3207C	HCXP3207Z1DC	SPX3207C
HCP3210C	HCXP3210Z1DC	SPX3210C
HCP3215C	HCXP3215Z1DC	SPX3215C
HCP3220C	HCXP3220Z1DC	SPX3220C
HCP3230C	HCXP3230Z1DC	SPX3230C
HCP3250C	HCPX3250Z1DC	SPX3230C5