

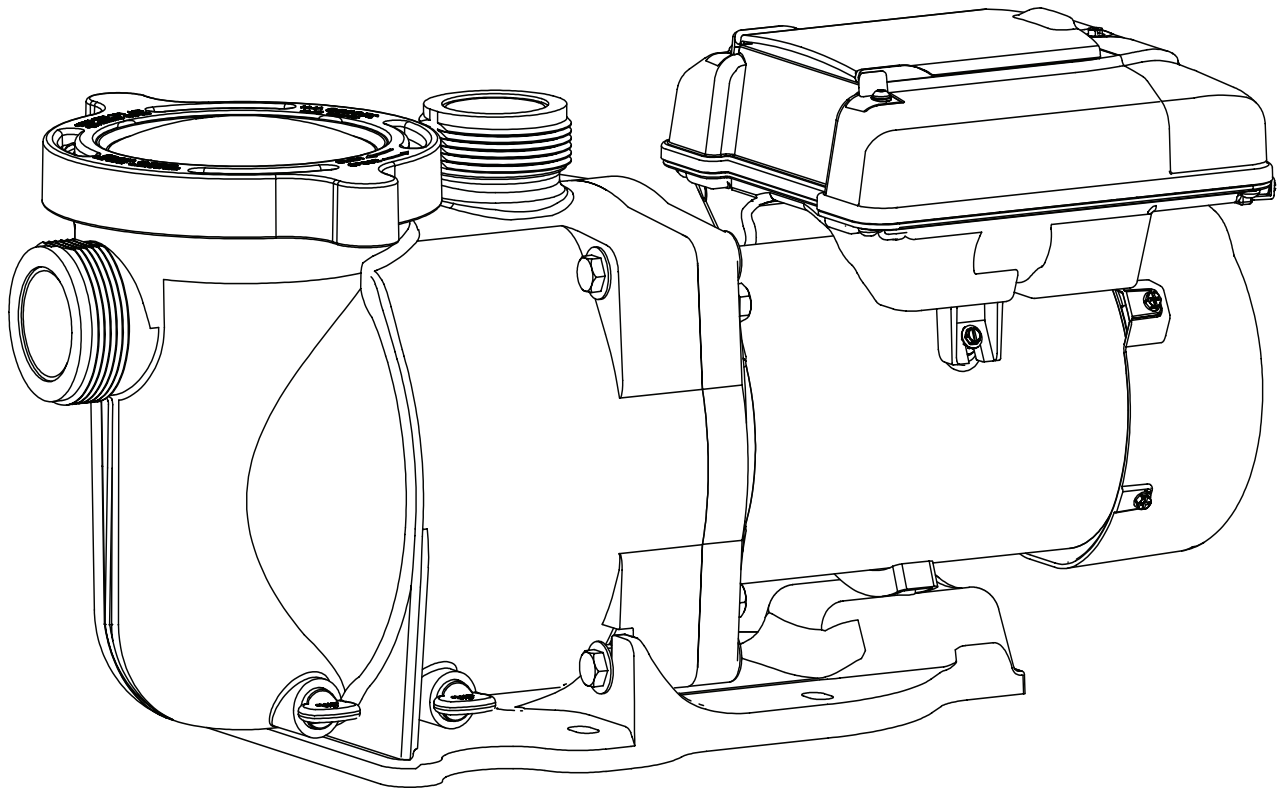

SUPERFLO[®] VS VARIABLE SPEED PUMP



INSTALLATION AND USER'S GUIDE



IMPORTANT SAFETY INSTRUCTIONS
READ AND FOLLOW ALL INSTRUCTIONS
SAVE THESE INSTRUCTIONS



CUSTOMER SERVICE / TECHNICAL SUPPORT

If you have questions about ordering Pentair Aquatic Systems replacement parts, and pool products, please contact:

Customer Service and Technical Support, USA

(8 A.M. to 4:30 P.M. — Eastern/Pacific Times)

Phone: (800) 831-7133

Fax: (800) 284-4151

Web site

Visit www.pentairpool.com or www.staritepool.com

Sanford, North Carolina (8 A.M. to 4:30 P.M. ET)

Phone: (919) 566-8000

Fax: (919) 566-8920

Moorpark, California (8 A.M. to 4:30 P.M. PT)

Phone: (805) 553-5000 (Ext. 5591)

Fax: (805) 553-5515

TABLE OF CONTENTS

Important Pump Warning and Safety Instructions	ii	Wiring Installation	11
Pump Overview	1	Wiring Overview	12
Pump Overview and Features	1	Control with Automation System Inputs	14
General Features	1	DIP Switches	14
Controller Features	1	Maintenance	15
Controller Overview	2	Pump Strainer Basket	15
Control Panel LEDs and Functions	3	Cleaning Pump Strainer Basket	15
Quick Start Guide	4	Winterizing	15
Factory Default Schedule	4	Servicing	16
User-Defined Schedule	4	Electric Motor Care	16
Control Panel Overview	5	Shaft Seal Replacement	16
Navigation	5	Pump Disassembly	16
Operating the Pump	6	Pump Reassembly	17
Keypad Overview	6	Restart Instructions	17
Setting a Schedule	6	Troubleshooting	18
Schedule Tables	6	Fault Status	20
Pump Operation from Control Panel	7	Replacement Parts	21
Override	8	Pump Performance Curves	22
Schedule Advance	8	Pump Specifications	22
Key Lockout	9	Pump Dimensions	22
Time Out	9		
Temporary Stop with Automation/Serial Input	9		
Reset Factory Defaults	10		
Priming	10		
Care and Maintenance	10		



IMPORTANT PUMP WARNING AND SAFETY INSTRUCTIONS



IMPORTANT NOTICE

This guide provides installation and operation instructions for the SuperFlo® VS Variable Speed Pump. Consult Pentair with any questions regarding this equipment.

Attention Installer: This guide contains important information about the installation, operation and safe use of this product. This information should be given to the owner and/or operator of this equipment after installation or left on or near the pump.

Attention User: This manual contains important information that will help you in operating and maintaining this product. Please retain it for future reference. Warnings and safety instructions for Pentair Aquatic Systems pumps and other related products are available at:

<http://www.pentairpool.com/pool-owner/safety-warnings/> or call (800) 831-7133 for additional free copies of these instructions.

READ AND FOLLOW ALL INSTRUCTIONS SAVE THESE INSTRUCTIONS



This is the safety alert symbol. When you see this symbol on your system or in this manual, look for one of the following signal words and be alert to the potential for personal injury.

⚠ DANGER

Warns about hazards that can cause death, serious personal injury, or major property damage if ignored.

⚠ WARNING

Warns about hazards that may cause death, serious personal injury, or major property damage if ignored.

⚠ CAUTION

Warns about hazards that may or can cause minor personal injury or property damage if ignored.

NOTE indicates special instructions not related to hazards.

Carefully read and follow all safety instructions in this manual and on equipment. Keep safety labels in good condition; replace if missing or damaged.

When installing and using this electrical equipment, basic safety precautions should always be followed, include the following:

⚠ WARNING Do not permit children to use this product.

⚠ WARNING RISK OF ELECTRICAL SHOCK. Connect only to a branch circuit protected by a ground-fault circuit-interrupter (GFCI). Contact a qualified electrician if you cannot verify that the circuit is protected by a GFCI.

⚠ WARNING This unit must be connected only to a supply circuit that is protected by a ground-fault circuit-interrupter (GFCI). Such a GFCI should be provided by the installer and should be tested on a routine basis. To test the GFCI, push the test button. The GFCI should interrupt power. Push the reset button. Power should be restored. If the GFCI fails to operate in this manner, the GFCI is defective. If the GFCI interrupts power to the pump without the test button being pushed, a ground current is flowing, indicating the possibility of an electric shock. Do not use this pump. Disconnect the pump and have the problem corrected by a qualified service representative before using.

⚠ CAUTION This pump is for use with permanent swimming pools and may also be used with hot tubs and spas if so marked. Do not use with storable pools. A permanently-installed pool is constructed in or on the ground or in a building such that it cannot be readily disassembled for storage. A storable pool is constructed so that it is capable of being readily disassembled for storage and reassembled to its original integrity.

General Warnings

- Never open the inside of the drive motor enclosure. There is a capacitor bank that holds a 230 VAC charge even when there is no power to the unit.
- The pump is not submersible.
- The pump is capable of high flow rates; use caution when installing and programming to limit pumps performance potential with old or questionable equipment.
- Code requirements for the electrical connection differ from state to state. Install equipment in accordance with the current National Electrical Code and all applicable local codes and ordinances.
- Before servicing the pump; switch OFF power to the pump by disconnecting the main circuit to the pump.
- This appliance is not intended for use by persons (including children) of reduced physical, sensory or mental capabilities, or lack of experience and knowledge, unless they have been given supervision or instruction concerning the use of the appliance by a person responsible for their safety.

⚠ DANGER FAILURE TO FOLLOW ALL INSTRUCTIONS AND WARNINGS CAN RESULT IN SERIOUS BODILY INJURY OR DEATH. **THIS PUMP SHOULD BE INSTALLED AND SERVICED ONLY BY A QUALIFIED POOL SERVICE PROFESSIONAL. INSTALLERS, POOL OPERATORS AND OWNERS MUST READ THESE WARNINGS AND ALL INSTRUCTIONS IN THE OWNER'S MANUAL BEFORE USING THIS PUMP. THESE WARNINGS AND THE OWNER'S MANUAL MUST BE LEFT WITH THE POOL OWNER.**

⚠ DANGER SUCTION ENTRAPMENT HAZARD: STAY OFF THE MAIN DRAIN AND AWAY FROM ALL SUCTION OUTLETS!



THIS PUMP PRODUCES HIGH LEVELS OF SUCTION AND CREATES A STRONG VACUUM AT THE MAIN DRAIN AT THE BOTTOM OF THE BODY OF WATER. THIS SUCTION IS SO STRONG THAT IT CAN TRAP ADULTS OR CHILDREN UNDER WATER IF THEY COME IN CLOSE PROXIMITY TO A DRAIN OR A LOOSE OR BROKEN DRAIN COVER OR GRATE.

⚠ DANGER RISK OF ELECTRICAL SHOCK OR ELECTROCUTION: PUMPS REQUIRE HIGH VOLTAGE WHICH CAN SHOCK, BURN, OR CAUSE DEATH. BEFORE WORKING ON PUMP! Always disconnect power to the pool pump at the circuit breaker from the pump before servicing the pump. Failure to do so could result in death or serious injury to service person, pool users or others due to electric shock.



THE USE OF UNAPPROVED COVERS OR ALLOWING USE OF THE POOL OR SPA WHEN COVERS ARE MISSING, CRACKED OR BROKEN CAN RESULT IN BODY OR LIMB ENTRAPMENT, HAIR ENTANGLEMENT, BODY ENTRAPMENT, EVISCERATION AND/OR DEATH. The suction at a drain or outlet can cause:

Limb Entrapment: When a limb is sucked or inserted into an opening resulting in a mechanical bind or swelling. This hazard is present when a drain cover is missing, broken, loose, cracked or not properly secured.

Hair Entanglement: When the hair tangles or knots in the drain cover, trapping the swimmer underwater. This hazard is present when the flow rating of the cover is too small for the pump or pumps.

IMPORTANT PUMP WARNING AND SAFETY INSTRUCTIONS

Body Entrapment: When a portion of the body is held against the drain cover trapping the swimmer underwater. This hazard is present when the drain cover is missing, broken or the cover flow rating is not high enough for the pump or pumps.

Evisceration/Disembowelment: When a person sits on an open pool (particularly a child wading pool) or spa outlet and suction is applied directly to the intestines, causing severe intestinal damage. This hazard is present when the drain cover is missing, loose, cracked, or not properly secured.

Mechanical Entrapment: When jewelry, swimsuit, hair decorations, finger, toe or knuckle is caught in an opening of an outlet or drain cover. This hazard is present when the drain cover is missing, broken, loose, cracked, or not properly secured.

NOTE: ALL SUCTION PLUMBING MUST BE INSTALLED IN ACCORDANCE WITH THE LATEST NATIONAL AND LOCAL CODES, STANDARDS AND GUIDELINES.

WARNING TO MINIMIZE THE RISK OF INJURY DUE TO SUCTION ENTRAPMENT HAZARD:

- A properly installed and secured ANSI/ASME A112.19.8 approved anti-entrapment suction cover must be used for each drain.
- Each suction cover must be installed at least three (3') feet apart, as measured from the nearest point to nearest point.
- Regularly inspect all covers for cracks, damage and advanced weathering.
- If a cover becomes loose, cracked, damaged, broken or is missing, replace with an appropriate certified cover.
- Replace drain covers as necessary. Drain covers deteriorate over time due to exposure to sunlight and weather.
- Avoid getting hair, limbs or body in close proximity to any suction cover, pool drain or outlet.
- Disable suction outlets or reconfigure into return inlets.

WARNING A clearly labeled emergency shut-off switch for the pump must be in an easily accessible, obvious place. Make sure users know where it is and how to use it in case of emergency.

The Virginia Graeme Baker (VGB) Pool and Spa Safety Act creates new requirements for owners and operators of commercial swimming pools and spas.

Commercial pools or spas constructed on or after December 19, 2008, shall utilize:

(A) A multiple main drain system without isolation capability with suction outlet covers that meet ASME/ANSI A112.19.8a Suction Fittings for Use in Swimming Pools, Wading Pools, Spas, and Hot Tubs and either:

- (i) A safety vacuum release system (SVRS) meeting ASME/ANSI A112.19.17 Manufactured Safety Vacuum Release systems (SVRS) for Residential and Commercial Swimming Pool, Spa, Hot Tub, and Wading Pool Suction Systems and/or ASTM F2387 Standard Specification for Manufactured Safety Vacuum Release Systems (SVRS) for Swimming pools, Spas and Hot Tubs or
- (ii) A properly designed and tested suction-limiting vent system or
- (iii) An automatic pump shut-off system.

Commercial pools and spas constructed prior to December 19, 2008, with a single submerged suction outlet shall use a suction outlet cover that meets ASME/ANSI A112.19.8a and either:

- (A) A SVRS meeting ASME/ANSI A112.19.17 and/or ASTM F2387, or
- (B) A properly designed and tested suction-limiting vent system, or
- (C) An automatic pump shut-off system, or
- (D) Disabled submerged outlets, or
- (E) Suction outlets shall be reconfigured into return inlets.

For Installation of Electrical Controls at Equipment Pad (ON/OFF Switches, Timers and Automation Load Center)

CAUTION



Install all electrical controls at equipment pad, such as on/off switches, timers, and control systems, etc. to allow the operation (startup, shut-down, or servicing) of any pump or filter so the user does not place any portion of his/her body over or near the pump strainer lid, filter lid or valve closures. This installation should allow the user enough space to stand clear of the filter and pump during system start-up, shut down or servicing of the system filter.

DANGER



HAZARDOUS PRESSURE: STAND CLEAR OF PUMP AND FILTER DURING START UP

Circulation systems operate under high pressure. When any part of the circulating system (i.e. locking ring, pump, filter, valves, etc.) is serviced, air can enter the system and become pressurized.

Pressurized air can cause the pump housing cover, filter lid, and valves to violently separate which can result in severe personal injury or death. Filter tank lid and strainer cover must be properly secured to prevent violent separation. Stand clear of all circulation system equipment when turning on or starting up pump.

Before servicing equipment, make note of the filter pressure. Be sure that all controls are set to ensure the system cannot inadvertently start during service. Turn off all power to the pump. **IMPORTANT: Place filter manual air relief valve in the open position and wait for all pressure in the system to be relieved.**

Before starting the system, fully open the manual air relief valve and place all system valves in the "open" position to allow water to flow freely from the tank and back to the tank. Stand clear of all equipment and start the pump. **IMPORTANT: Do not close filter manual air relief valve until all pressure has been discharged from the valve and a steady stream of water appears.** Observe filter pressure gauge and be sure it is not higher than the pre-service condition.

General Installation Information

- All work must be performed by a qualified service professional, and must conform to all national, state, and local codes.
- Install to provide drainage of compartment for electrical components.
- These instructions contain information for a variety of pump models and therefore some instructions may not apply to a specific model. All models are intended for use in swimming pool applications. The pump will function correctly only if it is properly sized to the specific application and properly installed.

WARNING

Pumps improperly sized or installed or used in applications other than for which the pump was intended can result in severe personal injury or death. These risks may include but not be limited to electric shock, fire, flooding, suction entrapment or severe injury or property damage caused by a structural failure of the pump or other system component.

WARNING

The pump can produce high levels of suction within the suction side of the plumbing system. These high levels of suction can pose a risk if a person comes within the close proximity of the suction openings. A person can be seriously injured by this high level of vacuum or may become trapped and drown. It is absolutely critical that the suction plumbing be installed in accordance with the latest national and local codes for swimming pools.

SAVE THESE INSTRUCTIONS

PUMP OVERVIEW

Pump Overview

The perfect choice for all types of pools, the SuperFlo® VS Variable Speed Pump was specifically designed to be your best choice for a variety of in-ground pools.

Thick walled body parts, a heavy duty TEFC motor, and highly engineered hydraulics make this rugged and tested design perfect for any pool, spa, water feature, or fountain.

All pumps from Pentair Aquatic Systems incorporate innovative hydraulic engineering that has been refined for over 40 years. Compact, rugged, and easy to maintain, the SuperFlo VS pump will deliver years of reliable service.

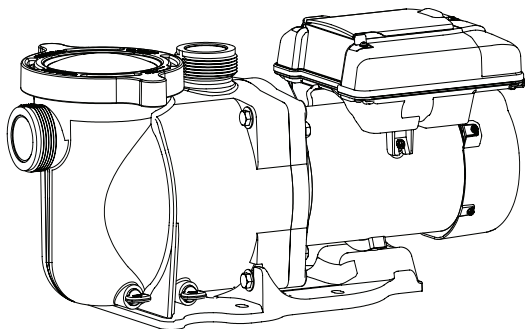

SuperFlo VS Pump

Pump Controller Features

- Simple user interface
- Motor design reduces noise emissions
- UV and rain-proof enclosure
- Manual OVERRIDE
- High efficiency electromechanical motor and control design

General Features

- Extremely quiet operation
- Unionized fittings (1.5" and 2") for simple replacement
- Cam and Ramp™ Lid for easy cleaning and maintenance
- Heavy-duty TEFC motor for long life
- Integral volute and pot reduce hydraulic noise
- See-through lid permits easy inspection of strainer basket
- Self-priming for quick, easy start-up
- UL/CUL/NSF Listed

Controller Overview

The SuperFlo® VS Variable Speed Pump uses a premium efficiency variable speed motor that provides tremendous program flexibility in terms of motor speed and duration settings. The pump is intended to run at the lowest speeds needed to maintain a sanitary environment, which in turn minimizes energy consumption. Pool size, the presence of additional water features, chemicals used to maintain sanitary conditions, and environmental factors will impact optimal programming necessary to maximize energy conservation.



WARNING This pump is for use with 208-230 Vrms nominal, and in pool pump applications ONLY. Connection to the wrong voltage, or use in other application may cause damage to equipment or personal injury.

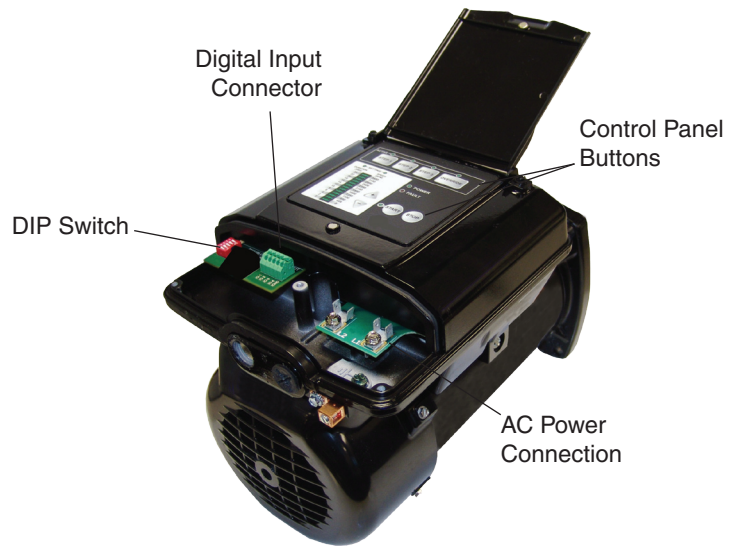

SuperFlo VS Pump

The integrated electronics interface controls the speed settings as well as the run durations. The pump can operate at speeds ranging between 600 and 3450 RPM and is rated for 208-230 Vrms at an input frequency of 60 Hz.

Program customization may require some trial-and-error to determine the most satisfactory settings as dictated by the conditions. In most cases, setting the pump at the lowest speed for the longest duration is the best strategy to minimize energy consumption. However, conditions may require running the pump at a higher speed for some duration of time each day to maintain proper filtration to achieve satisfactory sanitation.

The control panel key pad is located on top of the pump. To the right of the STEP buttons is the OVERRIDE button. Use this button to operate the pump at speeds outside of the normal operating schedule.

Note: Optimize the pump to suit individual pool conditions. Specific conditions including pool size, other devices, features and environmental factors can all impact the optimal settings.

Control Panel LEDs and Function Overview

LED Indication and Functionality Table

Key for LEDs	
X	Solid ON Indication
*	Blinking @ 1 sec
**	Alternates between DURATION and SPEED
#	Blink for three times @ 1 sec

LED → Function ↓	Power	START	FAULT	STEP1	STEP2	STEP3	OVERRIDE	SPEED SETTING	DURATION SETTING	BARGRAPH
Power On	X									
Keypad Functions										
Step1	X	X		X				**	**	**
Step2	X	X			X			**	**	**
Step3	X	X				X		**	**	**
Override	X	X					X	**	**	**
Keypad lock	X			*	*	*				
Keypad Unlock	X			X	X	X				
Schedule Advance	X	*							X	X
Restore Default settings	X									# (All LED)
Motor pause	X	*					*	X		X
Temporary stop	X									* (0 RPM)
Digital Input Functions										
DI1 ON	X			*				X		X
DI2 ON	X				*			X		X
DI3 ON	X					*		X		X
DI4 ON	X						*	X		X
Serial Communication Functions										
Serial Communication	X							*		
Motor spinning	X							*		X
Fault Handling										
UI fault	X		*							
Controller fault	X		X							

QUICK START GUIDE

Quick Start Instruction

CAUTION If power is connected to the SuperFlo® VS Variable Speed Pump motor, pressing any of the following buttons referred to in the following section could result in the motor starting. Failure to recognize this could result in personal injury or damage to equipment.

Using the factory default schedule

The following table describes the factory default settings for DURATION and SPEED order:

Button	Duration (In Hours)	Speed (In RPM)
STEP 1	4	3100
STEP 2	4	2600
STEP 3	8	1600
OVERRIDE	2	3450

Pressing the START key will start the pump based on the factory default schedule.

NOTE: If power is cycled to the pump and the user does not press the STOP key, the pump will automatically start and run the programmed default schedule shown in the chart above. This feature ensures that the pump will re-start in the event of a power outage. The pump will start on STEP 1.

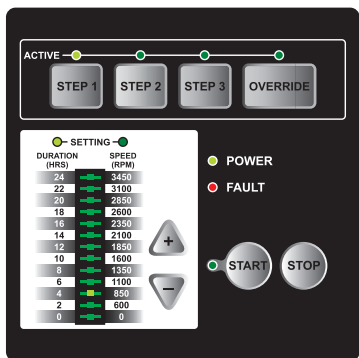

Figure 1: Duration LED

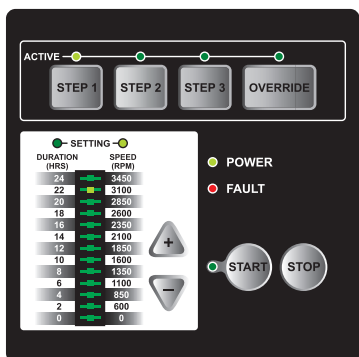

Figure 2: Speed LED

User-defined custom schedule

NOTE: The pump must be Stopped (Press STOP Key) when programming DURATION and SPEED of the STEP 1, STEP 2, and STEP 3 keys. OVERRIDE DURATION and SPEED can be programmed when the pump is either stopped or running.

To set the DURATION and SPEED for STEP 1, STEP 2, STEP 3 & OVERRIDE keys:

Press the STEP 1 key. The STEP 1 button and DURATION setting LEDs will illuminate. The bar graph will show default DURATION for STEP 1, see figure 1.

1. Press UP (+) or DOWN (-) arrows to change the DURATION.
2. Press the STEP 1 key again to change the SPEED setting. The SPEED setting LED will illuminate. The bar graph will show default SPEED for STEP 1, see figure 2.
3. Press UP (+) or DOWN (-) arrows to change the SPEED.
4. Press any STEP or OVERRIDE key to save the DURATION and SPEED settings for STEP 1. To revert back to the previously stored setting, press the STOP key.
5. Press STEP 2, STEP 3, or OVERRIDE key. Repeat steps 1-4 to program the corresponding DURATION and SPEED for each button.
6. Press START to run the pump based on the programmed 24 hour schedule.
7. To stop the pump, press the STOP button.

NOTE: The pump can only be set to operate on a 24-hour schedule. If a user attempts to program a schedule with a combined duration for all three steps greater than 24 hours, the pump software will retain the current STEP time duration only, and will zero out the other two STEP time settings. As an example, if STEP 1 equals eight (8) hours, STEP 2 equals nine (9) hours, and STEP 3 equals eight (8) hours – for a combined 25 hours – the pump will retain the setting for the current Step being programmed and zero out the remaining two. For details regarding the set-up of the three steps as part of a 24-hour schedule, see page 6.

NOTE: If using external devices it is the users responsibility to verify appropriate power and speed conditions. Refer to proper external device manual.

CONTROL PANEL OVERVIEW

Navigation Overview

- *+, - keys Increase/decrease selected value.*
- Pressing any key following a change accepts the current value displayed inside the setting.

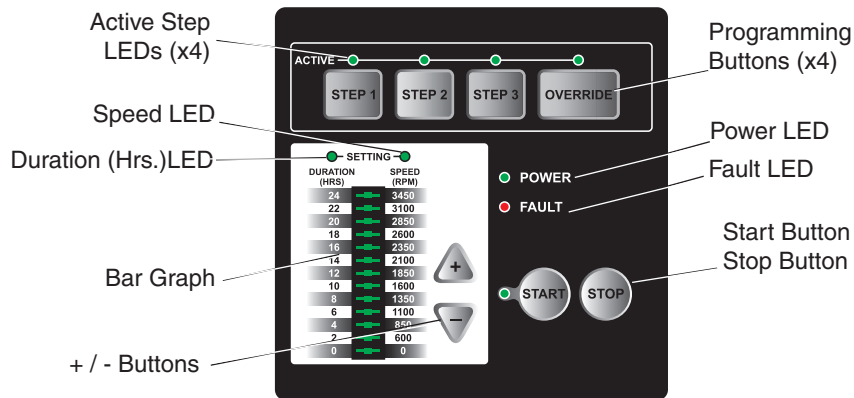

Figure 3: Control Panel

CAUTION

If power is connected to the SuperFlo® VS Variable Speed Pump motor, pressing any of the following buttons referred to in this section could result in the motor starting. Failure to recognize this could result in personal injury or damage to equipment.

Note: The START button must be pressed for the pump to operate. The START LED will illuminate after the button has been pressed indicating the pump is capable of operating. Pressing the stop button will turn off the START LED and stop the motor if running.

OPERATING THE PUMP

Keypad Overview



If power is connected to the SuperFlo® VS Variable Speed Pump motor, pressing any of the following buttons referred to in this section could result in the motor starting. Failure to recognize this could result in personal injury or damage to equipment.

1. **STEP 1 (Set Schedule)** → DURATION and SPEED
2. **STEP 2 (Set Schedule)** → DURATION and SPEED
3. **STEP 3 (Set Schedule)** → DURATION and SPEED
4. **OVERRIDE (Settings)** → DURATION and SPEED
5. **START**
6. **STOP**

Set a Schedule



If power is connected to the pump motor, pressing any of the following buttons referred to in this section could result in the motor starting. Failure to recognize this could result in personal injury or damage to equipment.

Set the DURATION and SPEED for the pump using the keys on the User Interface. The schedule is based on a 24-hour schedule and will repeat each day of the week.

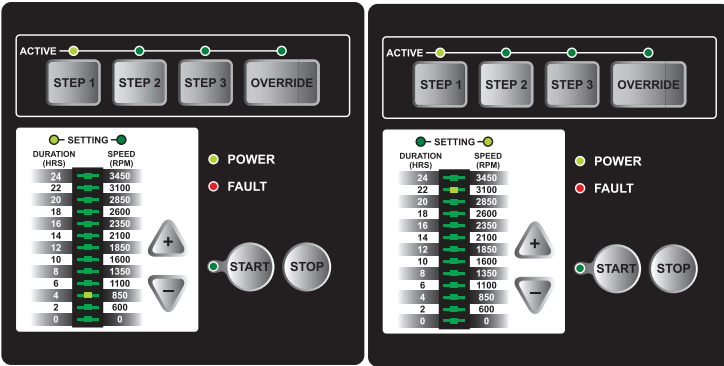

The highest speed rating for the pump is 3450 RPM and the lowest is 600 RPM. Unless a new user-defined schedule is entered, the pump will operate based on the following factory default schedule:

Button	Duration (In Hours)	Speed (In RPM)
STEP 1	4	3100
STEP 2	4	2600
STEP 3	8	1600
OVERRIDE	2	3450

Table 3: Factory default schedule

Schedule Tables

Use the tables below to record a personalized operating schedule. Recording the planned schedule in the table below will make the programming process easier and will help the user remember the custom settings in case of inadvertent loss of schedule. The user interface will not allow the user to program an overlap between different STEPs of the schedule. The STEP currently being set will always take priority over any previous settings. In the event a user attempts to program with a combined duration greater than 24 hours, the current STEP setting will be retained whereas the other two STEP settings will be cleared to zero hours requiring the user to reset them. Prior to beginning the actual programming process, it is advisable for the user to review the planned schedule as outlined in chart form to ensure the cumulative duration is not greater than 24 hours and no overlaps exist. It is always a good idea to double check your programmed settings for accuracy once you have completed the programming process.

Setup #1			
	Step 1	Step 2	Step 3
Duration			
Speed			

Setup #2			
	Step 1	Step 2	Step 3
Duration			
Speed			

Table 4: Custom Schedule

Operating the SuperFlo® VS Variable Speed Pump from the Control Panel

CAUTION

If power is connected to the pump motor, pressing any of the following buttons referred to in this section could result in the motor starting. Failure to recognize this could result in personal injury or damage to equipment.

1. Press the START key and the pump will run the programmed 24 hour duration schedule. The START event will be stored. Should a power outage occur, the pump will automatically re-start at STEP 1 when power is restored.
2. The pump will always run the PRIMING sequence when it starts from the OFF state, including when it automatically restarts following a power outage. The default Prime setting is defined in the “Priming” section, see page 10.
3. The pump then starts running in STEP 1 at the programmed DURATION and SPEED. The “ACTIVE LED” for STEP 1 will switch ON. The DURATION and SPEED setting LEDs along with the respective bar graph LED will blink back and forth every three (3) seconds.

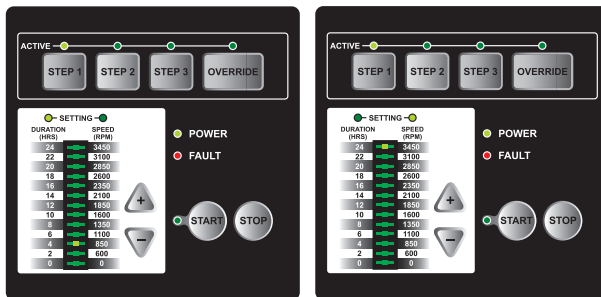

4. This sequence will then repeat for STEP 2 and then STEP 3 without the pump stopping.
5. At the end of STEP 3, the pump will wait if necessary for the completion of the 24-hour schedule. During this waiting period (if applicable), all of the “active step LEDs” will remain OFF. However, the START LED will still be illuminated. After completion of the 24 hour schedule, the system restarts at STEP 1 and this cycle will repeat indefinitely until the user presses the STOP key.

NOTE: Pressing a STEP key other than for the STEP currently running will cause an immediate transition to the newly selected STEP. The pump will continue with the programmed schedule from that point forward.

NOTE: If STOP is pressed during normal schedule operation, the 24 hour schedule will stop. When START is pressed again, the 24 hour schedule will start from STEP 1.

NOTE: If power is lost while the pump is running a 24 hour schedule, upon restoration of power the pump will start the 24 hour schedule from STEP 1.

NOTE: If an automation control system input (provided from an external source) is detected, the pump will start running on the STEP 1, STEP 2, STEP 3, or OVERRIDE speed corresponding to that automation input. Upon removing the automation input (provided from an external source), the pump will stop and the user will need to press START to begin the 24 hour schedule operation. However, if START was already pressed prior to receiving an automation input, then the pump will resume running the 24 hour schedule once the input is removed.

NOTE: Pressing STOP at any time turns the pump OFF and clears the start time for the 24 hour schedule.

Override

The SuperFlo® VS Variable Speed Pump is equipped with an OVERRIDE feature, which can be engaged to temporarily run at higher or lower speeds ranging between 600 to 3450 RPM. Once the OVERRIDE duration has elapsed, the pump will automatically return to the programmed schedule.

1. Pressing the OVERRIDE key while the pump is running will cause the pump to start running in the OVERRIDE mode at the programmed DURATION and SPEED. The “active LED” for OVERRIDE will illuminate. The DURATION and SPEED setting LEDs along with its respective bar graph LED will blink back and forth at three (3) second intervals.
2. The UP (+) / DOWN (-) arrows allow the user to configure OVER RIDE DURATION and SPEED. These settings can be changed while the pump is running. These settings are stored each time the UP (+) / DOWN (-) arrows are pressed.

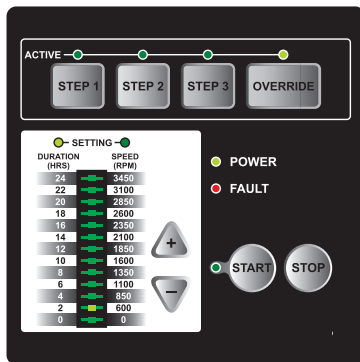

NOTE: When the OVERRIDE duration ends, the pump resumes the 24 hour schedule at the point in the currently programmed 24 hour schedule where it normally would be running at that time. The OVERRIDE duration will not affect the start or stop times of the 24 hour schedule. For example, if OVERRIDE runs during a period overlapping with a later part of STEP 1 and an early part of STEP 2, the start time of STEP 3 is not affected.

NOTE: Pressing/Holding OVERRIDE key for more than three (3) seconds will cancel OVERRIDE mode.

NOTE: During the OVERRIDE mode, the pump will not start with the priming sequence.

NOTE: It is recommended that you do not set the OVERRIDE duration to 0 HRS. Setting the OVERRIDE duration to 0 HRS will not allow you to change the duration setting while the motor is running. The motor will have to be stopped in order to change the OVERRIDE settings if the duration is set to 0 HRS.

Schedule Advance

The Schedule Advance mode allows the user to press the START button at one time of the day, with the 24-hour schedule starting at a different time of day. The pump can run in the Schedule Advance mode (by using the OVERRIDE button) and upon completion will begin the programmed 24 hour schedule at STEP 1 DURATION and SPEED.

The following steps should be followed to set Schedule Advance mode:

⚠ DANGER

Do not perform any maintenance on the motor while the motor is in Schedule Advance Mode. The motor may start without warning. This event could cause death or serious personal injury.

1. With the pump stopped, press and hold the START key for more than three (3) seconds. The START LED will blink at a rate of one second per pulse. The DURATION setting LED and respective bar graph LED will remain turned ON until the Schedule Advance mode is complete.
2. Press the UP (+) or DOWN (-) arrows to set the desired delay time after which the 24-hour schedule should start. The Schedule Advance mode will automatically start after the desired delay time is selected. The Schedule Advance mode can be cancelled by pressing the STOP key.

NOTE: The OVERRIDE button will still function when the Schedule Advance mode is active. This will allow the user to run the pump during the period of the Schedule Advance mode.

NOTE: While the pump is in the Schedule Advance mode, if a user presses STEP 1, STEP 2, STEP 3 or the START key, the system will start the normal schedule and the Schedule Advance mode will be canceled.

NOTE: While the pump is in the Schedule Advance mode, if a user presses the STOP key, then the Schedule Advance mode is canceled.

NOTE: If power is lost while the pump is in the Schedule Advance mode, then the 24-hour schedule will automatically start when power is restored.

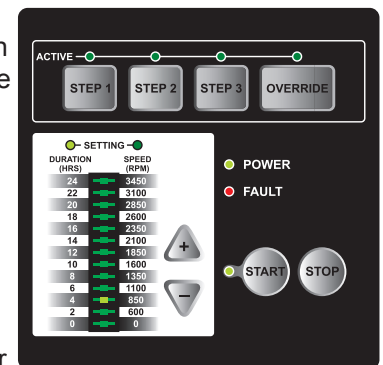

Key Lockout

CAUTION

Key lockout will not prevent the motor from being stopped by pressing the STOP button. If the motor is operating in “key lockout” mode, and being controlled through an automation input, the motor will only temporarily stop (4 min.) it will then restart.

The SuperFlo® VS Variable Speed Pump user interface has a “key lockout” feature to prevent unwanted changes to the settings.

To lock the keys, hold down the “STEP 1, STEP 2, and STEP 3” buttons all at the same time for at least three seconds. The “active LEDs” for STEP 1, STEP 2, and STEP 3 will blink for 30 seconds indicating that the keypad is locked.

The user can unlock the keys by holding down the same three STEP buttons for at least three seconds. The “active LEDs” for STEP 1, STEP 2, and STEP 3 will illuminate temporarily indicating the keypad is unlocked.

NOTE: While operating in “key lockout” mode the motor can still be stopped by pressing the stop key. If no input is present the motor will remain stopped. If the motor is being controlled by an automation control system input the motor will only temporarily stop for 4 minutes.

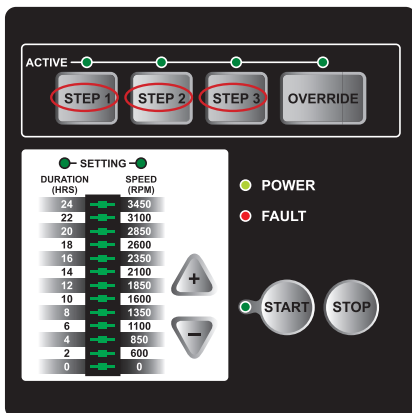

Time Out

The “time out” feature that will allow the user to temporarily stop the pump for maintenance work without disrupting the 24 hour schedule (i.e., for backwashing the filter). If the pump is currently running, the user can press and hold the START button for more than three (3) seconds and the pump will stop and remain off until the user presses and holds the START button again for more than three (3) seconds. The START and OVERRIDE buttons will blink once every second indicating that the “time out” feature is enabled. These LEDs will stop blinking once this feature is cancelled.

Temporary Stop with Automation Control System Input

CAUTION

Temporary stop functionality only works while the pump is being controlled by an automation input. If the motor is being controlled by the integrated key pad and STOP is pressed, the motor will stop and remain stopped.

The pump has a “temporary stop” feature that will immediately stop the pump when being controlled by an automation input. The user can press the STOP button while the pump is running and the pump will stop and stay off for four (4) minutes. Once this time has elapsed, the pump will return to normal operation and accept an input from an automation input source.

NOTE: If the pump is operating from automation input, the ‘0 RPM’ LED of the bar graph will blink once every second indicating the “temporary stop” feature has been activated. After the specified time period, the pump will return to normal operation and accept an input from any automation input source. Refer to page 14 for additional details on automation control system inputs.

Reset Factory Defaults

The SuperFlo® VS Variable Speed Pump user interface has a “Reset to Factory Defaults” feature to restore the schedule settings back to the original values programmed at the factory. The user must press and hold the STOP and OVERRIDE buttons for three (3) seconds to reset the settings back to factory defaults. All of the UI bar graph LED's will flash three (3) times to confirm the settings were restored to factory defaults.

Priming

The pump will always run the PRIMING sequence when starting from the OFF state, except when starting in OVERRIDE. The factory Prime settings are 3450 RPM for three (3) minutes.

Care and Maintenance

The pump is both reliable and robust in harsh environments. However, this product does contain electronics that are cooled by a fan mounted to the pump. In order to ensure optimum reliability of this product, it is recommended to clean the fan inlet on the back of the pump once a month. It is also important to keep this area free of large debris such as leaves, branches, mulch, plastic bags, etc.

ELECTRICAL WIRING INSTALLATION

⚠ WARNING



RISK OF ELECTRICAL SHOCK OR ELECTROCUTION. The SuperFlo® VS Variable Speed Pump must be installed by a licensed or certified electrician or a qualified service professional in accordance with the National Electrical Code and all applicable local codes and ordinances. Improper installation will create an electrical hazard which could result in death or serious injury to users, installers, or others due to electrical shock, and may also cause damage to property.

Always disconnect power to the pump at the circuit breaker before servicing the pump. Failure to do so could result in death or serious injury to service people, pool users or others due to electric shock and/or property damage.
Read all servicing instructions before working on the pump.

Wiring

1. Be sure all electrical breakers and switches are turned off before wiring motor.
2. Be sure that the wiring voltage matches the motor voltage (230 VAC). If they do not match, the motor can overheat.
3. Choose a wire size for the pump in accordance with the current National Electrical Code and all applicable local codes and ordinances. When in doubt use a heavier gauge (larger diameter) wire. Heavier gauge will allow the motor to run cooler and more efficient.
4. Be sure all electrical connections are clean and tight.
5. Cut wires to the appropriate length so they do not overlap or touch when connected to the terminal board.
6. Permanently ground the motor using the ground screw located on the inside rear of the controller interface, **see figure 4**. Use the correct wire size and type specified by the current National Electrical Code. Be sure the ground wire is connected to an electrical service ground.
7. Bond the motor to the pool structure in accordance with the current National Electrical Code. UL requires use of a solid copper bonding conductor not smaller than 8 AWG.
8. Connect the wire from the accessible wire connector on the motor to all metal parts of the swimming pool, spa, or hot tub structure and to all electrical equipment, metal conduit, and metal piping within 5 feet (1.5 M) of the inside walls of the swimming pool, spa, or hot tub. For Canada, a 6 AWG or larger solid copper bonding conductor is required.
9. The pump should be permanently connected to either a circuit breaker, 2-pole timer or 2-pole relay. If AC power is supplied by a GFCI circuit breaker, use a dedicated circuit breaker that has no other electrical loads.
10. Connect the pump permanently to a circuit. Make sure no other lights or appliances are on the same circuit.

Note: When pump is mounted permanently within 5 ft. (1.5 M) of the inside walls of a swimming pool, you must use a No. 8 AWG or larger conductor to connect to bonding conductor lug.

Note: When the pump is started and stopped by removing power with a relay or timer, a two-pole device should be used to apply and remove power to both POWER LINE TERMINALS.

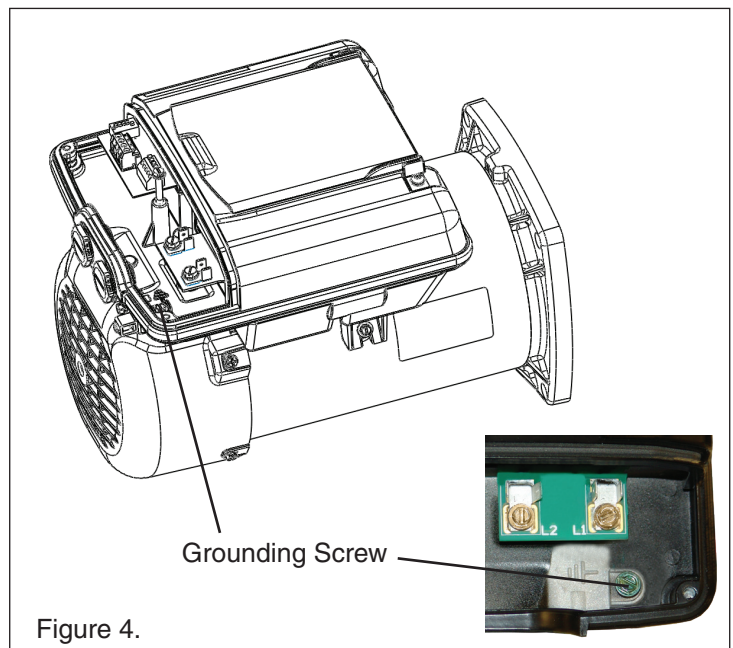

Figure 4.

Wiring

The SuperFlo® VS Variable Speed Pump controller must be wired according to the locally adopted version of the National Electrical Code. A licensed, qualified electrician should complete the wiring for this product.

The controller is designed to operate with 208-230 Vrms, single phase power.

The pump is designed to handle either a bare wire connection or a quick disconnect connection. The quick disconnect tab is 0.250" and will handle any commonly available mating connectors. For a direct wire connection, the wire insulation should be stripped to a length of approximately 0.33." The terminal block is capable of handling solid or stranded wire up to 12 AWG in size. The screw for the mains connections should be properly tightened to a torque value of 10 in-lb.

Pin #	Wire Color	Description
L1	Black	Hot 1
L2	Red or White	Hot 2
Ground screw	Green	Earth

Table 1: Main Connections

Pin #	Wire Color	Description
J201 - 1	Red	+12V
J201 - 2	Black	A
J201 - 3	Yellow	B
J201 - 4	Green	COM

Table 2: Communication Connections

⚠ WARNING

Power should be turned off when installing, servicing, or repairing electrical components. Observe all warning notices posted on the existing equipment, pump, and in these installation instructions.

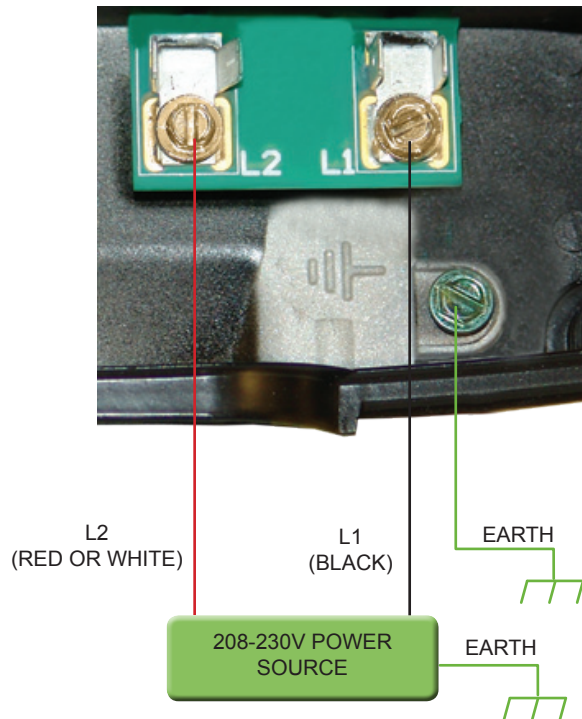

Figure 5: Main Connection Diagram

Pump Controller

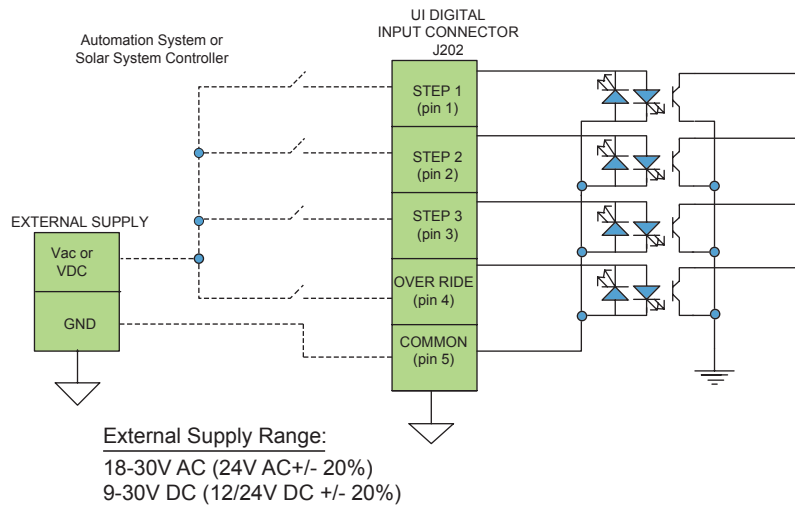

Figure 6: Wiring Diagram for Automation Control System Inputs

⚠ WARNING

Access to these terminals is in close proximity to the mains connectors which carry line voltage capable of causing personal injury or damaging the equipment if contact is made. Power should be turned off when accessing this area.

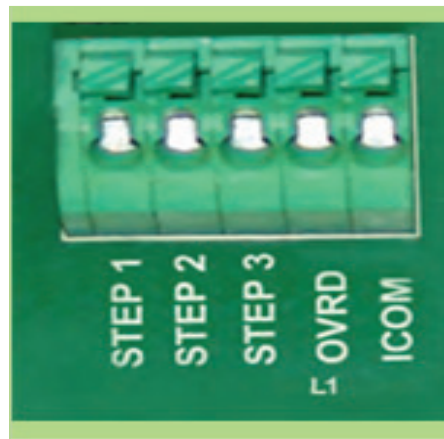

Figure 7: Automation Control System Input Connector

Control with Automation Control System Inputs

The user can run the SuperFlo® VS Variable Speed Pump at the programmed STEP 1, STEP 2, STEP 3, or OVERRIDE speeds by utilizing the four automation control system inputs. STEP 1, STEP 2, STEP 3, or OVERRIDE are equivalent to input 1, 2, 3 or OVRD respectively.

NOTE: The controller is rated to accept inputs of 18V-30V AC (24V AC +/- 20%) and 9-30V DC (12/24V DC +/- 20%).

NOTE: The pump will detect either a 50/60Hz for AC input or an active high signal for DC inputs.

The items below describe the functionality of the inputs:

1. If the user provides any one of the four (4) inputs, then the corresponding ACTIVE STEP LED will blink every one (1) second. The SPEED LED and corresponding bar graph LED will be illuminated to indicate the input is functioning properly.
2. The START LED will be OFF when an input is present.

⚠ WARNING

Access to these terminals is in close proximity to the mains connectors which carry line voltage capable of causing personal injury or damaging the equipment if contact is made. Power should be turned off when accessing this area.

NOTE: A generic wiring diagram is provided in **figure 6** (on page 13) for connecting the pump to an “Automation System Controller”. This concept can be applied to a solar system or any other type of control system.

NOTE: There is no schedule for automation system inputs. The timing for each speed is controlled directly by the inputs.

NOTE: The digital inputs have the highest priority amongst all inputs (i.e., keypad or digital). Therefore the User Interface inputs will be ignored when a digital input is present.

NOTE: If more than one input (switch) is present, then the pump will give priority to the highest number input. Therefore OVERRIDE has highest priority followed by STEP 3, then STEP 2, then STEP 1.

NOTE: If no automation input is detected, the pump will automatically start the 24 hour schedule if the START key was pressed prior to the application of an input.

NOTE: If using external devices it is the users responsibility to verify appropriate power and speed conditions. Refer to proper external device manual.

DIP Switches

The DIP switches are used for factory programming.

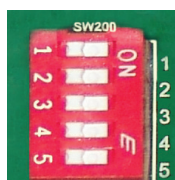

Figure 8: DIP Switches

MAINTENANCE



WARNING

DO NOT open the strainer pot if SuperFlo® VS Variable Speed Pump fails to prime or if pump has been operating without water in the strainer pot. Pumps operated in these circumstances may experience a build up of vapor pressure and may contain scalding hot water. Opening the pump may cause serious personal injury. In order to avoid the possibility of personal injury, make sure the suction and discharge valves are open and strainer pot temperature is cool to touch, then open with extreme caution.



CAUTION

To prevent damage to the pump and for proper operation of the system, clean pump strainer and skimmer baskets regularly.

Pump Strainer Basket

The pump strainer basket (or 'strainer pot', 'hair and lint pot'), is located in front of the volute. Inside the chamber is the basket which must be kept clean of leaves and debris at all times. View basket through the 'See Through Lid' to inspect for leaves and debris.

Regardless of the length of time between filter cleaning, it is most important to visually inspect the basket at least once a week. A dirty basket will reduce the efficiency of the filter and heater and also put an abnormal stress on the pump motor which would result in a costly repair bill.

Cleaning the Pump Strainer Basket

1. Turn off the pump at the circuit breaker.
2. Relieve pressure in the system by allowing the water to cool.
3. Gently tap the clamp in a counter-clockwise direction to remove the clamp and lid.
4. Remove debris and rinse out the basket. Replace the basket if it is cracked.
5. Put the basket back into the housing. Be sure to align the notch in the bottom of the basket with the rib in the bottom of the volute.
6. Fill the pump pot and volute up to the inlet port with water.
7. Clean the cover, O-ring, and sealing surface of the pump pot. **Note:** It is important to keep the lid O-ring clean and well lubricated.
8. Reinstall the lid by placing the lid on the pot. Be sure the lid O-ring is properly placed. Seat the clamp and lid on the pump then turn clockwise until the handles are horizontal.
9. Turn the power "ON" at the house circuit breaker. Reset the pool time clock to the correct time, if applicable.
10. Open the High Flow™ manual air relief valve on top of the filter.
11. Stand clear of the filter. Start the pump.
12. Bleed air from the filter until a steady stream of water comes out. Close the High Flow™ Manual Air Relief Valve.



WARNING

THIS SYSTEM OPERATES UNDER HIGH PRESSURE. When any part of the circulating system (e.g., Lock Ring, Pump, Filter, Valves, etc.) is serviced, air can enter the system and become pressurized. Pressurized air can cause the lid to separate which can result in serious injury, death, or property damage. To avoid this potential hazard, follow above instructions.



Winterizing

You are responsible for determining when freezing conditions may occur. If freezing conditions are expected, take the following steps to reduce the risk of freeze damage. **Freeze damage is not covered under warranty.**

To prevent freeze damage, follow the procedures below:

1. Shut off electrical power for the pump at the circuit breaker.
2. Drain the water out of the pump housing by removing the two thumb-twist drain plugs from the housing. Store the plugs in the pump basket.
3. Cover the motor to protect it from severe rain, snow and ice.

Note: Do not wrap motor with plastic or other air tight materials during winter storage. The motor may be covered during a storm, winter storage, etc., but never when operating or expecting operation.

Note: In mild climate areas, when temporary freezing conditions may occur, run your filtering equipment all night to prevent freezing.

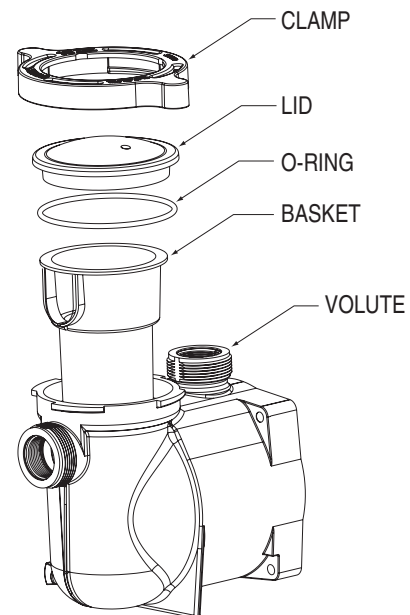

Strainer Pot Assembly

SERVICING



WARNING

Always disconnect power to the SuperFlo® VS Variable Speed Pump at the circuit breaker and disconnect the communication cable before servicing the pump. Failure to do so could result in death or serious injury to service people, users or others due to electric shock. Read all servicing instructions before working on the pump.



WARNING

DO NOT open the strainer pot if pump fails to prime or if pump has been operating without water in the strainer pot. Pumps operated in these circumstances may experience a build up of vapor pressure and may contain scalding hot water. Opening the pump may cause serious personal injury. In order to avoid the possibility of personal injury, make sure the suction and discharge valves are open and strainer pot temperature is cool to touch, then open with extreme caution.



CAUTION

Be sure not to scratch or mar the polished shaft seal faces; seal will leak if faces are damaged. The polished and lapped faces of the seal could be damaged if not handled with care.

Care of Electric Motor

Protect from heat

1. Shade the motor from the sun.
2. Any enclosure must be well ventilated to prevent overheating.
3. Provide ample cross ventilation.

Protect against dirt

1. Protect from any foreign matter.
2. Do not store (or spill) chemicals on or near the motor.
3. Avoid sweeping or stirring up dust near the motor while it is operating.
4. If a motor has been damaged by dirt it may void the motor warranty.
5. Clean the lid and clamp, O-ring, and sealing surface of the pump pot.

Protect against moisture

1. Protect from splashing or sprayed water.
2. Protect from extreme weather such as flooding.
3. If motor internals have become wet - let them dry before operating. Do not allow the pump to operate if it has been flooded.
4. If a motor has been damaged by water it may void the motor warranty.

Note: When replacing the motor, be certain that the motor support is correctly positioned to support the size of motor being installed.

Shaft Seal Replacement

The Shaft Seal consists primarily of two parts, a rotating member and a ceramic seal.

The pump requires little or no service other than reasonable care, however, a Shaft Seal may occasionally become damaged and must be replaced.

Note: The polished and lapped faces of the seal could be damaged if not handled with care.

Pump Disassembly

All moving parts are located in the rear sub-assembly of this pump.

Tools required:

- 1/4 inch socket or open end wrench.
- 3/8 inch socket or open end wrench.
- 9/16 inch open end wrench.
- 5/16 Allen Key
- Flat blade screwdriver.

To remove and repair the motor subassembly, follow the steps below:

1. Turn off the pump circuit breaker at the main panel.
2. Drain the pump by removing the drain plugs.
3. Remove the 4 bolts that hold the main pump body (strainer pot/volute) to the rear sub-assembly.
4. GENTLY pull the two pump halves apart, removing the rear sub-assembly.
5. Remove the three hex head screws holding the diffuser in position.
6. Hold the impeller securely in place and remove the impeller lock screw by using a flat blade screwdriver or wrench. The screw is a left-handed thread and loosens in a clockwise direction.
7. To unscrew the impeller from the shaft, insert a 5/16 Allen key into the center of the motor fan cover and twist the impeller counter-clockwise.
8. Remove the four bolts from the seal plate to the motor using a 3/8 inch wrench.
9. Place the seal plate face down on a flat surface and tap out the ceramic seal.
10. Clean the seal plate, seal housing, and the motor shaft.



DO NOT run the pump dry. If the pump is run dry, the mechanical seal will be damaged and the pump will start leaking. If this occurs, the damaged seal must be replaced. ALWAYS maintain proper water level. If the water level falls below the suction port, the pump will draw air through the suction port, losing the prime and causing the pump to run dry, resulting in a damaged seal. Continued operation in this manner could cause a loss of pressure, resulting in damage to the pump case, impeller and seal and may cause property damage and personal injury.

Pump Reassembly

1. When installing the replacement seal into the seal plate, use soapy water to wet the rubber boot before pressing it into the seal plate.
2. Remount the seal plate to the motor.
3. Before installing the rotating portion of the seal on the motor shaft, wet the motor shaft with soapy water and slide the seal onto the motor shaft. Ensure that the carbon face contacts the ceramic face of the stationary seat. Press the seal into the seal plate with your thumbs and wipe off the ceramic with a clean cloth.
4. Grease the motor shaft thread and screw impeller onto the motor shaft.
5. Screw in the impeller lock screw (counter-clockwise to tighten).
6. Remount the diffuser onto the seal plate. Make sure the plastic pins and holding screw inserts are aligned.
7. Grease the diffuser quad ring and seal plate O-ring prior to reassembly.
8. Grease the bolt threads, assemble the motor sub-assembly to the strainer pot-pump body by using the two through bolts for proper alignment. Do not tighten the through bolts until all 4 bolts are in place and finger tightened.
9. Fill the pump with water.
10. Reinstall the pump lid and plastic clamp; see the next section, 'Restart Instructions'.
11. Re-prime the system.

Restart Instructions

If SuperFlo® VS Variable Speed Pump is installed below the water level of the pool, close return and suction lines prior to opening hair and lint pot on pump. Make sure to re-open valves prior to operating.

Priming the Pump

The pump strainer pot must be filled with water before the pump is initially started.

Follow these steps to prime the pump:

1. Remove the pump lid plastic clamp. Remove the pump lid.
2. Fill the pump strainer pot with water.
3. Reassemble the pump cover and plastic clamp onto the strainer pot. The pump is now ready to prime.
4. Open the air release valve on the filter, and stand clear of the filter.
5. Turn on the switch or time clock.
6. When water comes out of the air release valve, close the valve. The system should now be free of air and recirculating water to and from the pool.

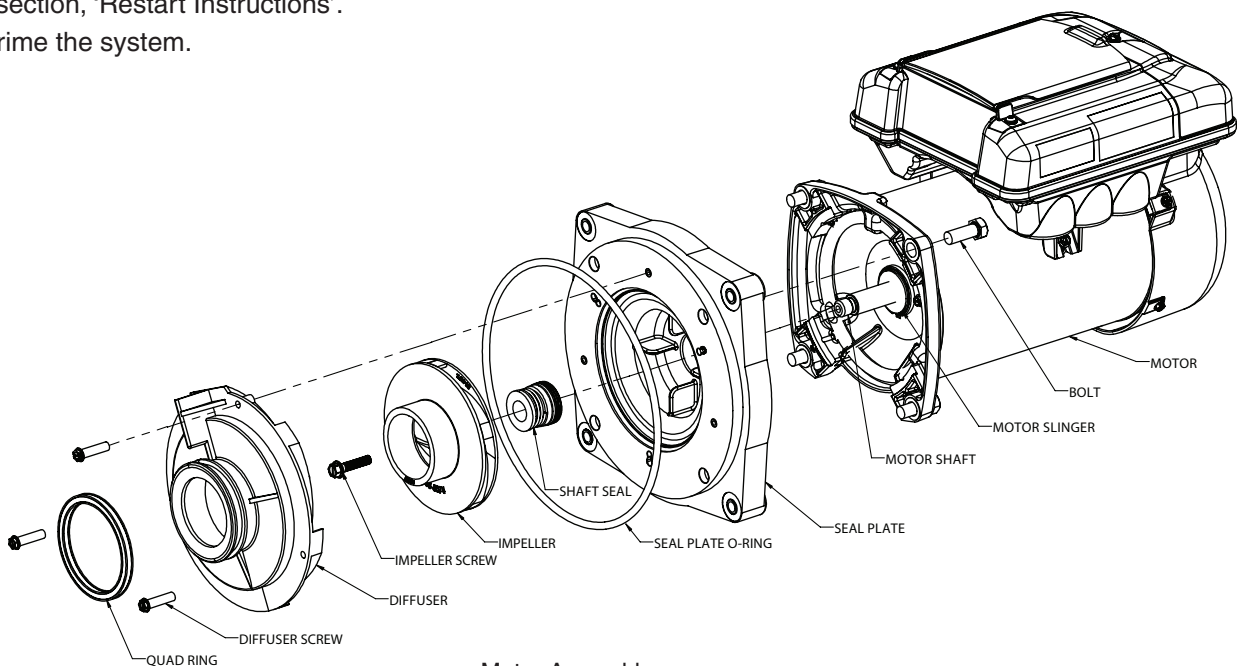

Motor Assembly

TROUBLESHOOTING

⚠ WARNING

Diagnosing certain symptoms may require close interaction with, or in close proximity to, components that are energized with electricity. Contact with electricity can cause death, personal injury, or property damage. When trouble shooting the pump, diagnostics involving electricity should be cared for by a licensed professional.

Problem	Possible Cause	Corrective Action
Pump failure.	<p>Pump will not prime - Air leak, too much air.</p> <p>Pump will not prime - Not enough water.</p> <p>Pump stainer gasket is clogged.</p> <p>Pump strainer gasket is defective.</p>	<p>Check suction piping and valve glands on any suction gate valves. Secure lid on pump strainer pot and be sure lid gasket is in place. Check water level to be sure skimmer is not drawing air.</p> <p>Be sure the suction lines, pump, strainer, and pump volute are full of water. Be sure valve on suction line is working and open (some systems do not have valves). Check water level to make sure water is available through skimmer.</p> <p>Clean pump strainer pot.</p> <p>Replace gasket.</p>
Reduced capacity and/or head.	<p>Air pockets or leaks in suction line.</p> <p>Clogged impeller.</p> <p>Pump strainer clogged.</p>	<p>Check suction piping and valve glands on any suction gate valves. Secure lid on pump strainer pot and be sure lid gasket is in place. Check water level to be sure skimmer is not drawing air.</p> <p>Turn off electrical power to the pump. Disassemble (see page 16, 'Pump Disassembly')</p> <p>Clean debris from impeller. If debris cannot be removed, complete the following steps: 1. Remove left hand thread anti-spin bolt and o-ring. 2. Remove, clean, and reinstall impeller. Reassemble (see page 17, 'Pump Reassembly')</p> <p>Clean suction trap.</p>
Pump fails to start.	<p>Mains Voltage is not present</p> <p>Pump shaft is locked</p> <p>Pump shaft is damaged</p>	<p>1. Replace fuse, reset breaker/GFCI. 2. Tighten mains wire connections.</p> <p>Check if the pump can be rotated by hand and remove any blockage.</p> <p>Replace pump.</p>
Pump runs then stops.	<p>Over temperature FAULT</p> <p>Over current FAULT</p>	<p>Check that back of pump is free from dirt and debris. Use compressed air to clean.</p> <p>Pump will automatically restart after one (1) minute.</p>
Pump is noisy.	<p>Debris in contact with fan</p> <p>Debris in strainer basket</p> <p>Loose mounting</p>	<p>Check that back of pump is free from dirt and debris. Use compressed air to clean.</p> <p>Clean strainer basket.</p> <p>Check that mounting bolts of pump and pump are tight.</p>

Troubleshooting (Cont.)

Problem	Possible Cause	Corrective Action
Pump runs without flow.	Impeller is loose Air leak Clogged or restricted plumbing	Check that pump is spinning by looking at fan on back of SuperFlo VS Variable Speed Pump. If so, check that pump impeller is correctly installed. Check plumbing connections and verify they are tight. Check for blockage in strainer or suction side piping. Checked for blockage in discharge piping including partially closed valve or dirty pool filter.

FAULT Status

**WARNING**

While the FAULT LED is illuminated the motor will not run, upon clearing the fault, the motor may automatically resume running depending on where in the schedule the FAULT occurred. This may cause personal injury or damage to the equipment.

The paragraphs below illustrate the possible faults that can occur with the SuperFlo® VS Variable Speed Pump. If the pump does not restart automatically following the FAULT, cycle AC power to the pump and wait five (5) minutes. If this does not correct the situation, please contact Customer Service at 1-800-831-7133.

The pump reads the FAULT status and provides feedback to the user via the FAULT LED. The pump will illuminate the FAULT LED when a FAULT is present. The pump will stop and remain OFF when the FAULT is present. Once the FAULT is cleared, if the pump was previously running, it will automatically resume running the normal schedule.

Below is the behavior of the FAULT LED when a FAULT is detected:

1. When a FAULT is present, and the motor is not running, only the FAULT LED and power LED will illuminate.
2. When a FAULT is present, and the motor is running, then the FAULT LED will illuminate. During the FAULT condition, the bar graph LEDs on the interface will turn OFF. However, the power LED, start LED & active STEP LED will remain illuminated.
3. When a FAULT is present and the FAULT LED is illuminated, only the STOP key will function. The remaining buttons become disabled.
4. When the FAULT LED is continuously ON (i.e. not blinking), a FAULT is present in the controller. When the FAULT LED is blinking every one (1) second, a FAULT is present in the user interface.
5. When the FAULT has cleared, the FAULT LED will turn OFF.
6. Once the FAULT is cleared, if the pump was previously running, it will automatically resume running the normal schedule.

Please see Troubleshooting (page 19) issues and their resolutions.

REPLACEMENT PARTS

SuperFlo® VS Variable Speed Pump Replacement Parts List

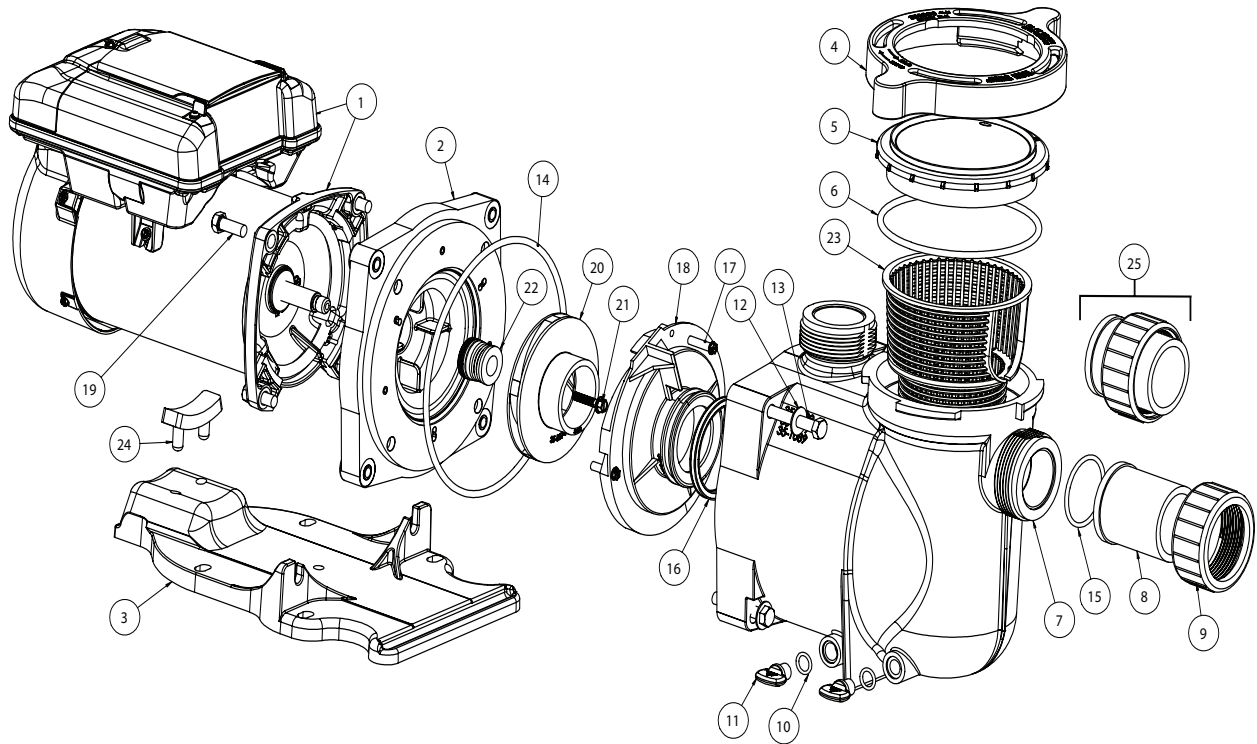

Item No.	Part No.	Description
1	358020Z	MOTOR / DRIVE
2	355612	SEAL PLATE
3	351094	BASE
4	351090	CLAMP, RAMP & CAM
5	350091	LID
6	357255	O-RING, LID #2-357
7	351089	VOLUTE
8	350093	ADAPTER, 2 req.
9	270141	NUT, 2 req.
10	192115	O-RING DRAIN PLUG, 2 req.
11	357161	DRAIN PLUG, 2 req.
12	072184	WASHER 3/8 in. S/S, 4 req.
13	355621	SCREW 3/4-16 X 2 1/4 HEX HD, 4 req.
14	355619	O-RING SEAL BRACKET
15	350099	O-RING ADAPTER #2-226, 2 req.
16	355030	SEAL DIFFUSER
17	355334	SCREW #8-32 HEX WASHER HD, 3 req.
18	355618	DIFFUSER
19	354290	HEX HEAD SCREW 3/8 - 16, 4 req.
20	355074	IMPELLER
21	355389	SCREW, IMPELLER LOCKING
22	354545	SEAL SET
23	355667	BASKET, LARGE
24	355385	MOTOR SUPPORT
25	350157	SUPERFLO UNION KIT(2 UNIONS, 2 ADAPTERS, 2 O-RINGS PER KIT)

Pump Performance Curves

SuperFlo® VS Variable Speed Pump

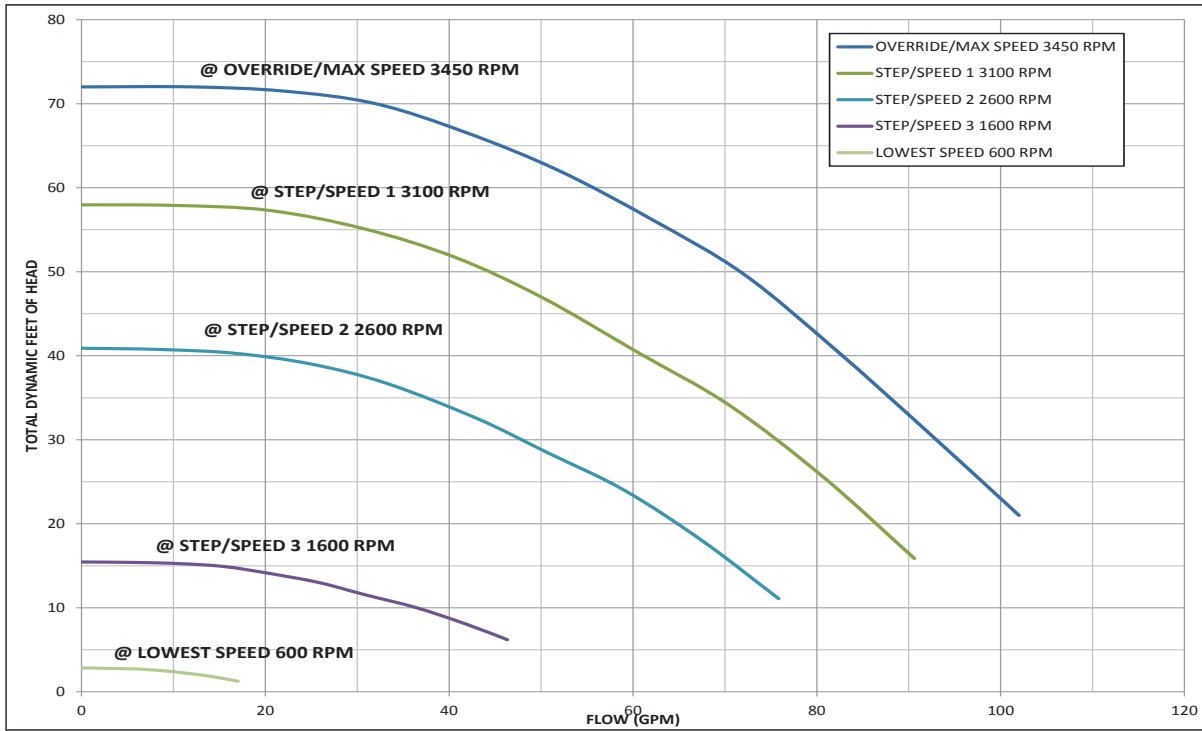

Specifications

Overall Ratings	
Input Voltage	208 - 230 Vrms nominal
Input Current	10.5 - 10.0 Arms
Input Frequency	Single phase, 60 Hz
Control Terminals	18-30V AC (24V AC +/- 20%) or 9-30V DC (12/24V DC +/- 20%)
Auxiliary Load Terminals	N/A
Maximum Continuous Load	1.65 THP (Total Horse Power)
Speed Range	600 - 3450 RPM
Environmental Rating	NEMA Type 3R
Agency Approval	R/C XDNW2.E302804 R/C XDNW8.E302804
UL US	
Ambient Conditions	
Storage	-40°C to +85°C (-40°F to +185°)
Operating	0°C to +50°C (+32°F to +122°F)
Humidity	Relative 0 to 95 % non-condensing

Pump Dimensions

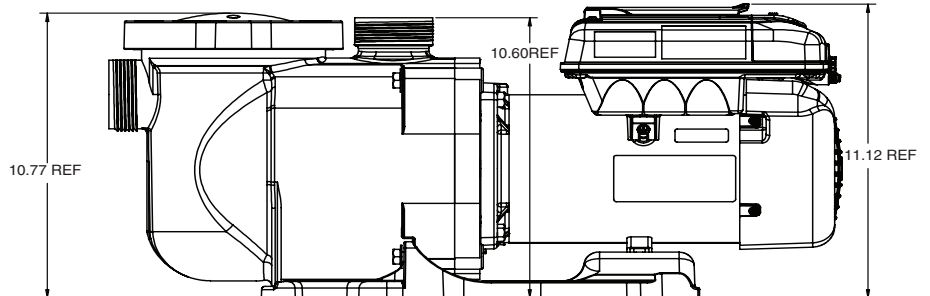
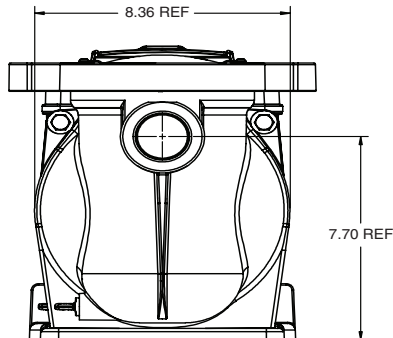
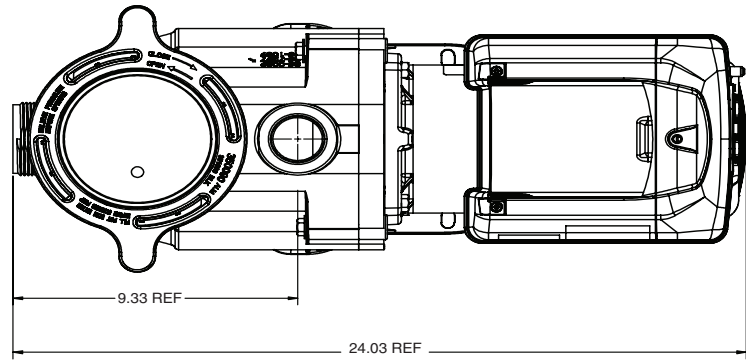



1620 HAWKINS AVE., SANFORD, NC 27330 • (919) 566-8000
10951 WEST LOS ANGELES AVE., MOORPARK, CA 93021 • (805) 553-5000

WWW.PENTAIRPOOL.COM

All Pentair trademarks and logos are owned by Pentair Inc. Pentair Aquatic Systems™, SuperFlo®, Eco-Select® and Cam and Ramp™ are trademarks and/or registered trademarks of Pentair Water Pool and Spa, Inc. and/or its affiliated companies in the United States and/or other countries. Unless expressly noted, names and brands of third parties that may be used in this document are not used to indicate an affiliation or endorsement between the owners of these names and brands and Pentair Water Pool and Spa, Inc. Those names and brands may be the trademarks or registered trademarks of those third parties. Because we are continuously improving our products and services, Pentair reserves the right to change specifications without prior notice. Pentair is an equal opportunity employer.

© 2013 Pentair Water Pool and Spa, Inc. All rights reserved. This document is subject to change without notice.



P/N 350880 REV. A 9/5/13