

SUBMERSIBLE PUMP

115V / 60HZ

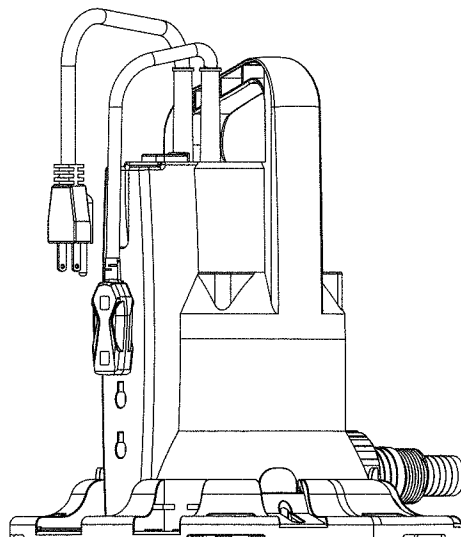

195096



Dear Customer,

We thank you for the trust you put in our products!

Your new appliance was designed and manufactured to the current state of the art.

Read these instructions for use carefully before using the appliance for the first time! These instructions contain all information necessary to safely use this appliance and provide for its extended lifespan. Please make sure to observe all safety information included in these instructions!

Table of contents

| | |
|----------------------------------|----|
| Before you begin... | 02 |
| For your safety | 03 |
| Your appliance at a glance | 04 |
| Operation | 04 |
| Cleaning and maintenance | 05 |
| Storing | 06 |
| Disposal | 06 |
| Malfunctions and troubleshooting | 06 |
| Technical data | 08 |
| Base plate assembling | 09 |

Before you begin...

Intended use

The appliance is intended for pumping rainwater, fresh water, and chlorinated swimming pool water.

It must not be used for the drinking water supply or for the delivery of foodstuffs.

Explosive, flammable, aggressive or health-hazardous substances and faecal matter must not be pumped.

Any use considered improper or Unpredictable: Damage can occur as a result of improper use, modifications to the appliance or due to the use of parts which have not been tested and approved by the manufacturer!

What do the symbols used mean?

Danger notices and information are clearly marked throughout these instructions for use. The following symbols are used:



Type and source of the danger!

Failure to observe this danger notice may cause physical injury or death.

For your safety



Type and source of the danger!

This danger notice warns of damage to the appliance, the environment or other property.



Note:

this symbol signifies information that may help you reach a better understanding of the processes involved.

GB

For your safety

General safety instructions

- To operate this appliance safely, the user must have read and understood these instructions for use before using the appliance for the first time.
- Always keep the operating instructions within reach.
- If you sell or pass the appliance on, you must also hand over these operating instructions.
- Observe all safety instructions! Failure to do so may cause harm to you and others.
- Do not use the appliance in potentially explosive areas or in the vicinity of flammable liquids or gases!
- Do not touch the power cord plug with wet hands! Always disconnect the power cord plug by pulling the plug and not the cable.
- The connection must be made to grounded sockets which have been properly installed and tested. Power voltage and fuse must comply with the technical data.
- During operation for swimming pools, garden ponds and similar places, the appliance must be equipped with a ground fault circuit breaker (GFCI) with a design fault current no more than 30 amp.
- Do not kink, crush, drag or drive over the power cable; protect against sharp edges, oil and heat.
- Extension cables must not be used.
- Disconnect the power plug before all work on the appliance.
- Do not install or switch on the appliance if there are people or animals in the medium being pumped (e. g. a swimming pool), or they are in contact with it.
- Children and young people under the age of 16 years, must not use this appliance and must be kept away from it when it is in operation.
- Repairs must be carried out only by a qualified electrician.
If repairs are carried out incorrectly, there is a danger of liquid penetrating the electrical components of the appliance.

Dear Customer,

We thank you for the trust you put in our products!

Your new appliance was designed and manufactured to the current state of the art.

Read these instructions for use carefully before using the appliance for the first time! These instructions contain all information necessary to safely use this appliance and provide for its extended lifespan. Please make sure to observe all safety information included in these instructions!

Table of contents

| | |
|----------------------------------|----|
| Before you begin... | 02 |
| For your safety | 03 |
| Your appliance at a glance | 04 |
| Operation | 04 |
| Cleaning and maintenance | 05 |
| Storing | 06 |
| Disposal | 06 |
| Malfunctions and troubleshooting | 06 |
| Technical data | 08 |
| Base plate assembling | 09 |

Before you begin...

Intended use

The appliance is intended for pumping rainwater, fresh water, and chlorinated swimming pool water.

It must not be used for the drinking water supply or for the delivery of foodstuffs.

Explosive, flammable, aggressive or health-hazardous substances and faecal matter must not be pumped.

Any use considered improper or Unpredictable: Damage can occur as a result of improper use, modifications to the appliance or due to the use of parts which have not been tested and approved by the manufacturer!

What do the symbols used mean?

Danger notices and information are clearly marked throughout these instructions for use. The following symbols are used:



Type and source of the danger!

Failure to observe this danger notice may cause physical injury or death.

For your safety



Type and source of the danger!

This danger notice warns of damage to the appliance, the environment or other property.



Note:

this symbol signifies information that may help you reach a better understanding of the processes involved.

GB

For your safety

General safety instructions

- To operate this appliance safely, the user must have read and understood these instructions for use before using the appliance for the first time.
- Always keep the operating instructions within reach.
- If you sell or pass the appliance on, you must also hand over these operating instructions.
- Observe all safety instructions! Failure to do so may cause harm to you and others.
- Do not use the appliance in potentially explosive areas or in the vicinity of flammable liquids or gases!
- Do not touch the power cord plug with wet hands! Always disconnect the power cord plug by pulling the plug and not the cable.
- The connection must be made to grounded sockets which have been properly installed and tested. Power voltage and fuse must comply with the technical data.
- During operation for swimming pools, garden ponds and similar places, the appliance must be equipped with a ground fault circuit breaker (GFCI) with a design fault current no more than 30 amp.
- Do not kink, crush, drag or drive over the power cable; protect against sharp edges, oil and heat.
- Extension cables must not be used.
- Disconnect the power plug before all work on the appliance.
- Do not install or switch on the appliance if there are people or animals in the medium being pumped (e. g. a swimming pool), or they are in contact with it.
- Children and young people under the age of 16 years, must not use this appliance and must be kept away from it when it is in operation.
- Repairs must be carried out only by a qualified electrician.
If repairs are carried out incorrectly, there is a danger of liquid penetrating the electrical components of the appliance.

Your appliance at a glance

1. Carrying handle
2. Power cable and plug
3. Sensor switch
4. Hose adapter
5. Pump casing
6. Sensor switch socket
- 6-1 Sensor position for continuous running
- 6-2 Sensor position for different pump starting water level
- 6-3 Sensor position for the lowest pump starting water level at 10mm.
7. Baseplate

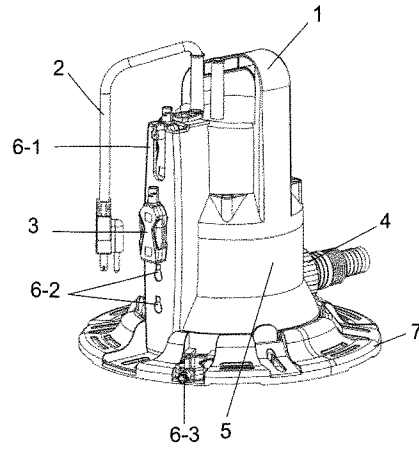

Operation

Installation

Attach a sufficiently long and strong rope to the specially designed bottom plate position before first use when the pump is placed onto the pool cover or attach the rope to the handle when the pump is to be used as a submersible pump.

Note:
The condition of the rope must be checked regularly for damage or decay.

Connect pressure hose or rigid pipe:

For occasional use, use a suitable water hose.

- Screw a garden hose onto the hose adapter.

All threaded connections must be sealed with thread sealing tape (e. g. Teflon® tape).

For non-threaded hose.

- Push the hose firmly onto the hose adapter and secure with a hose clamp.

The use of rigid pipes with a non-return valve is recommended for use at a fixed location. This prevents return flow of the liquid when pump is turned off.

Installation

The appliance can be used on the pool cover when the base plate is attached or submerged in the water container when the base plate is removed.

The appliance can be submerged under water up to the operating depth shown in the technical data.

When using as submersible pump, install the appliance so that the suction openings cannot be blocked by foreign bodies (place the appliance on a firm, even base).

Ensure that the appliance is stable.

Operation



Risk of damage to the appliance!

Do not lift the pump with the cable or pressure hose as these are not designed to support the weight of the pump.

- A. When using as a submersible pump
- Submerge the pump at an angle into the liquid so that no air pockets forms on the underside of the appliance. Suction would be prevented by this.
- A. When using as a submersible pump:
- Leave the pump on the bottom of the liquid container.
 - Use the rope attached to the carrying handle for lowering or raising.
 - Anchor the end of the rope after lowering appliance into the liquid container.



Note:

For operation with rope:

Do not operate the pump without pressure hose.

Avoid the pump twisting around its longitudinal axis.

- Adjust the position of sensor switch to choose the different pump starting water levels. (6-1 or 6-2)
 - This product has several vertical adjustment positions to allow pumping down to different depths.
- B. When using as a pool cover pump:
- Insure Base Plate and filter screen are attached.
 - Set water sensor at lowest pumping start position (6-3).
 - Attach rope per instructions.
 - Position the pump in the center of the pool cover.
 - Plug in the power cord per safety instructions.

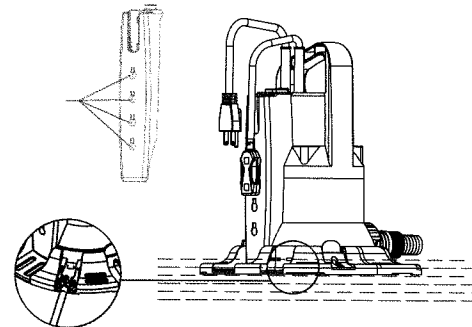

Cleaning and maintenance

Cleaning and maintenance overview

Before every use

- Check casing and power cord for damage.
- Check sensor switch for damage or corrosion.
- Check discharge hose or rigid pipe for leaks.
- Check rope for deterioration or fraying.

After every use

- Clean the appliance.
- Store in a safe dry location out of direct sunlight.

Cleaning the appliance externally

- Rinse with clean water. Remove stubborn contamination with a brush and detergent.
- Submerge the pump in a container with clean water and switch on for a short time to rinse the inside of the pump.

Cleaning the suction area

- Take off the base plate and filter screen, rinse the bottom of the pump with clean water. Remove stubborn contamination with a brush and detergent.

i Note:
Before using the pump again, "soak" it in clean water to remove any possible dirt residues that might block the underside of the appliance.

Storing

Dismantle the appliance and accessories, clean and store in a warm dry location.

! Attention! **Risk of damage to the appliance!**
Frost can harm the appliance and accessories, as water may get inside and freeze!

Disposal

Disposing of the appliance

 Products which are labelled with the adjacent symbol must not be disposed of with household trash. You must dispose of old electrical and electronic equipment properly.

Please check with your local authority for correct disposal procedures.

Disposing of the packaging

The packaging consists of cardboard and correspondingly marked plastics that can be recycled.

- Make these materials available for recycling.

Malfunctions and troubleshooting

In the event of a malfunction...

! Danger! **Danger of physical injury and death!**
Improperly conducted repairs may prevent your appliance from working safely. Such repairs may endanger you and your surroundings.

WARNING

Risk Of Electric Shock-This Pump Has Not Been Investigated For Use In Swimming Pool Or Marine Areas. To reduce risk of electric shock, connect only to a properly grounded, grounding-type receptacle. To Reduce the Risk Of Electric Shock, Install Only On A Circuit Protected By A Ground-Fault Circuit-Interrupter (GFCI).

Minor faults are often sufficient to cause a malfunction. In most cases, you will be able to correct these faults yourself. Please refer to the following table before contacting your retailer for technical support.

| Fault/malfunction | Cause | Remedy |
|------------------------------|---|--|
| Pump does not run. | No power voltage? | Check cables, plug, socket and fuse. |
| | Ground fault circuit interrupter triggered? | Reset GFCI Contact qualified electrician if GFCI triggers again. |
| | Motor defective? | Contact retailer or service contractor. |
| Pump runs but does not pump. | Suction openings blocked? | Clear blockage. |
| | Pump draws in air? | Keep the pump at an angle while submerging. Switch the pump on and off several times in order to expel air. |
| Delivery rate too low. | Pump blocked by foreign bodies? | Clean the pump (► Cleaning the suction area – p. 6). |
| | Pressure hose diameter too small? | Use pressure hose with larger diameter. |
| Pump runs very loudly. | Pressure hose blocked? | Clear blockage. |
| | Suction openings blocked? | Clean suction opening. |
| | Pressure hose kinked? | Straighten pressure hose. |
| | Pressure hose leaks? | Seal pressure hose, tighten threaded connections. |
| Motor overheats: | Liquid temperature too high? | Eliminate the cause of the overheating (max. temperature of liquid ► Technical data – p. 8). |
| | Blocking by foreign bodies? | |

If you are unable to correct a fault yourself, please contact your retailer for assistance. Please note that improperly conducted repairs will void your warranty.

! Attention! **Risk of damage to the appliance!**
The particle size mentioned does not refer to sand or stones but rather to soft, flexible particles which will not wedge inside the pump. Never allow the appliance to suck up sand or stones.

| | |
|---------------------------|-----------|
| Model | 195096 |
| Rated voltage/Frequency | 115V/60HZ |
| Power(HP) | 1/4 |
| Protection class | IPX8 |
| Max.submersible depth | 23 FT |
| Max.flow rate: | 2400FT |
| Max.head | 27FT |
| Max.temperature of liquid | 95°F |
| Pressure hose diameter | 3/4" |
| Pipe connection | 4/3" , 1" |
| Cable length | 33.3FT |
| Max.particle size | 5mm |

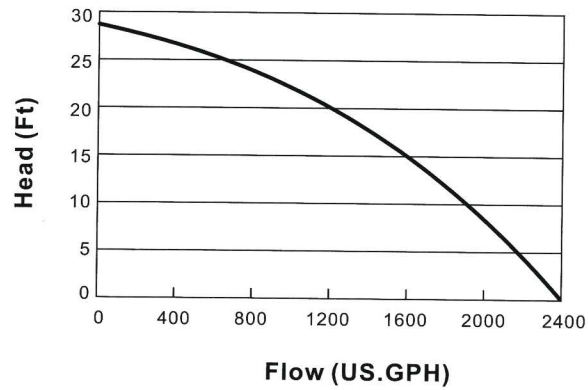

Base plate assembling

Step 1 : Insert the fitting



Step 2 : Assembling the base

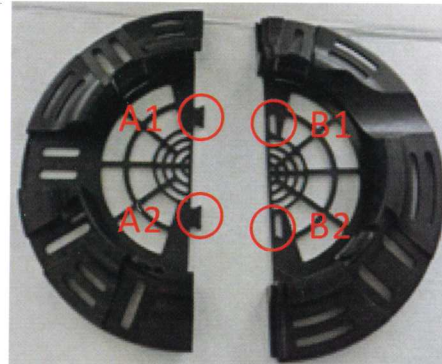

Insert button A into Groove B

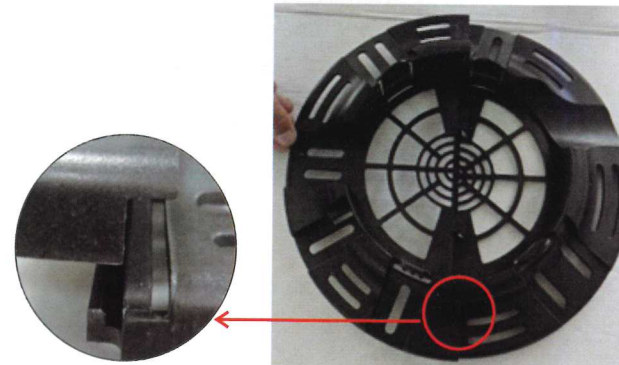

B

Step 3 :Place the filter screen

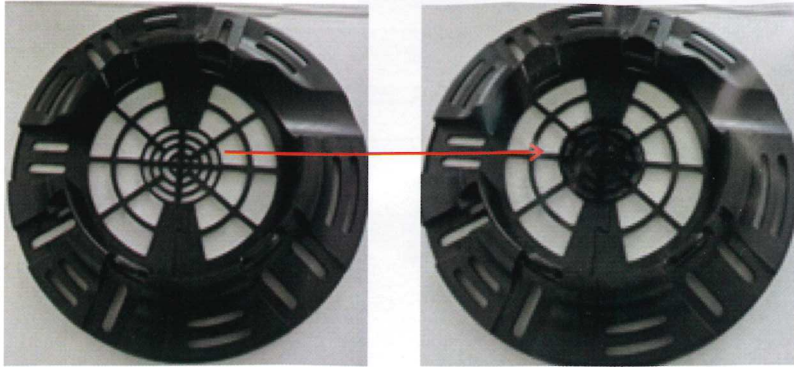

Step 4: place the pump onto the base

