



Super Pump® VS

VARIABLE-SPEED PUMP SERIES



Superior energy savings from the name you know and trust.

Super Pump variable-speed pumps from Hayward® offer **energy savings of up to 80%** over single-speed pumps and pay for themselves faster than larger, more expensive models. Super Pump VS 115V is the most energy-efficient pump in its class, according to EPA ENERGY STAR® third-party testing, and Super Pump VS 230V's all-in-one compatibility makes it easy to integrate with any automation system, including Hayward OmniLogic®. With all of this and more, Super Pump VS pumps are the easiest and most cost-effective upgrades on the market—in fact, purchasing one qualifies you for rebates from your energy service provider (where offered), saving you even more money. Visit Hayward.com/VSPRebates for a complete listing.





The intuitive control interface rotates to four positions on the pump, so it's always easy to read and operate.

4-Position Digital Programmable Control Interface
Includes customizable speed and timer functions and monitors power consumption to maximize energy savings.

Advanced Motor Design
Permanent magnet, totally-enclosed fan cooled (TEFC) design provides unparalleled energy efficiency and reliability.



Exclusive Swing-Away Hand Knobs
Allow easy strainer cover removal without tools.

110 Cubic-Inch Basket
Extra leaf-holding capacity.

See-Through Strainer Cover
Easy to see when the basket requires cleaning.

Self-Priming Capability
Suction lift up to 10' above water level.

Incredibly quiet operation, especially at lower, energy-saving speeds.

Right for your pool. Right for the environment. Right for you.

Perfectly tailored performance.

Super Pump® VS pumps are available in both 230V and 115V models, so every pool owner can enjoy the energy efficiency of a variable-speed pump without the need for costly rewiring. And with Super Pump's right-sized design, you get the savings you want without any energy-sapping extras you don't.

Unrivalled energy efficiency.

As the only pumps of their kind with super-efficient permanent magnet motors, Super Pump VS pumps save more energy, which in turn saves you more money. Super Pump VS 115V is the most energy-efficient pump of its kind, according to EPA ENERGY STAR® third-party testing, and both models provide up to 80% energy savings over single-speed pumps.



Compatible, convenient operation.

A rotatable user interface is yet another way Super Pump VS pumps cater to your needs. The intuitive control pad can be turned in four directions or removed and wall-mounted. Designed with all-in-one compatibility, Super Pump VS pumps are also easy to connect to any automation system, either directly or with relays.

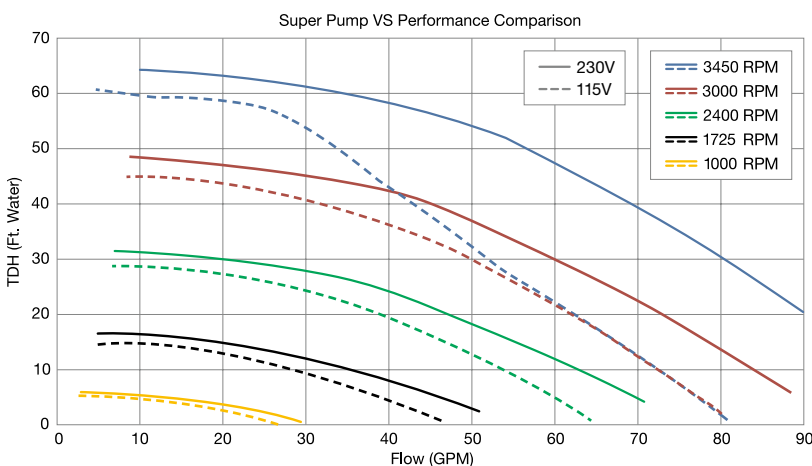

Super Pump VS Features & Benefits

- With right-sized design, they pay for themselves faster than larger, more expensive models.
- All-in-one compatibility works in standalone mode or with any automation system via relay control; 230V model can connect directly to Hayward automation, including OmniLogic®.
- Built with a permanent magnet motor for up to 80% energy savings over single-speed pumps.
- Integrated, programmable, rotatable digital interface with 24-hour clock and up to 8 custom timer functions.
- Optional wall-mount kit available to remotely locate the pump user interface.

Super Pump VS Dimensions (Inches)

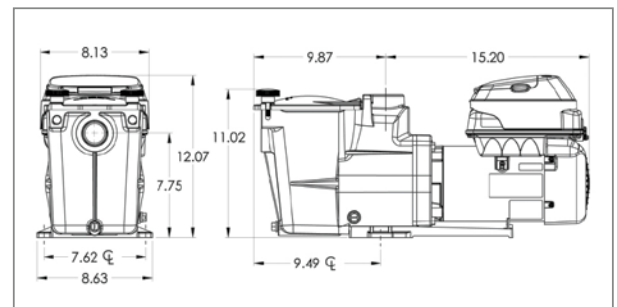

MODEL NUMBER	STAND ALONE	RELAY CONTROL	HAYWARD AUTOMATION	TOTAL HP	VOLTAGE
SP2603VSP	•	•	•	1.65	230V Single Phase
SP26115VSP	•	•		0.85	115V Single Phase

Super Pump VS pumps are listed by:

To take a closer look at Super Pump VS or other Hayward® products, go to hayward.com or call 1-888-HAYWARD.

Hayward, OmniLogic and Super Pump are registered trademarks of Hayward Industries, Inc. © 2016 Hayward Industries, Inc. ENERGY STAR is a registered trademark owned by the U.S. government. All other trademarks not owned by Hayward are the property of their respective owners. Hayward is not affiliated with or endorsed by those third parties.

