



HAYWARD®

Sense and Dispense™

ORP and pH Sensing Kit for OmniLogic

Owner's Manual



Contents

Description.....	1
Installation.....	2
Operation.....	13
Maintenance.....	17
Warranty.....	18

HL-CHEM

Hayward Pool Products
620 Division Street, Elizabeth NJ 07207
www.hayward.com



HAYWARD®

FCC Statement

This device complies with part 15 of the FCC rules. Operation is subject to the following two conditions: (1) This device may not cause harmful interference, and (2) this device must accept any interference received, including interference that may cause undesired operation.

Changes or modifications not expressly approved by Hayward could void the user's authority to operate this equipment.

NOTE: This equipment has been tested and found to comply with the limits for a Class B digital device, pursuant to Part 15 of the FCC Rules. These limits are designed to provide reasonable protection against harmful interference in a residential installation. This equipment generates, uses and can radiate radio frequency energy and, if not installed and used in accordance with the instructions, may cause harmful interference to radio communications. However, there is no guarantee that interference will not occur in a particular installation. If this equipment does cause harmful interference to radio or television reception, which can be determined by turning the equipment off and on, the user is encouraged to try to correct the interference by one or more of the following measures:

- Reorient or relocate the receiving antenna.
- Increase the separation between the equipment and receiver.
- Connect the equipment into an outlet on a circuit different from that to which the receiver is connected.
- Consult the dealer or an experienced radio / TV technician for help.

Industry Canada Statement

This Class B digital apparatus complies with Canadian ICES-003.

Cet appareil numérique de la classe B est conforme à la norme NMB-003 du Canada.

The term "IC" before the certification / registration number only signifies that the Industry Canada technical specifications were met.

Description

The HL-CHEM is an ORP and pH sensing kit that is offered as an accessory for all OmniLogic® pool automation controls. With the HL-CHEM, the OmniLogic can provide a fully integrated chemistry solution for your pool. The HL-CHEM continuously tests the pool's sanitization and pH levels allowing the OmniLogic to automatically generate the correct amount of chlorine and dispense the proper amount of pH reducer. Together, they provide an automated system controlling both sanitization and pH balance.

The HL-CHEM comes with two pigtails (120 VAC and 240 VAC) for connection to a pH reducing device like a peristaltic pump or solenoid valve (not included) that requires a line cord receptacle. For easy integration, Hayward offers the AQL-CHEM2 (120 VAC) and AQL-CHEM2-240 (240 VAC) CO₂ dispense kit that plugs into the pigtail and will reduce the pool's pH level by injecting CO₂ into the pool water.



HAYWARD®

What's Included

The HL-CHEM comes with everything needed to allow the OmniLogic to sense ORP and pH levels. The following is a description of the included components:

Professional Grade ORP probe - Samples water from the pool filtration system and sends signals to the OmniLogic indicating the oxidation-reduction potential (redox) of the pool water. ORP is an actual measurement of sanitizer activity and bacteriological water quality rather than an expression of chemical residual levels. ORP is not fooled by the effects of pH, TDS (total dissolved solids) and other factors giving a more accurate measurement of the effectiveness of chlorine and water quality.

Professional Grade pH probe - Samples water from the pool filtration system and sends signals to the OmniLogic indicating the acidity of the water. When used with a Hayward AQL-CHEM2 or other pH dispensing device, the OmniLogic can keep the pool water's pH level balanced.

Probe Cell - The Probe Cell is used to house the probes and provide a location for water collection and testing. Two hoses are provided to connect the Probe Cell to the supply and return sides of the pool filtration system. The Probe Cell can be mounted directly to the OmniLogic or remote mounted in the vicinity of the control (restricted by the length of the probe wiring).

pH Dispense Pigtails - The pH Dispense pigtails provide a plug-in receptacle for the AQL-CHEM2, AQL-CHEM2-240 or other pH related dispensing device (peristaltic pumps, solenoid valves, etc.) that will be controlled by the OmniLogic.

Various Hardware - The HL-CHEM includes the necessary tubing, tubing connectors and mounting hardware to complete the installation.

Compatibility

The HL-CHEM is compatible with the OmniLogic pool control. An AQL-CL chemistry kit must be used with the OmniLogic if automatic chlorine generation is desired.

Installation

DANGER of Death, Injury or Property Damage if procedure not followed. This accessory connects to the OmniLogic panel beneath the dead front. Dead front removal is required for this installation. Power to the OmniLogic panel **MUST** be shut off before the dead front is removed. This means a complete shutdown of power to the entire OmniLogic panel

Overview

Installing the HL-CHEM requires the following steps:

- Mounting the Probe Cell
- Plumbing the Probe Cell
- Installing ORP and pH probes
- Wiring probes to Probe Cell communication box



HAYWARD®

- Wiring the Probe Cell to the OmniLogic
- Wiring the pH Dispense Pigtail to the OmniLogic
- Configuring the OmniLogic
- Validating Operation
- Establishing Maintenance Schedule

Materials Needed for Installation

- 7/16" drill bit
- ¼" NPT tap
- Two small adjustable wrenches if side mounting to OmniLogic
- 3/16" drill bit if side mounting to OmniLogic
- Deburring tool or file if side mounting
- Mounting hardware if surface mounting (not side mounting)
- Flex tubing cutter
- Water-tight strain relief for dispense pigtail
- Flathead screwdriver and mallet to remove knock-out and install strain relief
- 120 VAC Ground Fault Circuit Breaker (GFCB) for powering 120 VAC dispense pigtail or 240 VAC (GFCB) for powering 240 VAC dispense pigtail
- Extra wire, wire strippers, and wire nuts could be helpful in some installations
- Any items that would be required for wiring and installation per local code

Before carrying out any part of the installation, you **MUST** power down the OmniLogic panel. If the pool filter pump is not powered from the OmniLogic, it **MUST** be powered down separately. This will relieve pressure in the pool filtration system.

Mounting the Probe Cell

The Probe Cell can be mounted directly on the side of the OmniLogic or mounted up to 15' away (limited by length of Probe Cell cable). When mounting remotely, take into account the amount of cable needed to route through the OmniLogic.

The key to successful Probe Cell installation is in the plumbing. A pressure differential is required to allow clean, untreated water to pass through the cell and across the probes. Consider this when looking for an ideal mounting location.

Side Mounting: Side mounting the HL-CHEM will require drilling 3 mounting holes through the "dimples" found on the side of the OmniLogic enclosure. Refer to the diagram and steps below.

OmniLogic power must be shut off before the enclosure can be drilled.

- 1) Remove door and front panel.
- 2) Use a 3/16" dia. drill bit and drill through the three "dimples" on the side of the enclosure. Take care that any wires behind the enclosure wall are clear and will not be damaged by the drill bit.
- 3) After the holes are drilled, grind or file down any burrs and brush away any metal chips.
- 4) Route Probe Cell cable through access hole at bottom of Probe Cell mounting bracket.
- 5) Use the included stainless steel hardware to fasten the HL-CHEM to the OmniLogic as shown on the top of the following page.



HAYWARD®

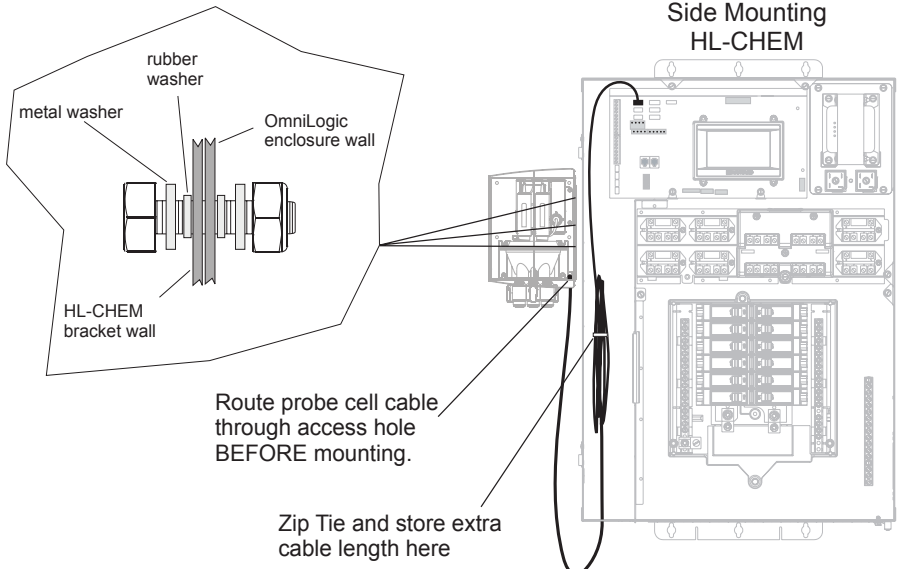

Surface mounting: The Probe Cell can be mounted up to 15' away from the OmniLogic (limited by length and routing of cable). Use the four mounting holes on the back of the bracket when surfacing mounting. Common wood screws can be used for most applications.

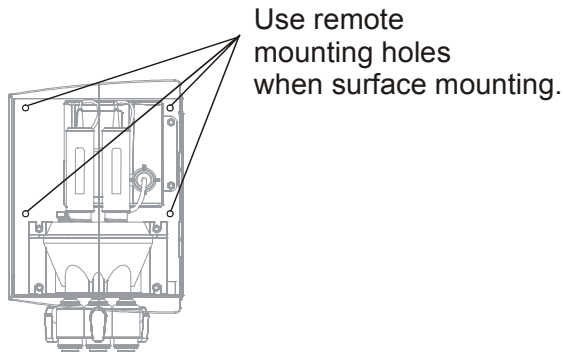

Plumbing the Probe Cell to the pool plumbing

The Probe Cell requires connection to the pool plumbing using the supplied flex tubing. Two ports on the Probe Cell, influent and effluent, are connected to the supply and return sides of the pool plumbing. Refer to diagram on the following page as well as the instructions.



HAYWARD®

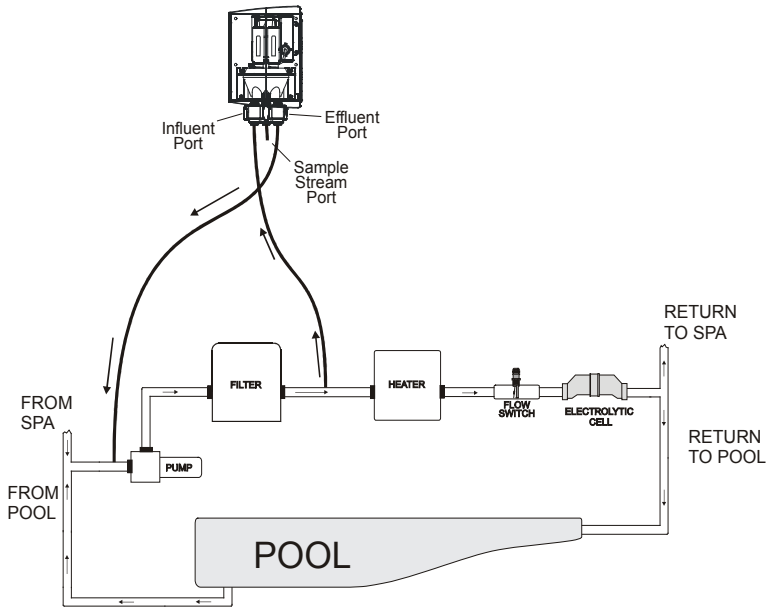

Drill and tap a $\frac{1}{4}$ " NPT hole using a $\frac{7}{16}$ " drill bit on the return side of the pool plumbing at a location just downstream of the filter, but upstream from the AQL-CL Electrolytic Cell. Use caution not to tap tapered threads too deeply. Using teflon plumber's tape, install a tubing connector into the hole. Run flex tubing from the tubing connector to the influent Probe Cell port. Push the flex tubing all the way into the pressure fitting to seat.

Drill and tap another $\frac{1}{4}$ " NPT hole on the supply side of the pool plumbing. Use caution not to tap tapered threads too deeply. Using teflon plumber's tape, install the remaining tubing connector and run flex tubing to the effluent Probe Cell port. Push the flex tubing all the way into the pressure fitting to seat.

Cut a 3" length of flex tubing and insert it into the sample stream port. This port can be used to draw water samples if needed.

If flex tubing needs to be replaced, use only $\frac{3}{8}$ " UV-resistant cross-linked polyethylene tubing (PEX).

Installing ORP and pH probes to the Probe Cell

The ORP and pH probes are shipped "wet" in plastic storage caps. It's very important that the probes remain wet at all times. If the probes are allowed to dry out, they will fail and the HL-CHEM will be ineffective. After installation, the Probe Cell will ensure that the probes are constantly exposed to pool water. During periods when the filter pump is off (even extended periods), there should be sufficient moisture remaining in the Probe Cell to ensure that the probes are protected.

Remove the ORP and pH probes from their plastic storage caps and save the caps for future use.

To ensure that the probes continue to remain wet, fill the Probe Cell with pool water before installing the probes. Apply a length of plumber's tape to the probe threads. Hand-tighten the probes only. At startup, check for leaks. If probe leaks, do not tighten more—instead remove and re-apply new Teflon tape.

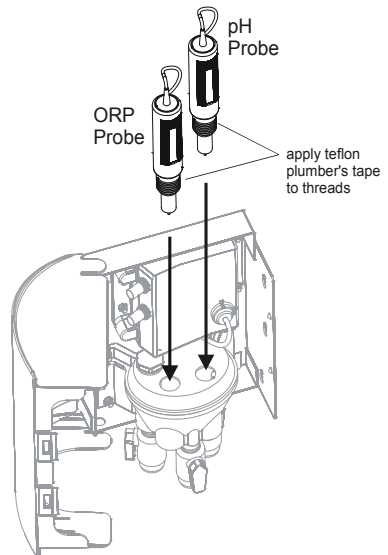

Wiring the probes to the Probe Cell

Both probes must be wired to the communication box within the Probe Cell. The probe cables use typical BNC connectors that attach to the designated connectors on the communication box. Refer to the label on the communication box for the appropriate connections. Push the connectors in and turn clockwise until locked. After connecting, route the wires in a manner where they will not interfere with the door of the Probe Cell. Save BNC connector protective covers for future use.

Wiring the Probe Cell to the OmniLogic

With power off to the OmniLogic, remove the dead front to expose the main board. Route the Probe Cell cable through an available knockout, along the low voltage channel and make the proper connection to the low speed RS-485 bus (4 pin connector) as shown below. When side mounting the Probe Cell, route the cable through the access hole at the bottom of the mounting bracket **BEFORE** screwing the bracket in place.

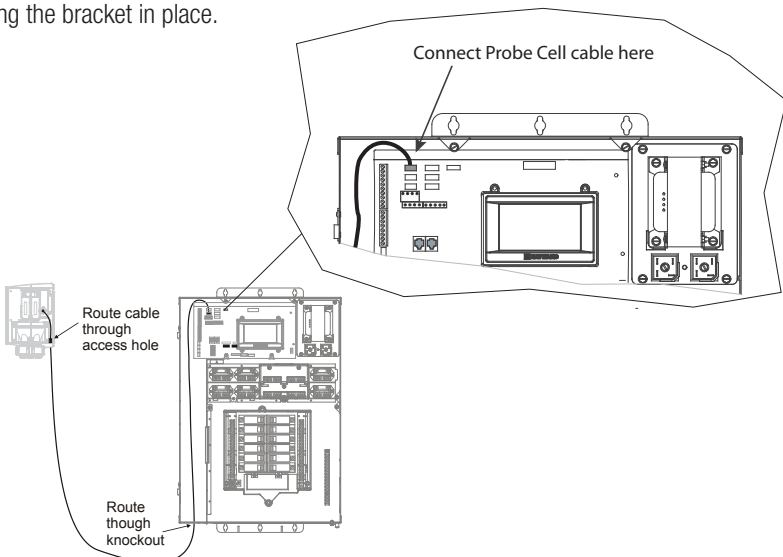



Wiring the Pigtail or pH Dispensing Device

Two pigtails (120 VAC and 240 VAC) are included with the HL-CHEM sensing kit to be used with pH dispensing devices (peristaltic pumps, solenoid valves, etc.) that require a plug-in receptacle, including the Hayward AQL-CHEM2 and AQL-CHEM2-240. If your pH dispensing device will be direct wired (hard wired), the pigtail is not necessary.

WARNING: Follow local codes for pigtail installation. Installation may require retrofitting a weather-tight outlet and plug to the pigtail and dispense hardware (such as Cooper WaterTight or similar connectors) or weather proof junction box.

NOTE: The OmniLogic can use either a 120 VAC or 240 VAC pH dispensing device. Wire the pigtail or device directly to any of the OmniLogic relays. Provide the proper input voltage to the line side of the relay. For 120 VAC, refer to the diagram below. For 240 VAC, refer to the diagram on page 8.

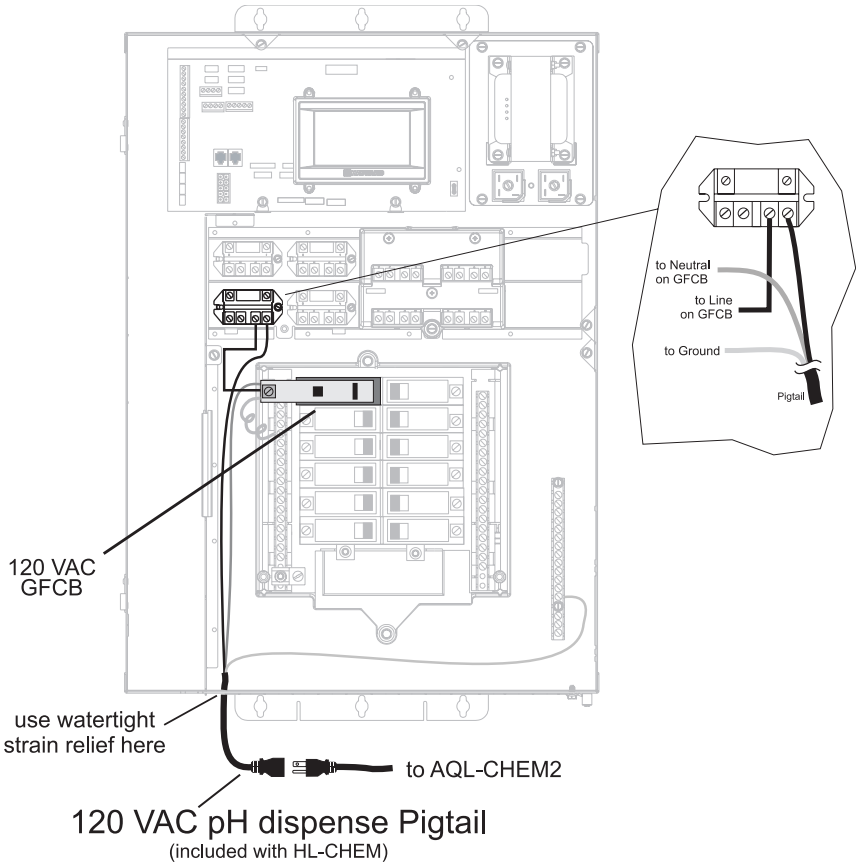



HAYWARD®

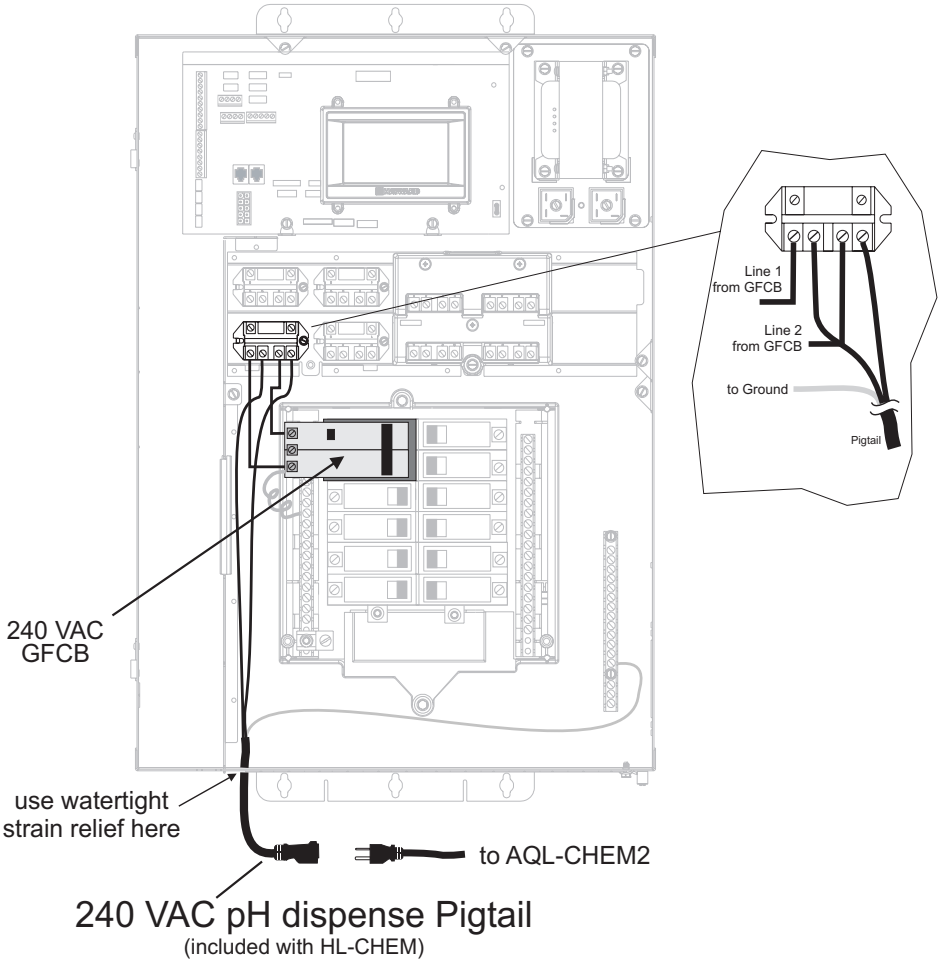

Configuring the OmniLogic

After the HL-CHEM is mounted, plumbed and wired, the OmniLogic must be configured to use the HL-CHEM.

Replace the dead front and restore power to the OmniLogic. At the HOME screen, go to CONFIGURATION in the BACKYARD SCREENS. Enter the CONFIGURATION WIZARD and advance through the menus until you see the screen below.

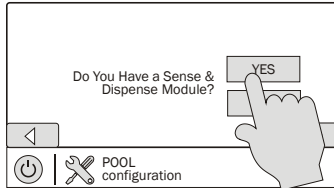

After selecting "Yes", the HL-CHEM will be automatically discovered and you'll be prompted to select a unique address.

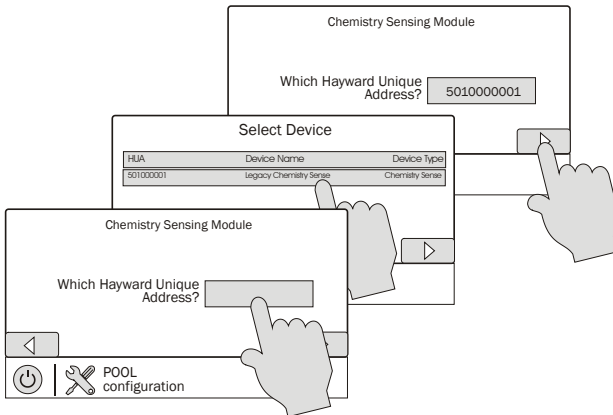

Pressing the box will bring you to a table which shows a list of connected devices. Selecting the HL-CHEM from this table will automatically configure the OmniLogic to use the proper address.

The HL-CHEM is now ready to be configured. You'll be presented with a series of screens that will require you to input desired operating parameters and settings. Refer to the related information on the following pages as you progress through the screens.

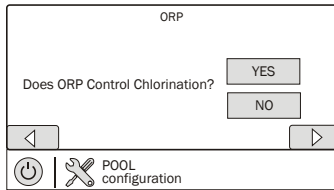

ORP Control

A Hayward AQL-CL Chlorination Kit is needed if chlorine generation is desired.

If "Yes" is selected (AQL-CL Chlorination Kit must be used): You'll automatically be asked to configure ORP settings as shown below. The OmniLogic refers to the ORP level in the pool and automatically adjusts chlorine output to maintain the desired level.

If "No" is selected, and a AQL-CL Chlorination Kit is used: After answering "No", you'll be asked if a Salt Water Chlorine Generator will be used. If you answer "Yes" to this, you'll be prompted to enter a run time %. The OmniLogic will generate chlorine for this % of time during the filter cycle. Chlorine output is based on this manual setting only. ORP level is not used to control the chlorinator output.

If "No" is selected, and a AQL-CL Chlorination Kit is NOT used: After answering "No", you'll be asked if a Salt Water Chlorine Generator will be used. When you answer "No", you'll advance directly to pH configuration.

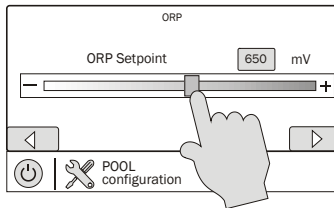

ORP Setpoint

Refer to "Controlling ORP with the OmniLogic" on page 15 for tips on determining the ORP setpoint (650mV default). The HL-CHEM will measure the pool's ORP and generate more or less chlorine to maintain the setpoint setting. Note that the OmniLogic will attempt to maintain this level but typically the pool's ORP level will vary above this value during normal operation. The adjustable range is from 400mV to 900mV in 5mV increments.

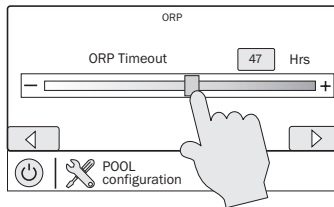

ORP Timeout

To protect the pool, the OmniLogic control will automatically shut down ORP control and display an alarm if the HL-CHEM runs continuously for more than the selected timeout value. This prevents a situation where the OmniLogic is constantly feeding chlorine because of a probe error or external problem with the pool. It allows the pool owner to evaluate the pool chemistry before continuing with ORP control. Select the desired timeout value.

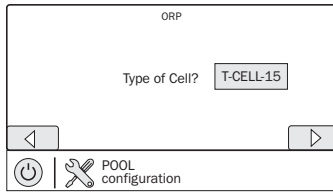

Select Cell

The OmniLogic can use the following Hayward TurboCells:

- T-CELL-15 - select when using T-CELL-15 (inc. with AQL-CL), GLX-CELL-15-W
- T-CELL-9 - select when using T-CELL-9, GLX-CELL-9-W
- T-CELL-3 - select when using T-CELL-3, GLX-CELL-3-W
- T-CELL-5 - select when using GLX-CELL-5, GLX-CELL-5-W

NOTE: Use of a non-genuine Hayward replacement salt chlorination cell on any Hayward automation or chlorination product will void the warranty for that product and could potentially damage the unit.

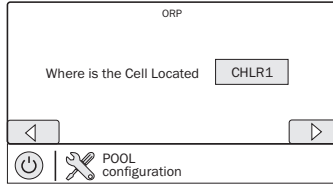

TurboCell Location

Like the HL-CHEM, the TurboCell will automatically be sensed and you will be prompted to select the proper location. Follow the same procedure as shown on page 9.

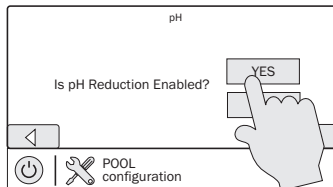

pH Control

If automatic pH reduction is desired, a dispensing device must be connected to one of the relays in the OmniLogic. If so, select "Yes" and configure pH reduction with the following screens.

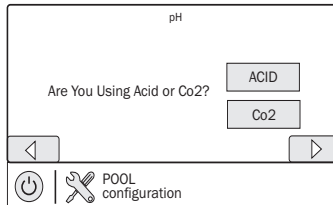

Acid or CO₂

Select the type of pH reduction that will be used.

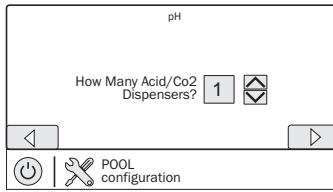

Number of Dispensers

Select the number of dispensers that are wired to the OmniLogic.

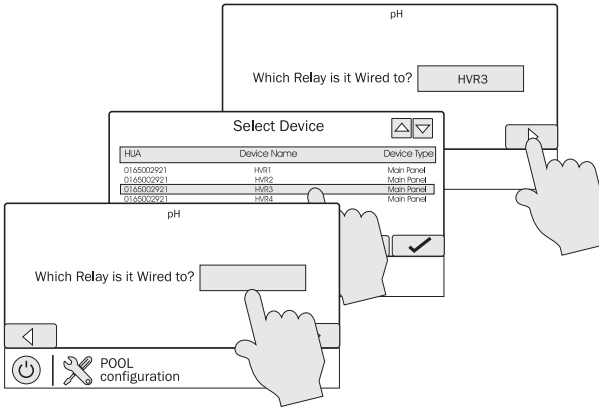

Relay Device Name

Configure the OmniLogic to use the acid or CO₂ dispenser by selecting the relay that is wired to the dispenser.

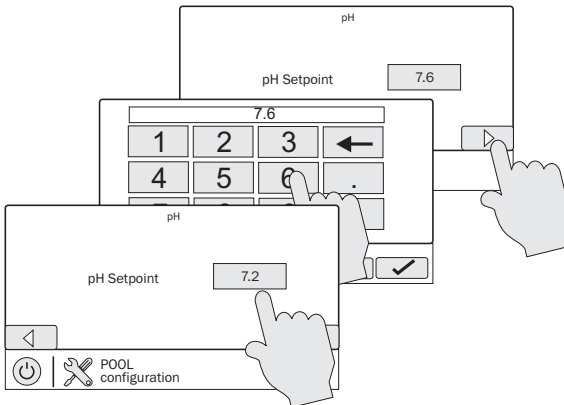

pH Setpoint

Enter the desired pH level. The OmniLogic will dispense CO₂ or acid when necessary to maintain this level. The adjustable range is from 7 to 8 in 0.1 increments.



HAYWARD®

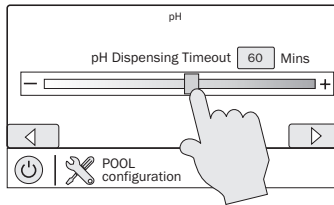

pH Timeout

To protect the pool, the OmniLogic control will automatically shut down pH control and display an alarm if the HL-CHEM runs continuously for more than the selected timeout value. This prevents a situation where the OmniLogic is constantly feeding acid or CO₂ because of a probe error or external problem with the pool. It allows the pool owner to evaluate the pool chemistry before continuing with pH control. The selectable range is 1-120 minutes.

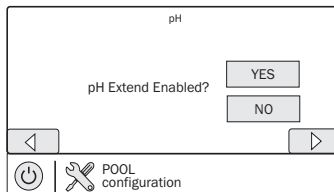

pH Extend

When pH Extend is enabled, the OmniLogic control will keep the pool filter pump on regardless of its timer settings until the pH level is within its programmed parameters. The pump will continue to run and acid or CO₂ will continue to dispense until the programmed levels are reached. When the pH level reaches the setpoint, the pump will be allowed to go back to automatic control.

Operation

Before operating the HL-CHEM, test and adjust the pool water chemistry to the recommended levels shown in the OmniLogic Owner's Manuals. This is an important step and is crucial to the successful operation of the HL-CHEM. If using salt chlorination, adjust salt to recommended levels.

Alarms

After exiting the CONFIGURATION WIZARD, alarms for both ORP and pH will be enabled. To view alarms, click on the ALARM icon found in the BACKYARD SCREENS. Refer to the OmniLogic manual for more information about alarms.

ORP Alarm

The OmniLogic will automatically set a high and low alarm for the ORP level. The high alarm point is 850mV and the low alarm point is 350mV. If the ORP level meets or exceeds these points, an alarm message will display locally and on all remote controls. Also, if the ORP level is too high, chlorine generation will shut down.



pH Alarm

The OmniLogic will automatically set a high and low alarm for the pH level. The high alarm point is 8.1 and the low alarm point is 6.9.

Settings

Although initial settings were entered during configuration, changes may be desired as pool conditions change. To quickly display and change settings, select the desired Body of Water at the HOME SCREEN then go to the SETTINGS SCREEN. Select the following:

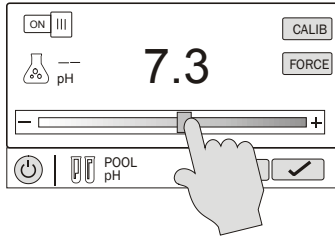

pH Setting Adjust setpoint from 7.0 to 8.0.

On/Off Enable and disable pH dispensing.

Force pH reducer is added for 15 minutes regardless of pH level and then automatically goes to Auto Sensing mode. This mode is helpful when setting up and testing the AQL-CHEM2(-240) or other automatic dispenser.

Calib pH Calibration should take place at initial setup and periodically when the pH read-out doesn't match tested values.

To calibrate the pH probe, test the pH of the pool water with a dependable quality test kit after the pool pump has been running for a period of time. Hayward suggests that you take more than one test and average the results before using the value to calibrate. Compare this result to the current pH reading and enter the offset amount. If the tested value is lower than the current reading, the offset will be negative. If greater, the offset will be positive. Refer to the example below.

Current pH reading: 7.5.
Average of tested readings: 7.3.
Offset: $7.3 - 7.5 = -.2$

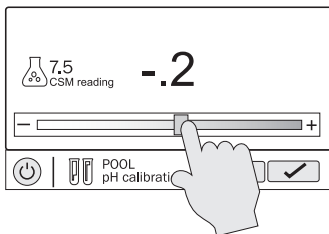



HAYWARD®



chlorinator

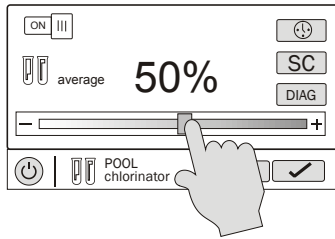

ORP Setting If ORP controls chlorination (page 10), adjust setpoint from 400mV to 900mV. If ORP does not control chlorination, adjust from 0% to 100%.

On/Off Enable and disable ORP sensing and chlorine generation.

Schedule Enable and disable chlorine generation based on time. You can set a unique schedule for the chlorinator that will override filter pump settings. See the OmniLogic manual for details on how to create schedules.

SC Superchlorinate allows you to select a continuous run time for maximum chlorination. Select a run time between 0-96 hours. The OmniLogic will override pump schedules and generate chlorine continuously for this amount of time.

Diag Displays electrical diagnostics for the Turbo Cell.

Controlling ORP with the OmniLogic

Follow these steps to adjust the desired ORP level:

1. **IMPORTANT:** Balance the pool water to the ideal levels shown in the OmniLogic manuals, including pH, total alkalinity, cyanuric acid, hardness and salt level.
2. Adjust the chlorine to the ideal level as well; e.g. 1-3 ppm free chlorine. This chlorine level is what we want to maintain.
3. After allowing the system to run for 30-60 minutes, observe what the Sense and Dispense system reports as the pool water ORP level.
4. Set the ORP setpoint setting to this reported ORP level.
5. Monitor the free chlorine and ORP every day for 1 week. If adjustments to the ORP setpoint are needed, make adjustments in increments of 10 or 20 mV units—**LARGE ADJUSTMENTS OF THE ORP SETPOINT SHOULD NOT BE NECESSARY IF YOU STARTED WITH A BALANCED**



HAYWARD®

POOL THAT HAD THE PROPER AMOUNT OF FREE CHLORINE.

6. If the system is not stabilizing (or does not seem to be stabilizing) there are 3 things you can do:
 - a. Clean the probe
 - b. Rebalance the pool—including the free chlorine level
 - c. Check for combined chlorine—if high (>0.5ppm), shock treat with chlorine or non-chlorine shock

Controlling pH with the OmniLogic

Plaster pools and pools serviced by salt-chlorine generators typically cause a slow pH rise which must be managed. With the Sense and Dispense technology, CO₂ or acid is dispensed into the filter system's return water as needed until the pH probe reports proper pH level.

The Hayward AQL-CHEM2(-240) are CO₂ dispensing systems that eliminate the need to handle acid and are economical and efficient methods for effective pH control. When the CO₂ gas is injected into water, it dissolves and becomes carbonic acid, a weak acid that is very effective at lowering pH but becomes self-limiting if over-fed.

CAUTION: IF YOU CHOOSE AN ACID FEEDER FOR pH CONTROL, additional safety precautions are required to ensure that an equipment malfunction is detected. Great care must be taken when installing, maintaining and operating acid pump feed systems. Acid is dangerous to handle, and will harm people and equipment if not properly contained, transported, poured, stored, and dispensed.

CAUTION: Equipment failure can potentially cause too much acid to be dispensed into the water, causing an equipment and health hazard which would not be detectable without the use of independent pH measurement.

- Always use a 4:1 dilution in the acid feed system.
- **CAUTION: To prevent a violent reaction, ALWAYS ADD ACID TO WATER, never add water to acid to dilute it. Some use the rhyme "Remember, do as you oughta- add acid to water"**
- Strictly follow the acid vendor's safety and handling protocols including hand, body and eye protection when transferring or handling acid.
- Choose a 5 gallon per day acid feed pump to keep flow rate low.
- Limit the available acid reservoir to 1 gallon per 15,000 gallons of water. This limits the available acid in the event that equipment malfunctions and empties the tank into the pool or spa.
- Only a properly installed and maintained system will control the pH and sanitizer levels of the water.
- **WARNING: If acid is not diluted properly or the feed pump is oversized, it will overshoot the pH correction.**
- At least monthly, use an independent pH and chlorine test kit to verify that pH and chlorine are at a safe level. If the probes are broken, depleted, dirty, fouled with oils, lotions, or other contaminants, they can report inaccurate result to the system causing incorrect water chemistry, which at worst, could harm people or equipment.
- Check the OmniLogic's display each day before entering the water. If there is an alarm, follow the troubleshooting guide to understand and rectify the condition. If the display is blank, or reporting a communications error, troubleshoot the equipment and rectify the failure before entering the water.



HAYWARD®

- Follow the installation checklist to verify proper operation upon installation and at the beginning of each pool season.

Maintenance

Water Chemistry

Always test water chemistry with a quality manual test kit. The HL-CHEM provides instrument grade accuracy which exceeds that of most liquid-standard water testing kits. Therefore, it may be preferable to calibrate pH using commercially available reference solutions. Calibrate pH periodically using the method described earlier in this manual. It's important to note that changes in pH, cyanuric acid concentration, total dissolved solids, and use of additional or alternative sanitizers will all affect the primary sanitizer residual level relative to ORP. Maintain total alkalinity on a regular basis to ensure pH stability. To maintain a consistent sanitizer residual in parts per million (ppm), periodically adjust the ORP level.

Probe Maintenance

The probes must be clean and free from oil, chemical deposits and contamination to function properly. After saturation in pool or spa water, the probes may need to be cleaned on a weekly or monthly basis depending on bather load and other pool specific characteristics. Slow response, increased need to calibrate pH, and inconsistent readings are indications that the probes are in need of cleaning.

To clean the probes without running the Wizard, turn off input power to the OmniLogic. Disconnect the probe connectors from the communication box, unscrew the probe and carefully remove them from the Probe Cell. Clean the reference junction (the white ring at the bottom of the probe body) with a soft toothbrush and regular tooth paste. A household liquid dishwashing detergent may also be used to remove any oil. Rinse with fresh water, replace teflon tape on threads and reinstall probes. If properly cleaned probes continue to provide unstable readings or require excessive calibration, the probes should be replaced.

Probe Storage

Exposure to atmospheric conditions will cause the probe tips to dry out. Store the probes with the included plastic probe storage caps if removed from the Probe Cell for more than one hour. If the storage caps have been misplaced, store the probes individually in small glass or plastic containers with clean water covering the probe tips. Store probes in a location that will not be subjected to freezing temperatures.

Winterizing

The HL-CHEM probes must be protected from freezing conditions. If the pool is winterized, plan to remove and store the probes (as described above) as part of the normal pool winterizing process. The Probe Cell and related plumbing must be drained as well. BNC connectors should be capped with the original protective covers. A winterizing kit with probe caps, BNC covers, and other necessary winterizing accessories is available to replace any missing items. Contact your local Hayward dealer for more information.



HAYWARD®

LIMITED WARRANTY (effective 03/01/12) Hayward warrants its Pro Logic, OnCommand and E-Command pool automation products as well as its Aqua Rite, Aqua Rite Pro, Aqua Plus and SwimPure chlorination products to be free of defects in materials and workmanship, under normal use and service, for a period of three (3) years. Hayward also warrants its Aqua Trol chlorination products to be free of defects in materials and workmanship, under normal use and service for a period of one (1) year. These warranties are applicable from the initial date of purchase on private residential swimming pools in the US and Canada. Installations of product for use on commercial pools in the US and Canada is covered for a period of one (1) year for defects in materials and workmanship. Hayward warrants all accessories and replacement parts for the above-identified pool automation and chlorination products for a period of one (1) year. Accessories also include remotes, actuators, base stations, temperature sensors, flow switches and chemistry probes. Each of these warranties is not transferable and applies only to the original owner.

Hayward shall not be responsible for cartage, removal, repair or installation labor or any other such costs incurred in obtaining warranty replacements or repair.

Proof of purchase is required for warranty service. If written proof of purchase is not provided, the manufacturing date code will be the sole determinant of the date of installation of the product. To obtain warranty service or repair, please contact the place of purchase or the nearest Hayward authorized warranty service center. For more information on authorized service centers please contact the Hayward Technical Service Support Center (61 Whitecap Road, North Kingstown RI, 02852) or visit the Hayward web site at www.hayward.com.

WARRANTY EXCLUSIONS:

1. Material supplied or workmanship performed by others in process of installation.
2. Damage resulting from improper installation including installation on pools larger than the product rating.
3. Problems resulting from failure to install, operate or maintain the product(s) in accordance with the recommendations contained in the owners manual(s).
4. Problems resulting from failure to maintain pool water chemistry in accordance with the recommendations in the owners manual(s).
5. Problems resulting from tampering, accident, abuse, negligence, unauthorized repairs or alternations, fire, flood, lightning, freezing, external water, degradation of natural stone used in or immediately adjacent to a pool or spa, war or acts of God.
6. Use of a non-genuine Hayward replacement salt chlorination cell on any Hayward automation or chlorination product will void the warranty for that product.

The express limited warranty above constitutes the entire warranty of Hayward Pool Products with respect to its products and is in lieu of all other warranties expressed or implied, including warranties of merchantability or fitness for a particular purpose. In no event shall Hayward Pool products be responsible for any consequential, special or incidental damages of any nature. Some states do not allow a limitation on how long an implied warranty lasts, or the exclusion of incidental or consequential damages, so the above limitation may not apply to you. This warranty gives you specific legal rights, and you may also have other rights, which vary from state to state.

For further information or consumer
technical support, visit our website at
www.hayward.com



Hayward is a registered trademark and OmniLogic and Sense and Dispense are trademarks of Hayward Industries, Inc. © 2013 Hayward Industries, Inc.

All other trademarks not owned by Hayward are the property of their respective owners. Hayward is not in any way affiliated with or endorsed by those third parties.

USE ONLY HAYWARD GENUINE REPLACEMENT PARTS