

# INSTALLATION & OPERATING INSTRUCTIONS

## SWIMMING POOL & SPA HEATER D-2

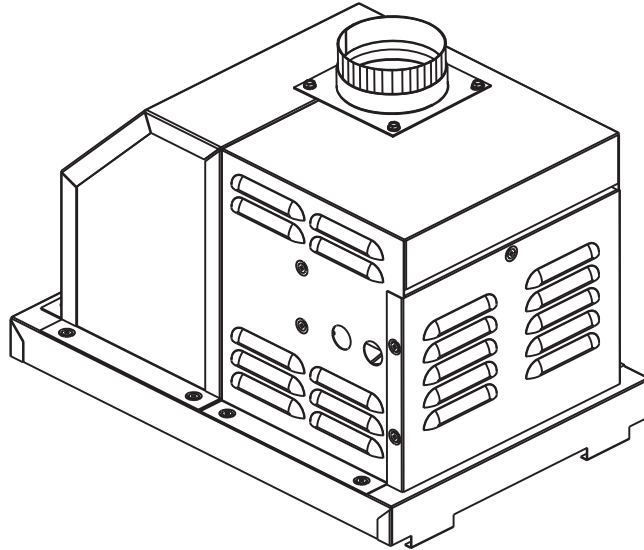

**D-2 POWER VENT**  
**206A, 207A, 266A, 267A, 268**  
**336A, 337A, 406A, 407A, 408**  
**(ELECTRONIC IGNITION MODELS ONLY)**

**WARNING:** If these instructions are not followed exactly, a fire or explosion may result causing property damage, personal injury or death.

Do not store or use gasoline or other flammable vapors and liquids in the vicinity of this or any other appliance.

**WHAT TO DO IF YOU SMELL GAS:**

- Do not try to light any appliance.
- Do not touch any electrical switch; do not use any phone in your building.
- Immediately call your gas supplier from a neighbor's phone. Follow the gas supplier's instructions.
- If you cannot reach your gas supplier, call the fire department.

Installation and service must be performed by a qualified installer, service agency or the gas supplier.

This manual should be maintained in legible condition and kept adjacent to the heater or in a safe place for future reference.

**Rev. 4** reflects the following:

**Changes to:** Illustrations on pages 1, 4, and 22, Installation Step 14 on page 7, Venting instructions on page 9, Venting Clearances on page 11, Wiring Diagrams on pages 19 and 20, Parts List on page 23

**Additions:** 268 and 408 Raypak Professional models on pages 1, 3, 4, 6 and 15, Fig. 15 and Fig. 16 on page 7, Wiring Diagram on page 21

## RECEIVING EQUIPMENT

On receipt of your equipment, it is suggested that you visually check for external damage to the carton. If the carton is damaged, it is suggested that a note be made on the Bill of Lading when signing for equipment. Remove the complete assembly from the carton. If it is damaged, report the damage to the carrier immediately. Be sure that you receive the number of packages indicated on the Bill of Lading. Claims for shortages and damages must be filed with the carrier by consignee.

Purchased parts are subject to replacement only under the manufacturer's warranty. Debts for defective replacement parts will not be accepted and defective parts will be replaced in kind only per our standard warranties.

When ordering parts, you must specify the kit number. When ordering under warranty conditions, you must also specify the date of installation.

The manufacturer recommends that this manual be reviewed thoroughly before installing the D-2 Power Vent. If there are any questions which this manual does not answer, please contact your local Representative.

THIS MANUAL SHOULD BE MAINTAINED IN LEGIBLE CONDITION AND KEPT ADJACENT TO THE UNIT.

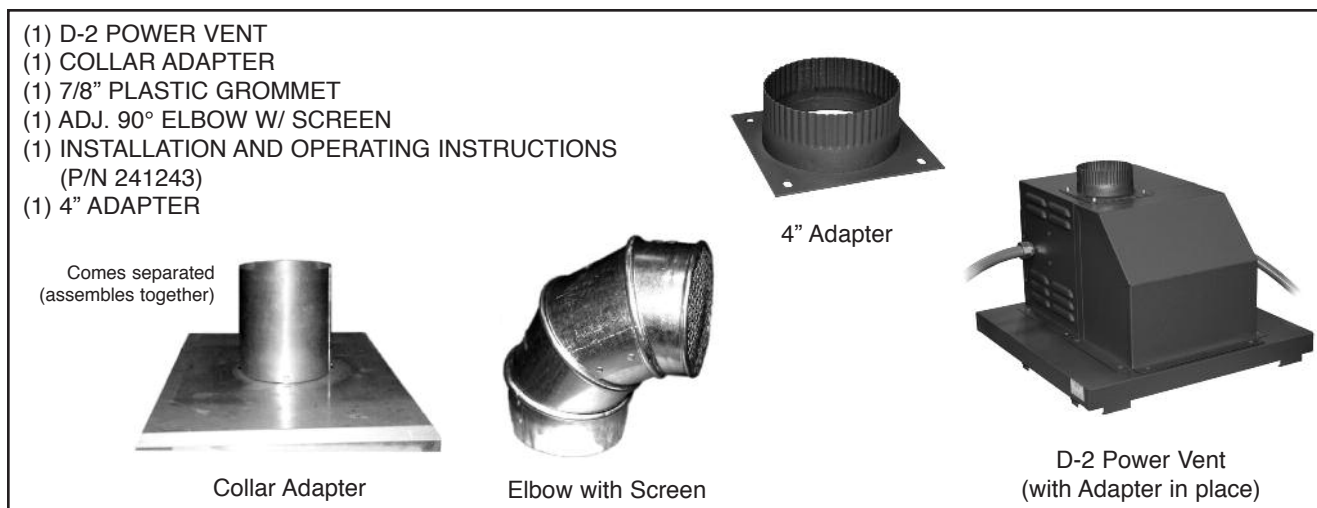

## GENERAL SPECIFICATIONS

The D-2 Power Vent is tested and certified to the latest edition of the American National Standard ANSI Z21.56 standard for pool heaters.

The D-2 Power Vent is a fan-assisted combustion system designed for application to heater models 206 thru 408. When installed as directed, the unit is capable of operating in applications such as through-the-wall venting and reduced horizontal and vertical vent pipe sizes in new and existing installations.

The D-2 Power Vent includes a blower with a 120/240 volt 60Hz 1.95/1.0A 3200 RPM motor and a plenum, complete with a draft proving switch and a motor relay.

HEATER MODELS	FACTORY-WIRED	D-2 POWER VENT PART NO.
206/207 - 266/267/268	240 VAC	009832
336/337 - 406/407/408	240 VAC	009833
206/207 - 266/267/268	120 VAC	010744
336/337 - 406/407/408	120 VAC	010745

## DIMENSIONS

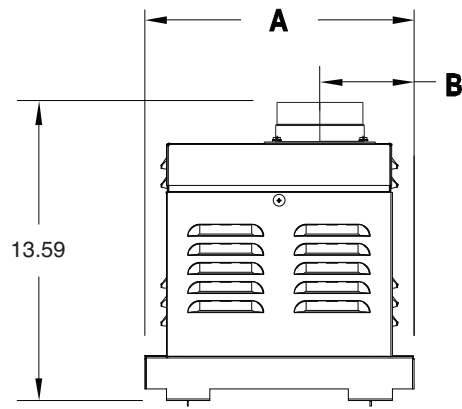
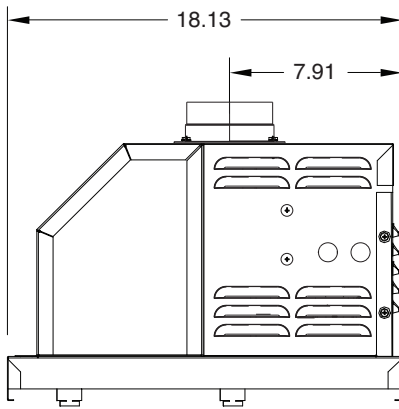

DIMENSIONAL DATA		
Model	A	B
206/207 266/267/268	12.31	4.31
336/337 406/407/408	18.31	7.31

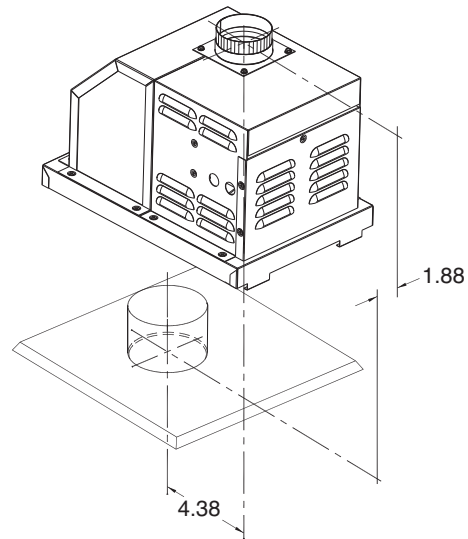

## INSTALLATION REQUIREMENTS

Failure to install, maintain and/or operate the Power Vent in accordance with manufacturer's instructions may result in conditions which can produce bodily injury and property damage.

The equipment must be installed by a qualified installer in accordance with all local codes, or, in the absence of local codes, with the latest edition of the National Fuel Gas Code, ANSI Z223.1/NFPA 54 and the National Electrical Code, ANSI/NFPA 70. In Canada, installations must conform to CAN/CSA B149.1 and to the latest Canadian Electrical Code Part 1.

Disconnect power supply when making wiring connections or when working around the fan blade and motor. Failure to do so may result in severe personal injury and equipment damage.

Make certain the power source is adequate for the fan motor requirements. Do not add the Power Vent to a circuit where the total load is unknown.

## INSTALLATION

1. Start off by disconnecting main power to the heater.
2. Remove the front door from the heater. See Fig. 1.
3. If this is a retro-fit application, remove existing "Pagoda Top" and discard. See Fig. 2. If equipped with a draft hood, refer to draft hood installation manual for removal process.
4. Remove the (6) Phillips screws that hold the jacket top to the heater. See Fig. 3.
5. Lift the rear end of the jacket top while inserting the collar adapter. See Fig. 4 & 5.  
Note: Brackets are positioned underneath the collar adapter to capture the smaller model, See Fig. 6. Also note the orientation of the adapter on the heater as shown in Fig. 7.

Remove door by unfastening knurled screw shown.

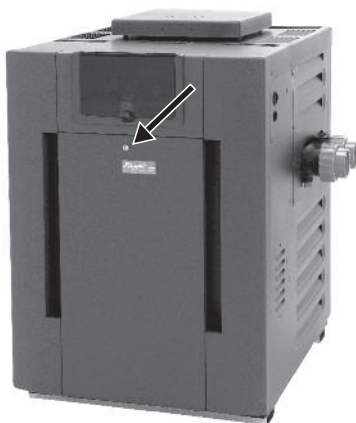

Fig. 1

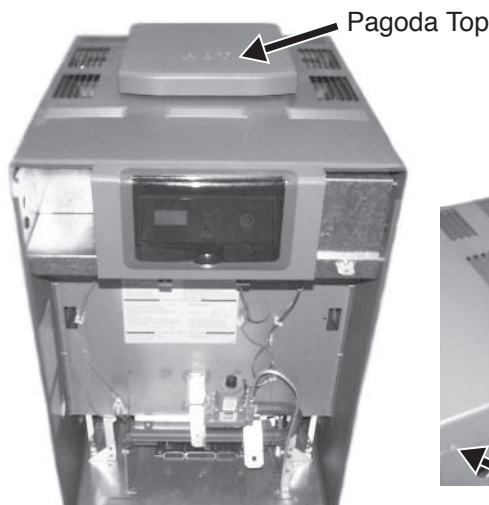

Fig. 2

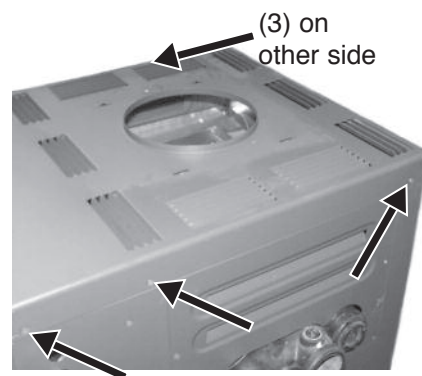

Fig. 3



Fig. 4

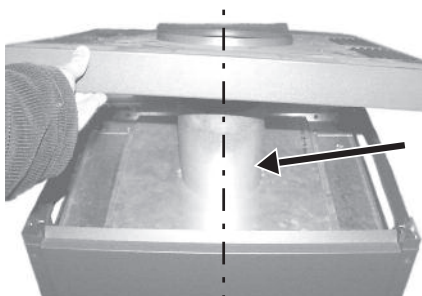

Fig. 5

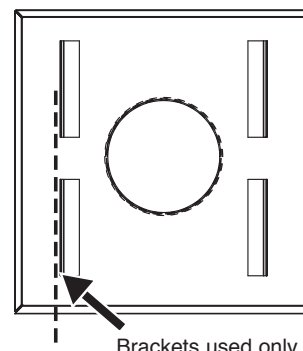

Fig. 6

Brackets used only on 206/207/336/337 models to hold collar adapter in place

## INSTALLATION (Continued)

6. Lower the jacket top back onto the heater and reinstall the (6) Phillips screws. See Fig. 3.
7. If installing on a model 266, 267, 268, 406, 407 or 408 heater, skip step 8.
8. Turn the Power Vent upside down. Using a 5/16" nut driver, relocate the mounting brackets as shown in Fig. 8.
9. Place the Power Vent on top of the heater. See Fig. 9.
10. Move the Power Vent, so that the collar adapter slips into the Power Vent. See Fig. 10.
11. Push in all four bracket tabs, so the Power Vent locks into position. See Fig. 11.
12. Using a 5/16" nut driver, remove the transformer cover located on the right side of the heater. See Fig. 12.

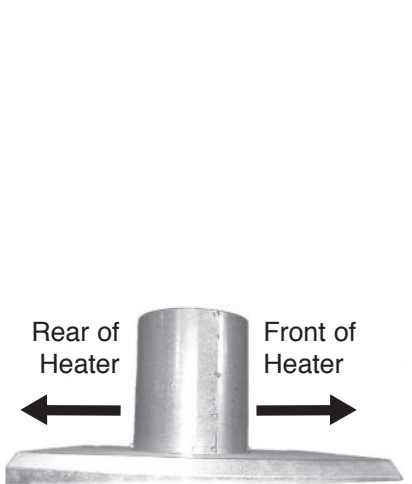

Fig. 7

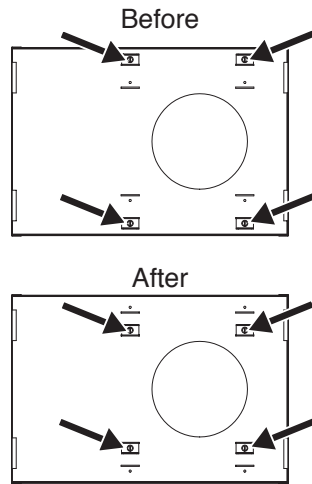

Fig. 8



Fig. 9



Fig. 10



Tab

Tab

Fig. 11

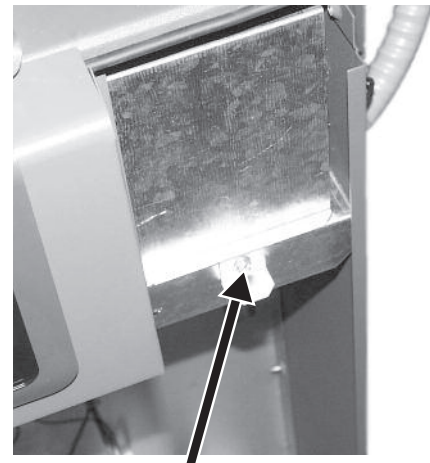

Access  
Screw

Fig. 12

## INSTALLATION (Continued)

13. Install the right side outdoor conduit through the top 7/8" hole located on the right side of the heater. See Fig. 13. Note: You must first remove the 7/8" plug on the heater to install the hard conduit.
14. Wire the heater power lines along with the D-2 Power Vent power lines to the supply power per Fig. 15 for 010744 or 010745, and per Fig. 16 for 009832 or 009833. If the D-2 does not match the power supplied, re-wire the blower for the correct voltage.
15. Reinstall the transformer cover. See Fig. 12.
16. Install the left side outdoor conduit through the top 7/8" hole located on the left side of the heater. See Fig. 14. Note: You must first remove the 7/8" plug on the heater to install the conduit.

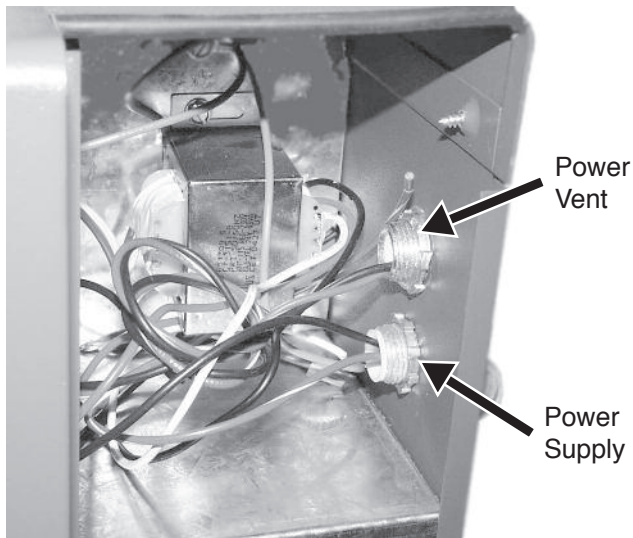

Fig. 13

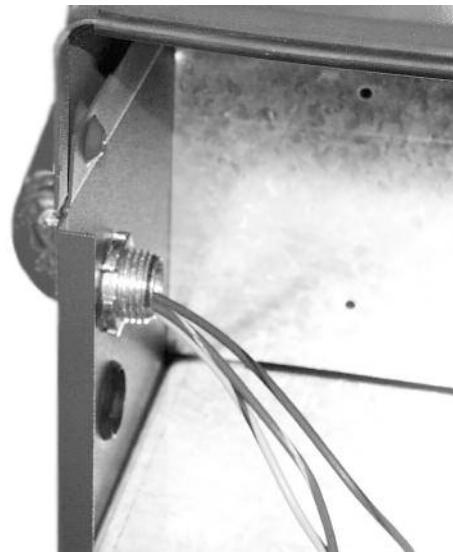

Fig. 14

**D-2 POWER VENT**  
010744 & 010745

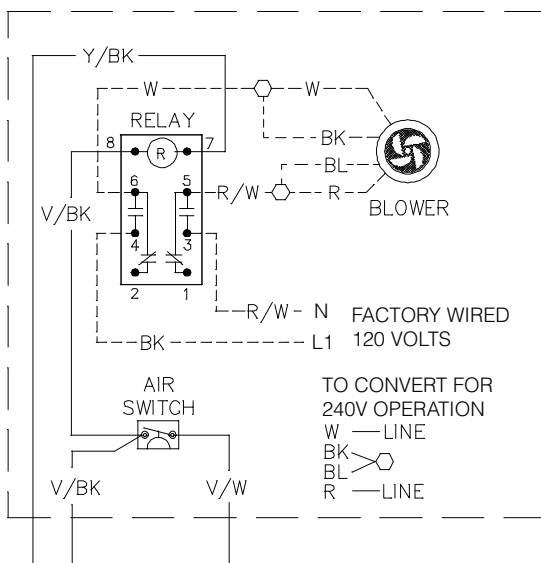

Fig. 15

**D-2 POWER VENT**  
009832 & 009833

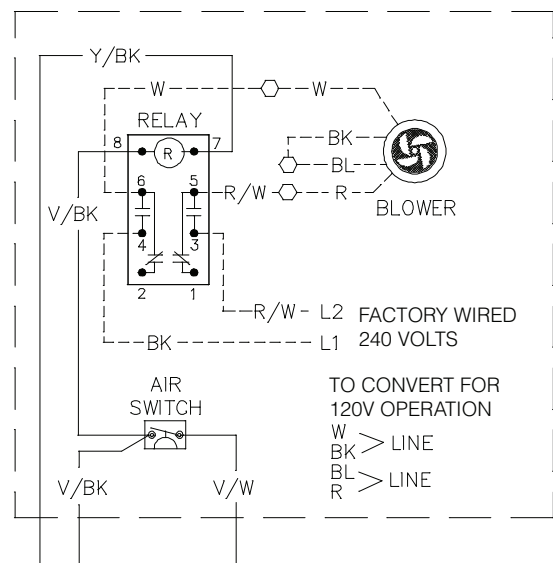

Fig. 16

## INSTALLATION (Continued)

17. Remove the (4) Phillips screws that hold the control panel to the heater and lower the control panel. See Fig. 17.
18. Remove and replace the 7/8" plug with the provided 7/8" grommet (located on the left side of the control panel). See Fig. 18.
19. Route the 24 VAC harness through the 7/8" grommet, See Fig. 19.
20. Continue to route the harness down through any available grommet hole. See Fig. 20.
21. Wire the harness along with the installed gas valve harness per the wiring diagram.
22. Reinstall the (4) Phillips screws that hold the control panel to the heater. See Fig. 17.
23. Place the front door back onto the heater. Refer to Fig. 1.

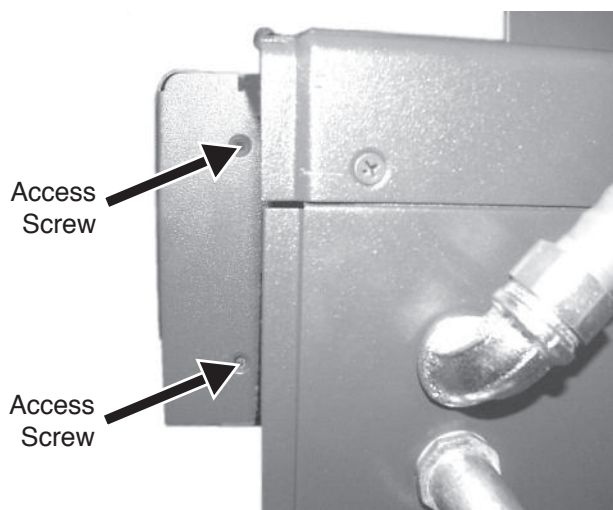

Fig. 17

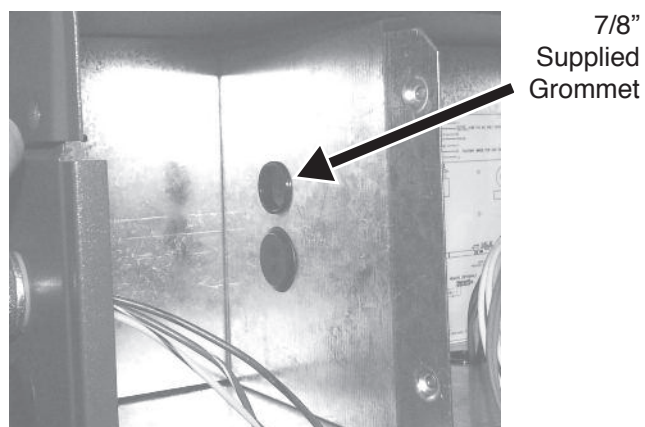

Fig. 18

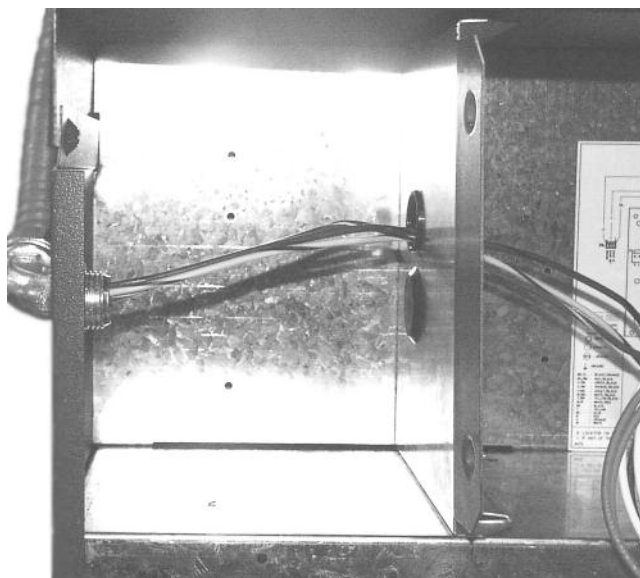

Fig. 19

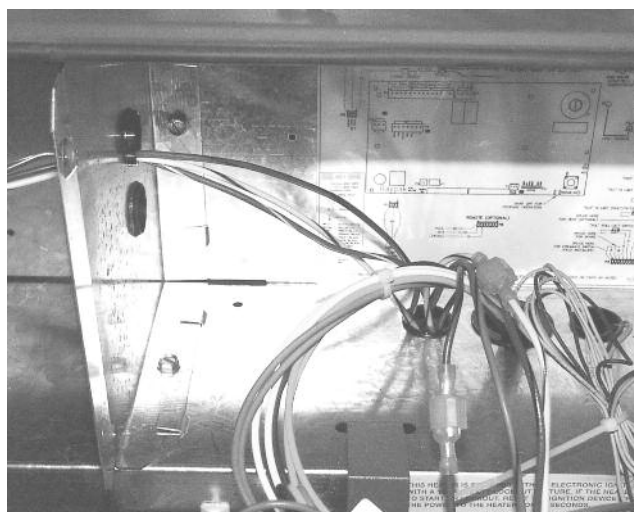

Fig. 20

**NOTE:** For Professional heaters, models 268 and 408, it may be necessary to reroute the flexible conduit to either side of the power vent.



## VENTING

The D-2 Power Vent operates with a positive vent static pressure and with a vent gas temperature that prevents excessive condensate production in the vent, and as such, is a CATEGORY III appliance.

The total length of run shall not exceed an equivalent length of 100 ft including the termination cap. For all cases, each 90° elbow reduces the maximum vent run by 10 ft and each 45° elbow reduces the run by 5 ft. The vent must be installed properly to prevent the flue gas leakage within the heater. The vent pipe must be suitable for use with Category III Appliances which have flue gas temperatures of less than 400°F. Care must be taken during the assembly to ensure that all joints are properly sealed.

For appliances installed in extremely cold climates, it is recommended that:

- a) The vent be installed with a slight upward slope of not more than 1/4" per foot of horizontal run to the vent terminal. In this case, an approved condensation trap must be installed per applicable codes.
- b) The vent be insulated through the length of the horizontal run.

The exit terminal of the D-2 Power Vent shall not be less than 7 ft above grade where located adjacent to public walkways. It must also be at least 3 ft above any forced air inlet located within a 10 ft radius.

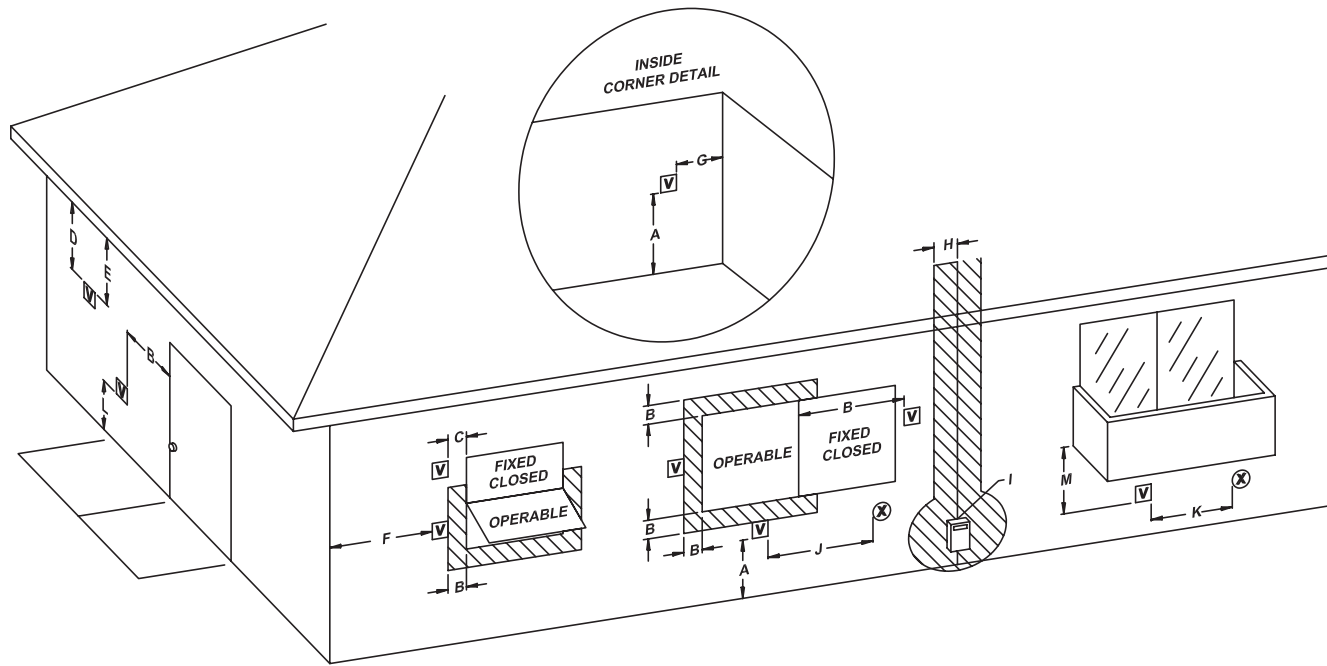

**Minimum Clearances from Vent/Air Inlet Terminations—Indoor and Outdoor Installations**

		<b>U.S. Installations<sup>1</sup></b>	<b>Canadian Installations<sup>2</sup></b>
A	Clearance above grade, veranda, porch, deck, or balcony	1 ft (30 cm)	1 ft (30 cm)
B	Clearance to window or door that may be opened	4 ft (1.2m) below or to side of opening; 1 foot (30 cm) above opening	3 ft (91 cm)
C	Clearance to permanently closed window	*	*
D	Vertical clearance to ventilated soffit located above the terminal within a horizontal distance of 2 ft (61cm) from the centerline of the terminal	5 ft (1.5m)	*
E	Clearance to unventilated soffit	*	*
F	Clearance to outside corner	*	*
G	Clearance to inside corner	6 ft (1.83m)	*
H	Clearance to each side of center line extended above meter/regulator assembly	*	3 ft (91 cm) within a height 15 ft above the meter/regulator assembly
I	Clearance to service regulator vent outlet	*	6 ft (1.83m)
J	Clearance to non-mechanical air supply inlet to building or the combustion air inlet to any other appliance	4 ft (1.2m) below or to side of opening; 1 ft (30 cm) above opening	3 ft (91 cm)
K	Clearance to mechanical air supply inlet	3 ft (91 cm) above if within 10 ft (3m) horizontally	6 ft (1.83m)
L	Clearance above paved sidewalk or paved driveway located on public property	7 ft (2.13m)	7 ft (2.13m) <sup>t</sup>
M	Clearance under veranda, porch, deck or balcony	*	12 in. (30 cm) <sup>TT</sup>

<sup>1</sup> In accordance with the current ANSI Z223.1/NFPA 54 National Fuel Gas Code

<sup>2</sup> In accordance with the current CAN/CSA-B149 Installation Codes

<sup>t</sup> Vent terminal shall not terminate directly above sidewalk or paved driveway located between 2 single family dwellings that serves both dwellings

<sup>TT</sup> Permitted only if veranda, porch, deck, or balcony is fully open on a minimum of two sides beneath the floor and top of terminal and underside of veranda, porch, deck or balcony is greater than 1 ft (30cm)

\* Clearances in accordance with local installation codes and the requirements of the gas supplier

**Vent/Air Inlet Termination Clearances**

## CLEARANCES - INDOOR INSTALLATION

### Vertical & Horizontal Venting

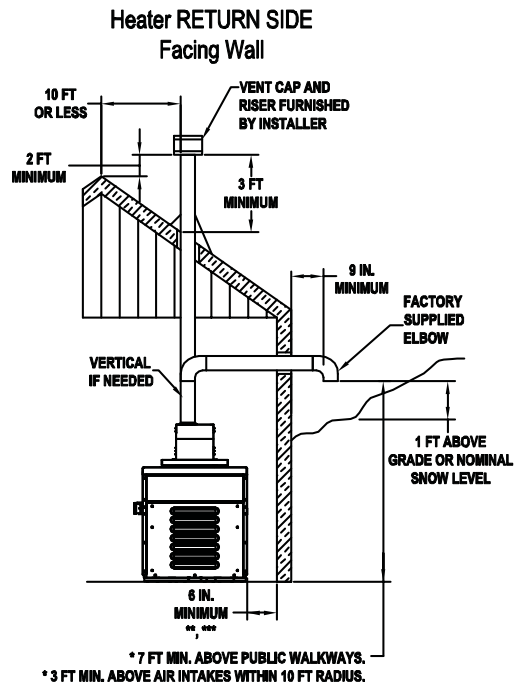
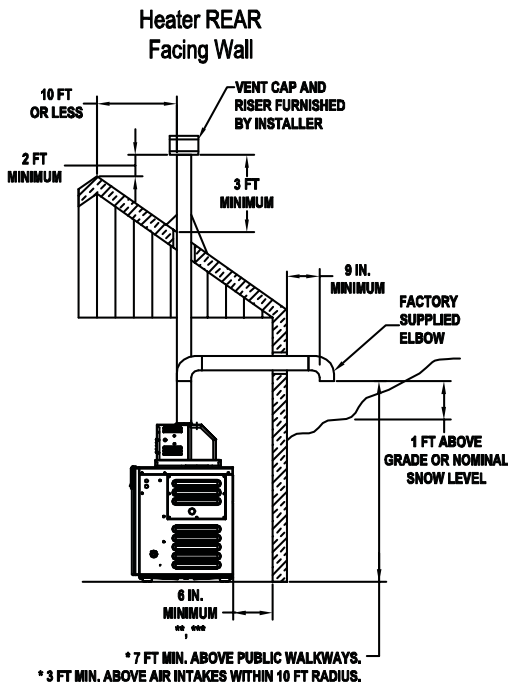
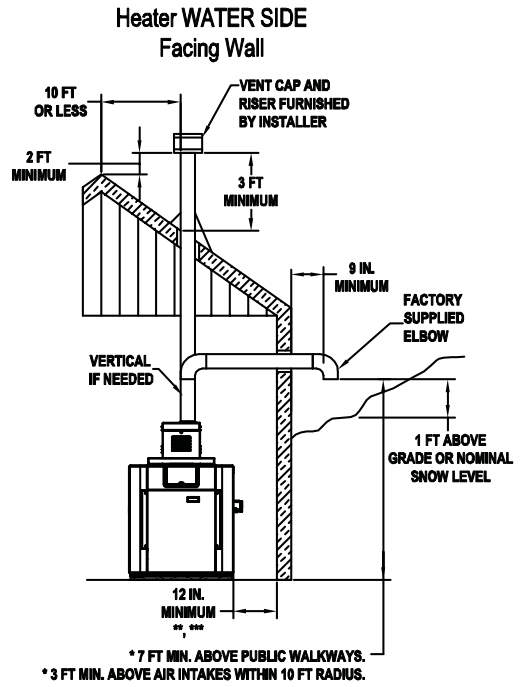
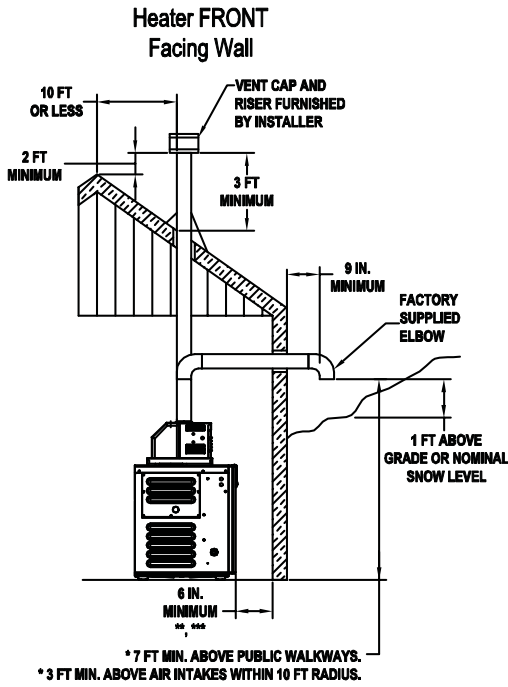

\*USE VERTICAL VENT PIPE TO MEET MINIMUM HEIGHT REQUIREMENTS.  
 \*\* MUST BE 4 FT AWAY FROM ANY WINDOW, DOOR, OR GRAVITY AIR INLET.  
 \*\*\* RECOMMENDED SERVICE CLEARANCE IS 24 IN. FROM THE FRONT OF THE HEATER TO A WALL;  
 18 IN. FROM THE WATER SIDE TO A WALL.

## CLEARANCES - OUTDOOR INSTALLATION

### Vertical Venting

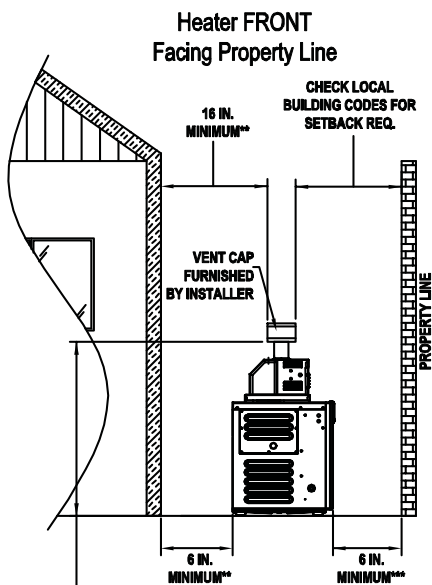

- \* 7 FT MIN. ABOVE PUBLIC WALKWAYS.
- \*\* 3 FT MIN. ABOVE AIR INTAKES WITHIN 10 FT RADIUS.
- \*\* 43 3/4 IN. MINIMUM FROM PAD (LOW NOX HEATERS).
- \*\* 50 IN. MINIMUM FROM PAD (ATMOSPHERIC HEATERS).

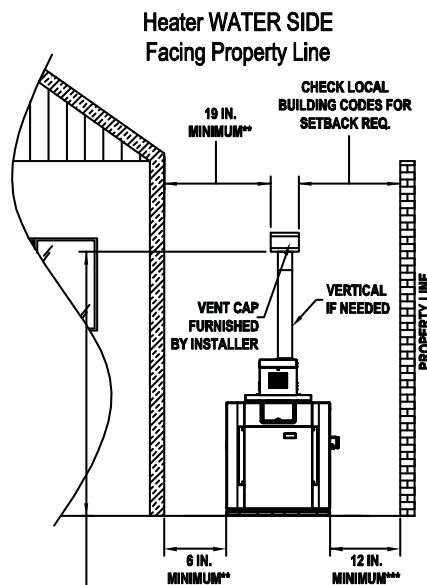

- \* 7 FT MIN. ABOVE PUBLIC WALKWAYS.
- \*\* 3 FT MIN. ABOVE AIR INTAKES WITHIN 10 FT RADIUS.
- \*\* 43 3/4 IN. MINIMUM FROM PAD (LOW NOX HEATERS).
- \*\* 50 IN. MINIMUM FROM PAD (ATMOSPHERIC HEATERS).

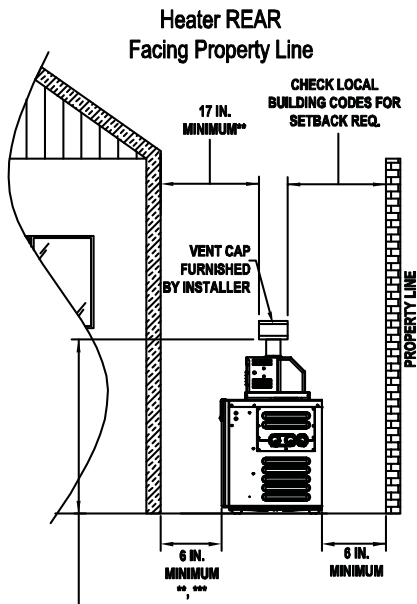

- \* 7 FT MIN. ABOVE PUBLIC WALKWAYS.
- \*\* 3 FT MIN. ABOVE AIR INTAKES WITHIN 10 FT RADIUS.
- \*\* 43 3/4 IN. MINIMUM FROM PAD (LOW NOX HEATERS).
- \*\* 50 IN. MINIMUM FROM PAD (ATMOSPHERIC HEATERS).

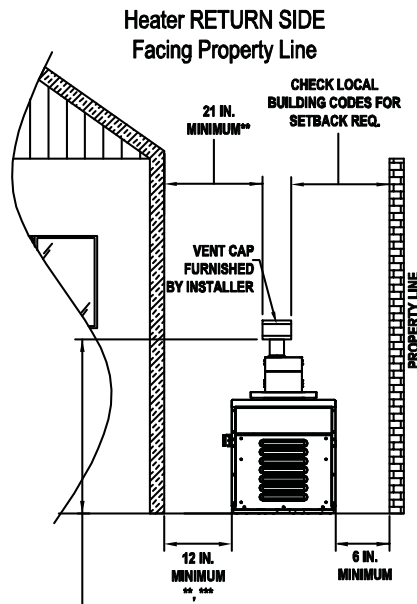

- \* 7 FT MIN. ABOVE PUBLIC WALKWAYS.
- \*\* 3 FT MIN. ABOVE AIR INTAKES WITHIN 10 FT RADIUS.
- \*\* 43 3/4 IN. MINIMUM FROM PAD (LOW NOX HEATERS).
- \*\* 50 IN. MINIMUM FROM PAD (ATMOSPHERIC HEATERS).

\*USE VERTICAL VENT PIPE TO MEET MINIMUM HEIGHT REQUIREMENTS.  
 \*\* MUST BE 4 FT AWAY FROM ANY WINDOW, DOOR, OR GRAVITY AIR INLET.  
 \*\*\* RECOMMENDED SERVICE CLEARANCE IS 24 IN. FROM THE FRONT OF THE HEATER TO A WALL;  
 18 IN. FROM THE WATER SIDE TO A WALL.

## CLEARANCES - OUTDOOR INSTALLATION

### Horizontal Venting

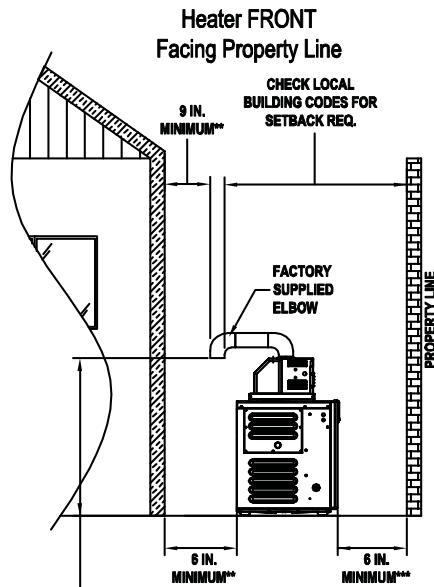

- \* 7 FT MIN. ABOVE PUBLIC WALKWAYS.
- \* 3 FT MIN. ABOVE AIR INTAKES WITHIN 10 FT RADIUS.
- \* 43 3/4 IN. MINIMUM FROM PAD (LOW NOX HEATERS).
- \* 50 IN. MINIMUM FROM PAD (ATMOSPHERIC HEATERS).

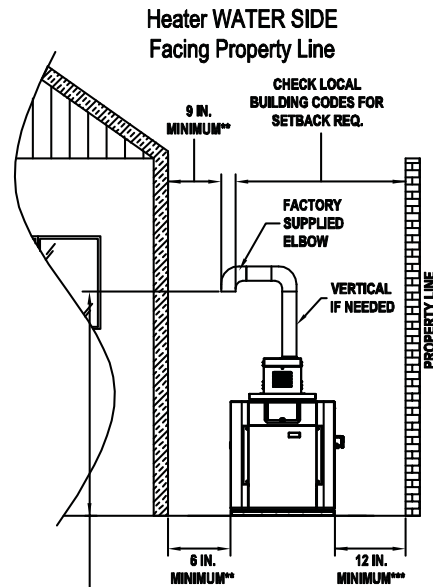

- \* 7 FT MIN. ABOVE PUBLIC WALKWAYS.
- \* 3 FT MIN. ABOVE AIR INTAKES WITHIN 10 FT RADIUS.
- \* 43 3/4 IN. MINIMUM FROM PAD (LOW NOX HEATERS).
- \* 50 IN. MINIMUM FROM PAD (ATMOSPHERIC HEATERS).

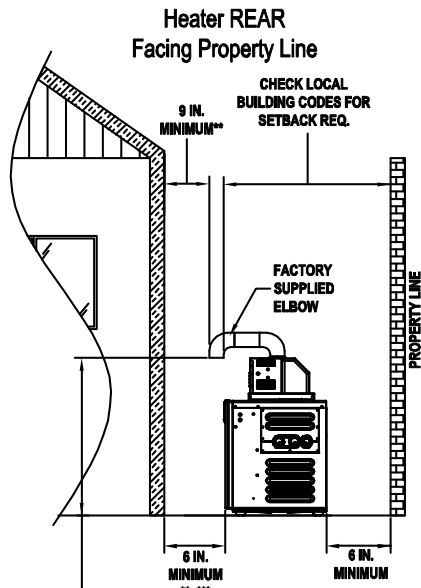

- \* 7 FT MIN. ABOVE PUBLIC WALKWAYS.
- \* 3 FT MIN. ABOVE AIR INTAKES WITHIN 10 FT RADIUS.
- \* 43 3/4 IN. MINIMUM FROM PAD (LOW NOX HEATERS).
- \* 50 IN. MINIMUM FROM PAD (ATMOSPHERIC HEATERS).

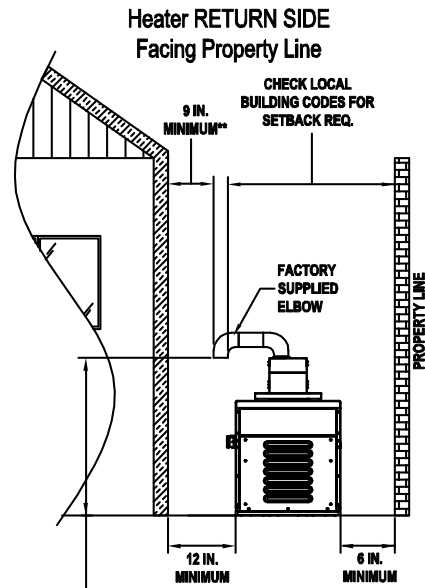

- \* 7 FT MIN. ABOVE PUBLIC WALKWAYS.
- \* 3 FT MIN. ABOVE AIR INTAKES WITHIN 10 FT RADIUS.
- \* 43 3/4 IN. MINIMUM FROM PAD (LOW NOX HEATERS).
- \* 50 IN. MINIMUM FROM PAD (ATMOSPHERIC HEATERS).

\*USE VERTICAL VENT PIPE TO MEET MINIMUM HEIGHT REQUIREMENTS.  
 \*\* MUST BE 4 FT AWAY FROM ANY WINDOW, DOOR, OR GRAVITY AIR INLET.  
 \*\*\* RECOMMENDED SERVICE CLEARANCE IS 24 IN. FROM THE FRONT OF THE HEATER TO A WALL;  
 18 IN. FROM THE WATER SIDE TO A WALL.

# CLEARANCES - OUTDOOR INSTALLATION

## Horizontal Venting

TOP VIEW

Heater REAR

Facing Property Line

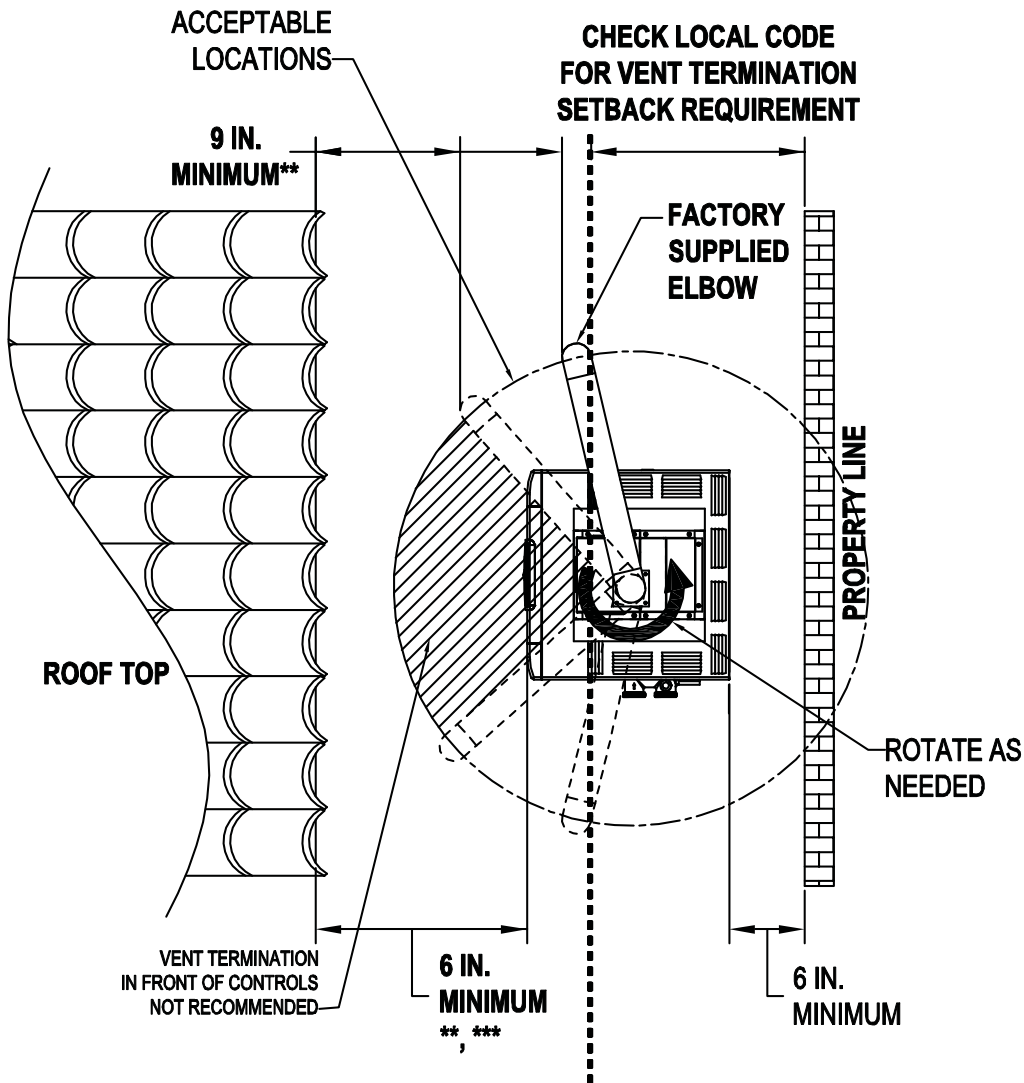

\*USE VERTICAL VENT PIPE TO MEET MINIMUM HEIGHT REQUIREMENTS.  
\*\* MUST BE 4 FT AWAY FROM ANY WINDOW, DOOR, OR GRAVITY AIR INLET.  
\*\*\* RECOMMENDED SERVICE CLEARANCE IS 24 IN. FROM THE FRONT OF THE HEATER TO A WALL;  
18 IN. FROM THE WATER SIDE TO A WALL.

NOTE: FOR EXHAUST TERMINATION, MINIMUM CLEARANCES FROM COMBUSTIBLES SHOULD BE MAINTAINED SUCH AS FROM VEGETATION.

## SEQUENCE OF OPERATION

On call for heat, the PC board will go through its safety chain (water pressure switch, high limit 1 & 2, roll-out, etc.). When the safety chain is closed, the IID pilot will begin to spark and the pilot gas valve will open. A flame will be lit at the pilot assembly. When an acceptable signal is sent back to the PC board, proving the rectification, the D-2 Power Vent blower will start. When the blower comes up to speed, a draft proving switch will close to allow the main gas valve on the heater to open. Note: On Low NOx units, the main gas valve & combustion blower will turn on simultaneously. A heater with a D-2 Power Vent will continue to operate until call for heat is satisfied.

## DRAFT-PROVING SWITCH

The draft-proving switch ensures that the blower is operating. Once the D-2 Power Vent is wired to the heater, the switch does not allow the PC board to open the main gas valve, unless it is closed.



## WIRING

The D-2 Power Vent includes a wire harness which provides quick connections with the respective controls in the appliance control box. The harness is of sufficient length to fit the unit for which it is sized.

Reference the connection diagrams on pages 17 & 18 or the wiring diagrams on pages 19 through 21 for actual connections.

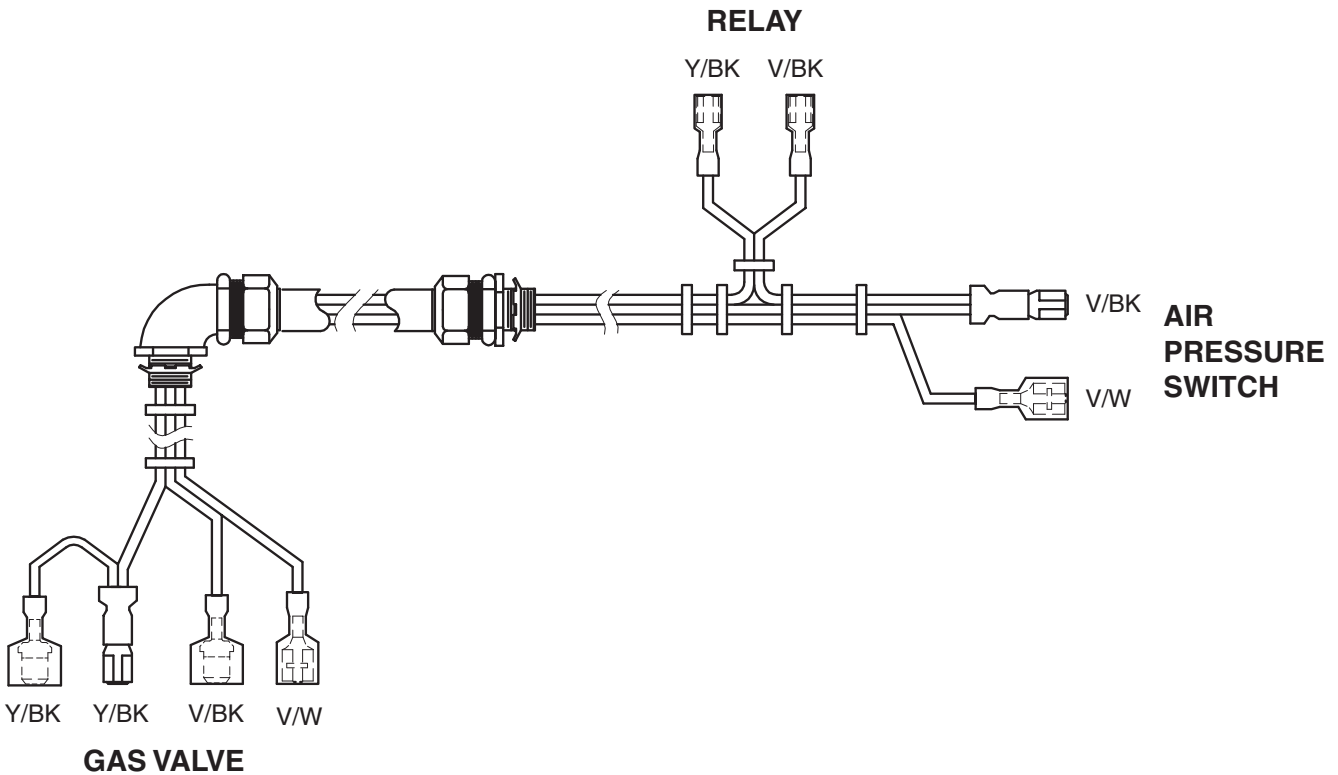



# WIRING (Continued)

## MODELS 207, 267, 337, 407 EQUIPPED WITH HONEYWELL GAS VALVE

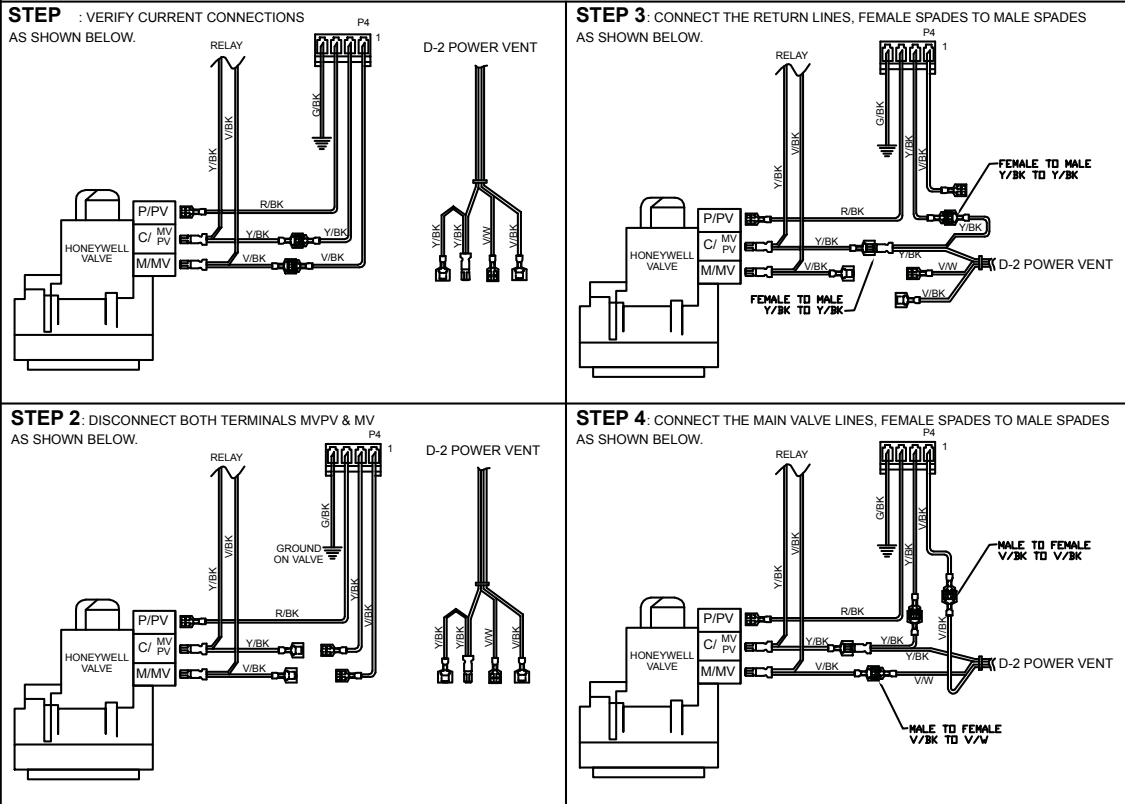

## MODELS 207, 267, 337, 407 EQUIPPED WITH INVENSYS/ROBERTSHAW GAS VALVE

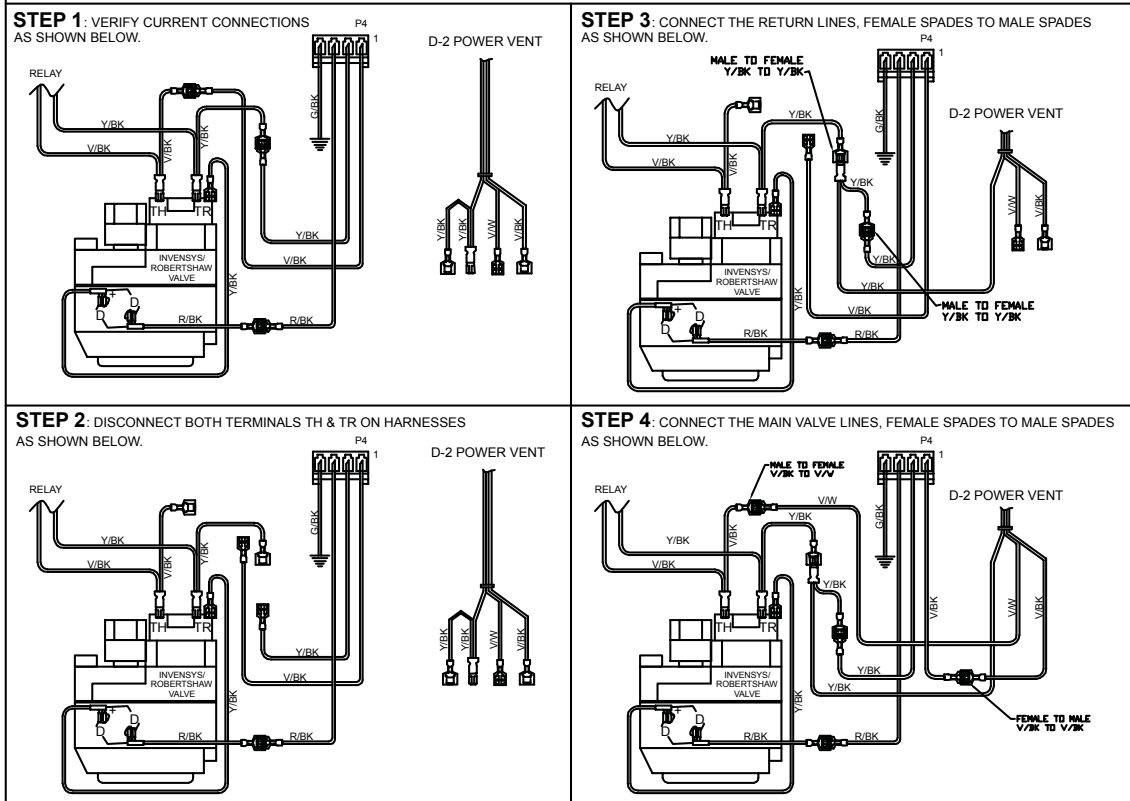

# WIRING (Continued)

## MODELS 206, 266, 268, 336, 406, 408 EQUIPPED WITH HONEYWELL GAS VALVE

**STEP 1:** VERIFY CURRENT CONNECTIONS AS SHOWN BELOW.

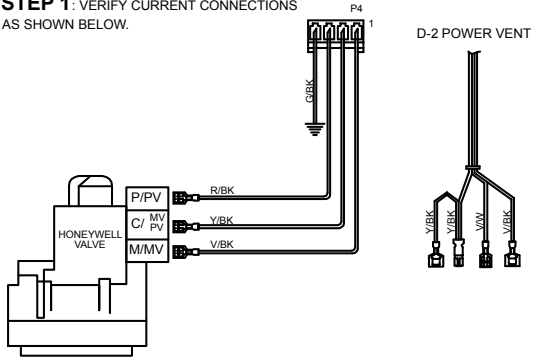

**STEP 3:** CONNECT THE RETURN LINE, FEMALE SPADE TO MALE SPADE AS SHOWN BELOW.

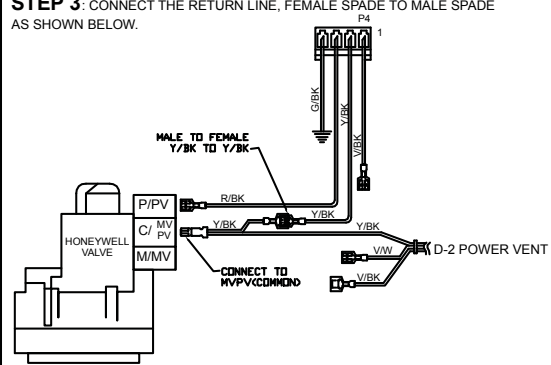

**STEP 2:** DISCONNECT BOTH TERMINALS MVPV & MV FROM VALVE AS SHOWN BELOW.

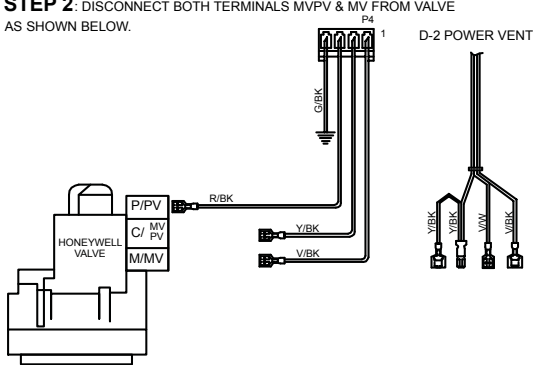

**STEP 4:** CONNECT THE MAIN VALVE LINE, FEMALE SPADE TO MALE SPADE AS SHOWN BELOW.

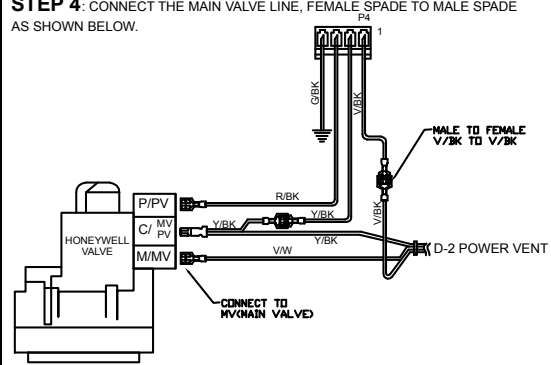

## MODELS 206, 266, 268, 336, 406, 408 EQUIPPED WITH INVENSYS/ROBERTSHAW GAS VALVE

**STEP 1:** VERIFY CURRENT CONNECTIONS AS SHOWN BELOW.

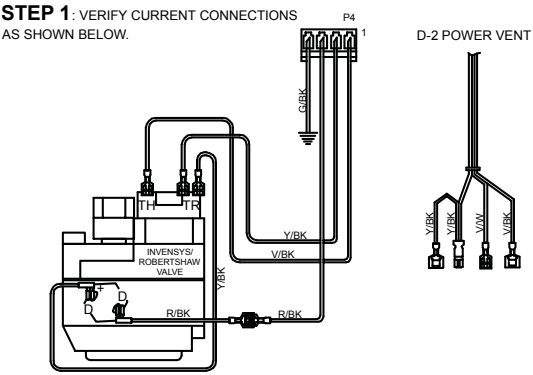

**STEP 3:** CONNECT THE RETURN LINE, FEMALE SPADE TO MALE SPADE AS SHOWN BELOW.

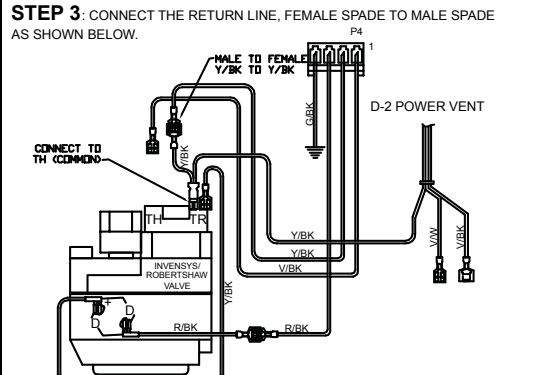

**STEP 2:** DISCONNECT BOTH TERMINALS TH & TR AS SHOWN BELOW.

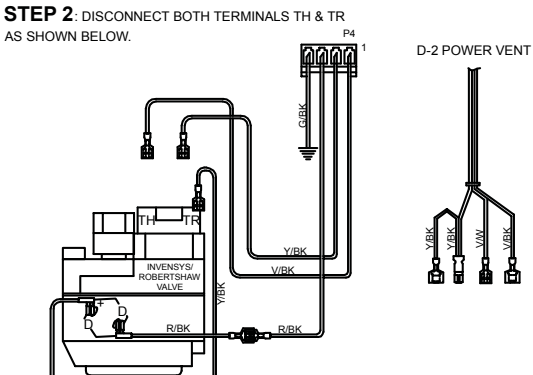

**STEP 4:** CONNECT THE MAIN VALVE LINE, FEMALE SPADE TO MALE SPADE AS SHOWN BELOW.

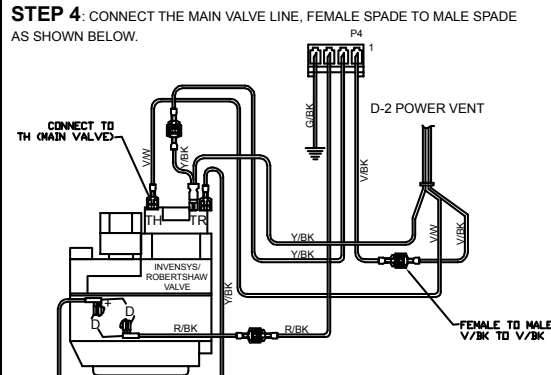

# WIRING DIAGRAM - MODELS 207A, 267A, 337A, 407A

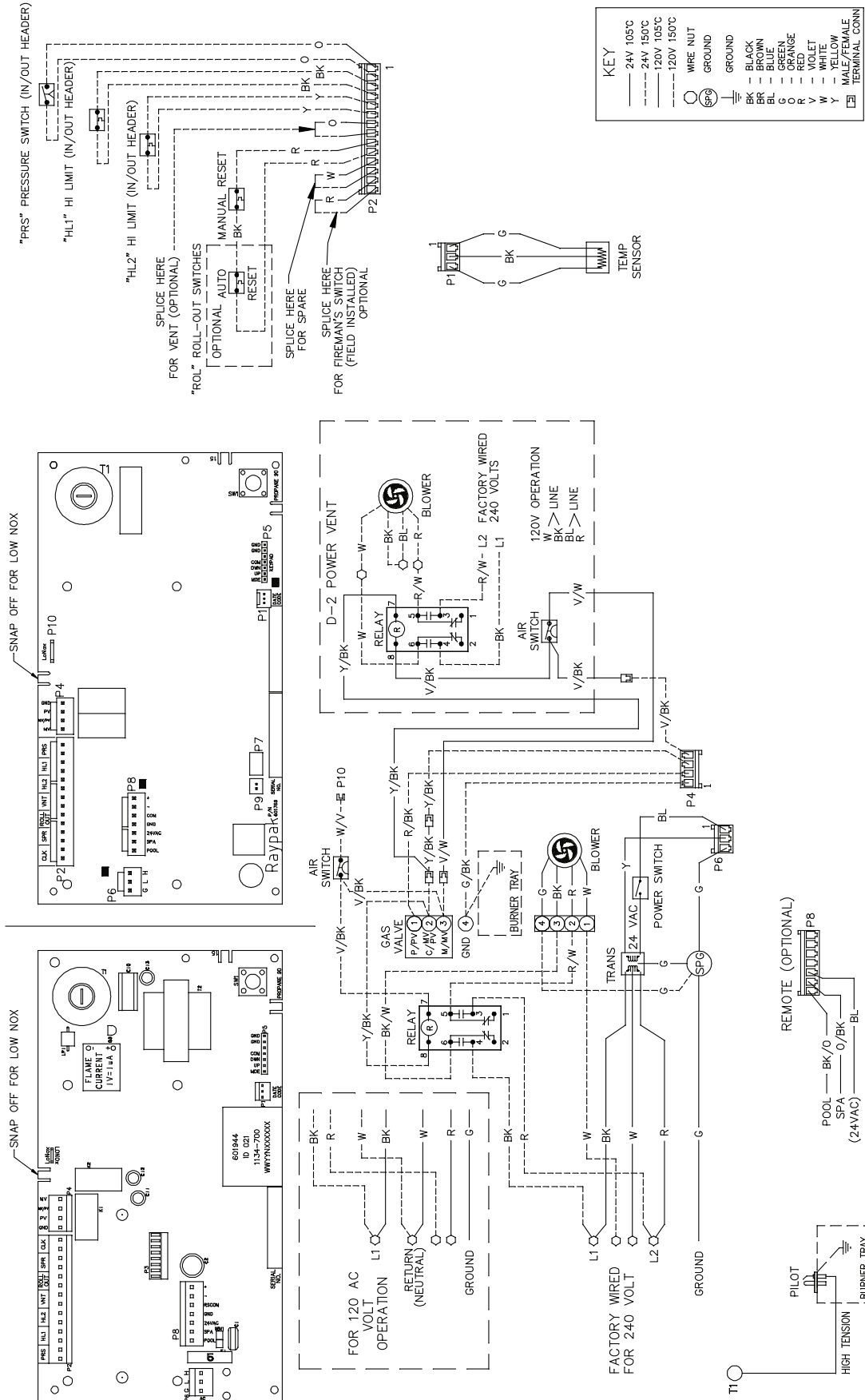

# WIRING DIAGRAM - MODELS 206A, 266A, 336A, 406A

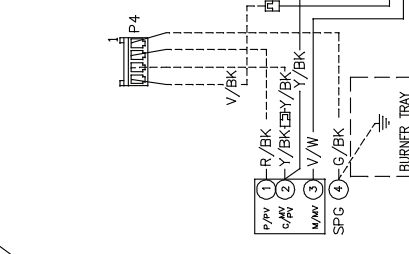
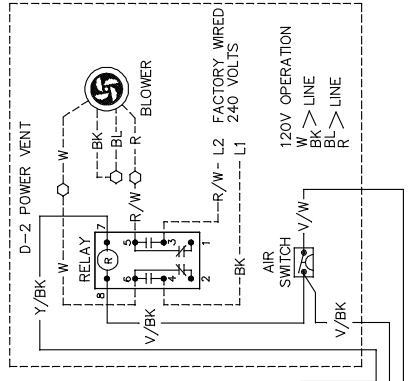
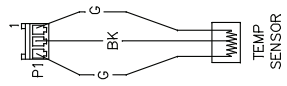
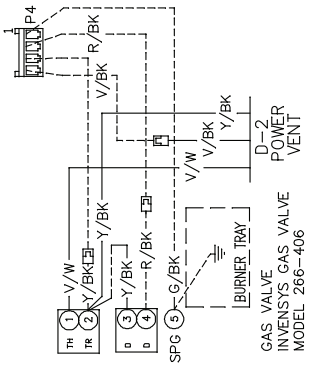
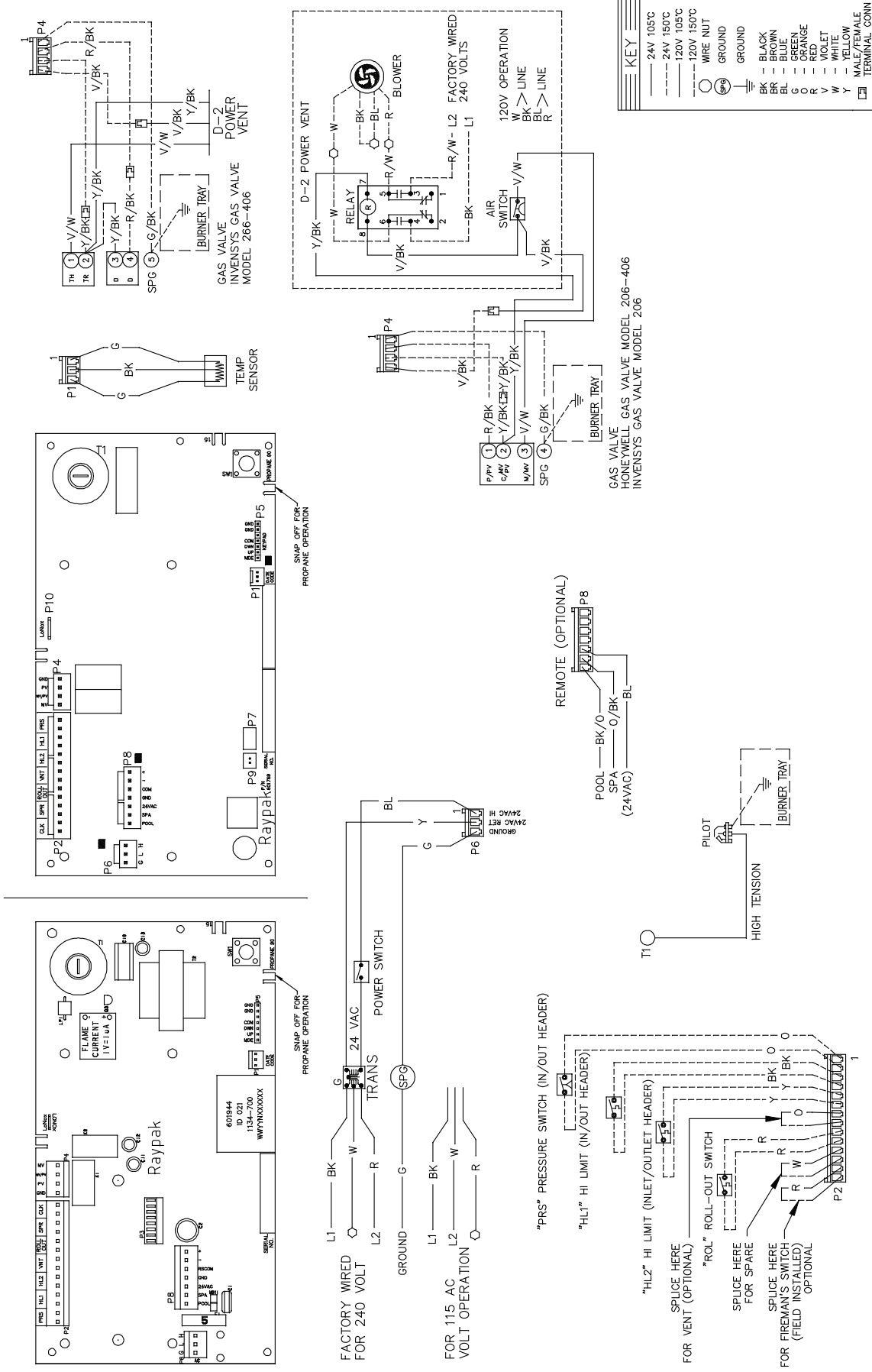

KEY	
—	24V 105°C
- - -	24V 150°C
- - -	120V 105°C
- - -	120V 150°C
○	WIRE NUT
⊕	GROUND
⊕	GROUND
BK	BLACK
BL	BLUE
BR	BROWN
G	GREEN
O	ORANGE
R	RED
V	VIOLET
W	WHITE
Y	YELLOW
⊞	MALE/FEMALE TERMINAL CONN

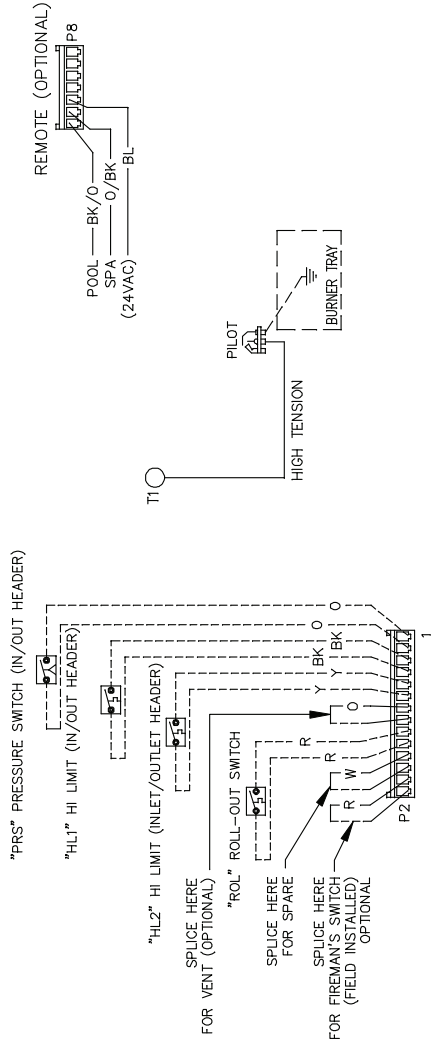
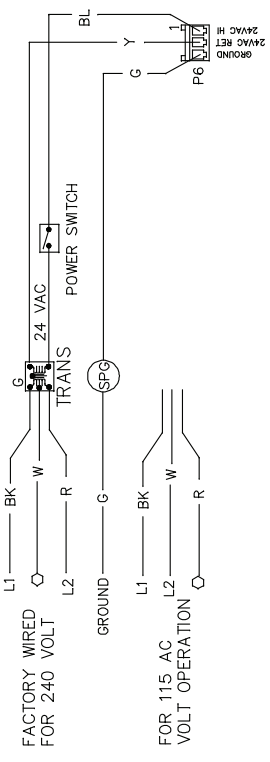

# WIRING DIAGRAM - MODELS 268, 408

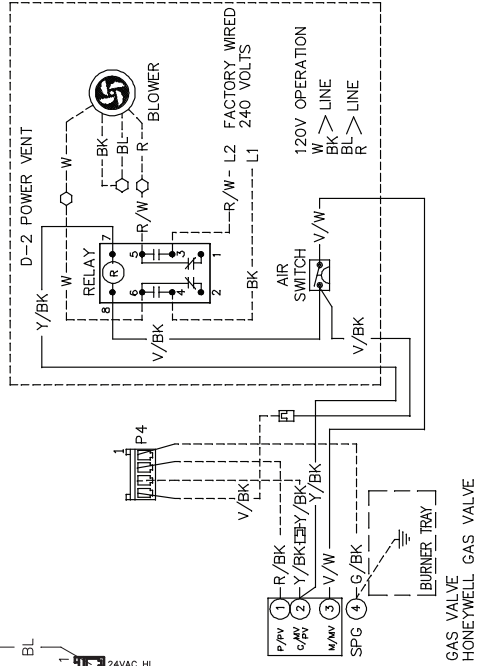
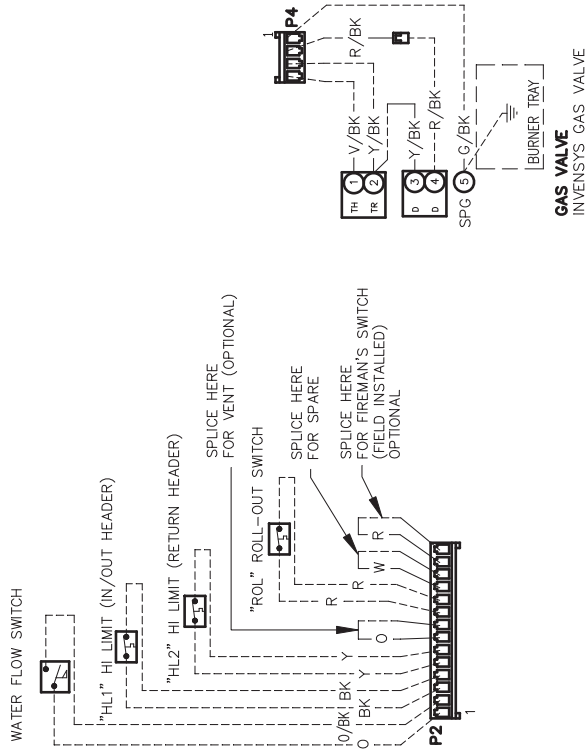
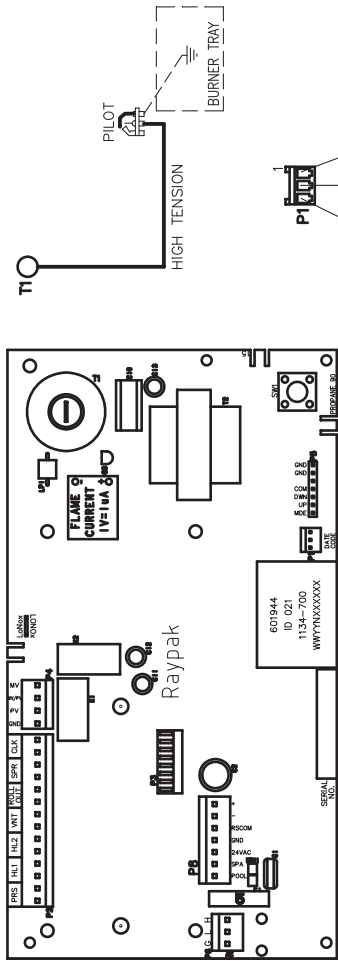

KEY	
—	24V 105°C
- - -	24V 150°C
—	120V 105°C
- - -	120V 150°C
○	WIRE NUT
⊕	GROUND
□	GROUND
BK	BLACK
BR	BROWN
BL	BLUE
GR	GREEN
OR	ORANGE
RD	RED
VT	VIOLET
WH	WHITE
YL	YELLOW
Y	MALE/FEMALE TERMINAL CONN

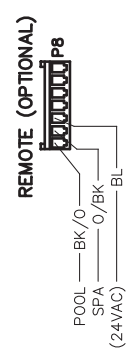
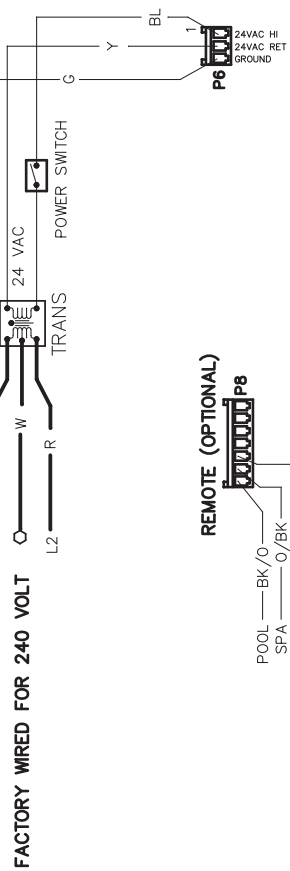

## REPLACEMENT PARTS

**NOTE:** To supply you with the correct part, it is important that you supply the heater model number, serial number and type of gas when applicable.

Any part returned for replacement under standard company warranties must be properly tagged with a return parts tag, completely filled in with the heater serial number, model number, etc., and shipped to the Company freight prepaid.

If determined defective by the Company and within warranty, a like part or equal substitution will be returned, freight collect. Credit will not be issued.

### MANUFACTURER:

2151 EASTMAN AVENUE  
OXNARD, CA 93030

## ILLUSTRATED PARTS LIST

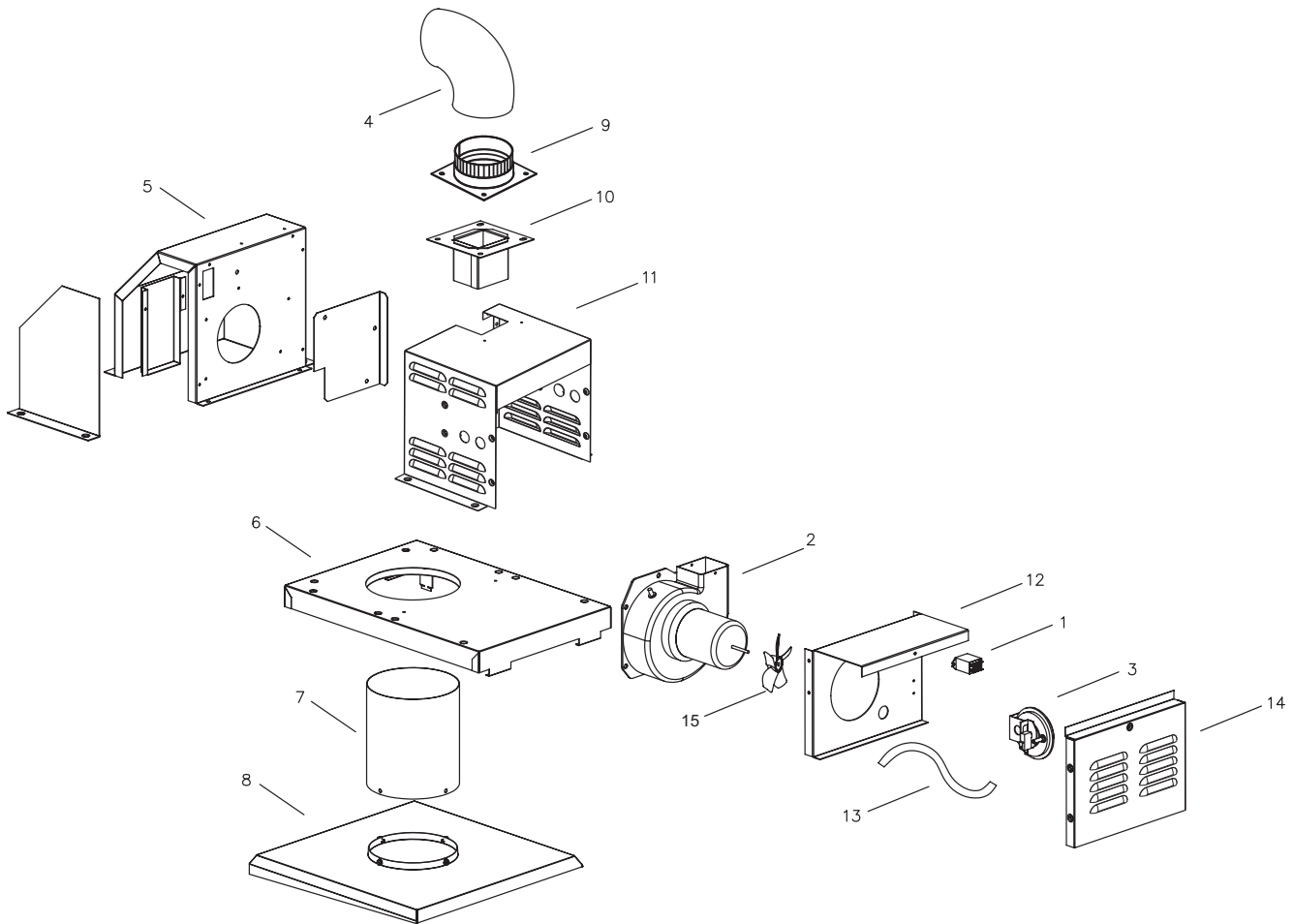

Call Out	Description	206/207	266/267/268	336/366	406/407/408
1	DPDT Relay	008784F	008784F	008784F	008784F
2	Blower	008156F	008156F	008156F	008156F
3	N.O. Air Pressure Switch	008062F	008062F	008135F	008135F
4	4"-90° Elbow w/Screen	010827F	010827F	010827F	010827F
5	Combustion Flue Box				
	Green	008682F	008682F	008683F	008683F
	Cool Dark Gray	013854F	013854F	013855F	013855F
6	Base Assembly	010821F	010821F	010822F	010822F
7	Flue Collar	008686F	008686F	008686F	008686F
8	Flue Adapter	010823F	010823F	010824F	010824F
9	4" Flange	008689F	008689F	008689F	008689F
10	Blower Adapter				
	Green	008690F	008690F	008690F	008690F
	Cool Dark Gray	013858F	013858F	013858F	013858F
11	Control Cover				
	Green	008691F	008691F	008691F	008691F
	Cool Dark Gray	013856F	013856F	013856F	013856F
12	Control Swaybrace	008692F	008692F	008692F	008692F
13	Silicone Hose	008693F	008693F	008693F	008693F
14	Front Panel				
	Green	008694F	008694F	008694F	008694F
	Cool Dark Gray	013857F	013857F	013857F	013857F
15	Blower Cooling Fan	011549F	011549F	011549F	011549F



**[www.raypak.com](http://www.raypak.com)**

Raypak, Inc., 2151 Eastman Avenue, Oxnard, CA 93030 (805) 278-5300 Fax (805) 278-5468  
Litho in U.S.A.