

STEP OPTIONS

STEP OPTION 1

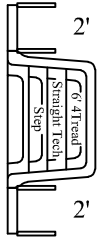

STEP OPTION 2



STEP OPTION 3

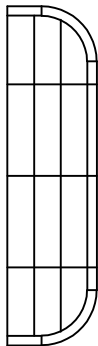

P-ST-PB-1683-2R

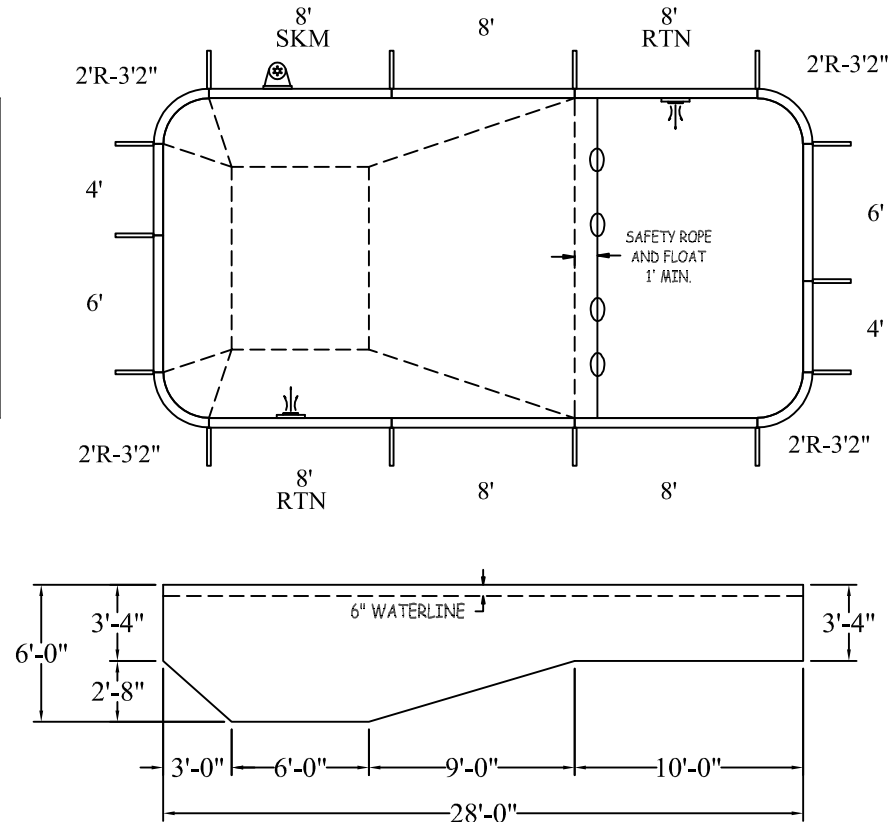
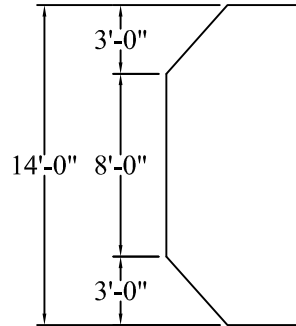

NON DIVING

RECTANGLE 2FT RAD

DATE: 01/01/2019

PERIMETER: 80'-8" LIN.FT.

REVISION:

SURFACE (ft²): 388.5664

SCALE: N.T.S.

LINER (ft²): 392.0000

APPROX. WATER VOLUME: 40 900 LITRES

COVER (ft²): 480.0000 Standard

ATLAS SERIES

WARNING

SWIMMING POOLS ARE DANGEROUS WHEN USED IMPROPERLY. CONSULT YOUR DEALER FOR INFORMATION ON THE SAFE USE OF SWIMMING POOLS. IT IS THE RESPONSIBILITY OF TOWN OFFICIALS, BUILDERS AND HOME OWNERS TO FOLLOW ALL SAFETY RECOMMENDATIONS OF LOCAL ORDINANCES AND EQUIPMENT MANUFACTURERS FOR DIVING & SLIDING EQUIPMENT REFER TO THE MANUFACTURER'S INSTRUCTIONS TO CORRECTLY POSITION & INSTALL EQUIPMENT.

14-0 X 28-0

	A	B	C	D
1	4'-5 3/4"	28'-0 3/4"	32'-3"	16'-6"
2	28'-0 3/4"	4'-5 3/4"	16'-6"	32'-3"
3	30'-3 1/4"	4'-5 3/4"	14'-1 3/4"	33'-1 1/4"
4	33'-1 1/4"	14'-1 3/4"	4'-5 3/4"	30'-3 1/4"
5	32'-3"	16'-6"	4'-5 3/4"	28'-0 3/4"
6	16'-6"	32'-3"	28'-0 3/4"	4'-5 3/4"
7	14'-1 3/4"	33'-1 1/4"	30'-3 1/4"	4'-5 3/4"
8	4'-5 3/4"	30'-3 1/4"	33'-1 1/4"	14'-1 3/4"
S1	20'-1 1/4"	12'-2"	20'-0"	25'-7 1/4"
S2	25'-7 1/4"	20'-0"	12'-2"	20'-1 1/4"
H1	11'-2 1/4"	21'-1 1/4"	26'-4 3/4"	19'-5"
H2	19'-5"	26'-4 3/4"	21'-1 1/4"	11'-2 1/4"
A	-	32'-0"	36'-8 1/2"	18'-0"

DIAGONALS	
1 to 2	24'-0"
1 to 3	26'-1"
1 to 4	28'-7 3/4"
1 to 5	27'-9 1/2"
1 to 6	14'-0"
1 to 7	12'-2"
1 to 8	2'-10"
2 to 3	2'-10"
2 to 4	12'-2"
2 to 5	14'-0"
2 to 6	27'-9 1/2"
2 to 7	28'-7 3/4"
2 to 8	26'-1"
3 to 4	10'-0"
3 to 5	12'-2"
3 to 6	28'-7 3/4"
3 to 7	29'-8 3/4"
3 to 8	28'-0"
4 to 5	2'-10"
4 to 6	26'-1"
4 to 7	28'-0"
4 to 8	29'-8 3/4"
5 to 6	24'-0"
5 to 7	26'-1"
5 to 8	28'-7 3/4"
6 to 7	2'-10"
6 to 8	12'-2"
7 to 8	10'-0"
S1 to S2	14'-0"
S1 to H1	9'-0"
S1 to H2	16'-7 3/4"
S2 to H1	16'-7 3/4"
S2 to H2	9'-0"
H1 to H2	14'-0"

