

STEP OPTIONS

STEP OPTION 1

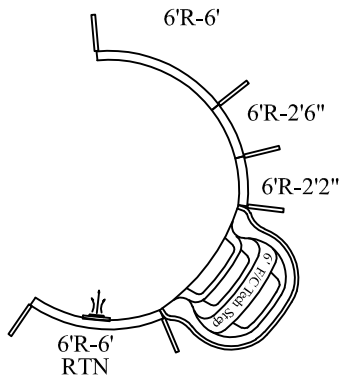

STEP OPTION 2

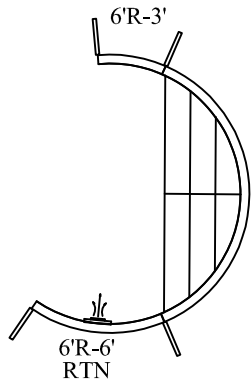

P-ST-PB-6003R

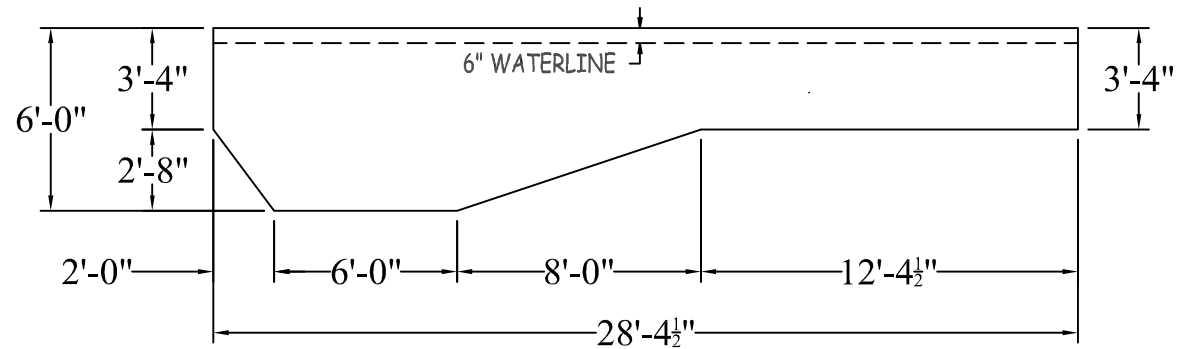
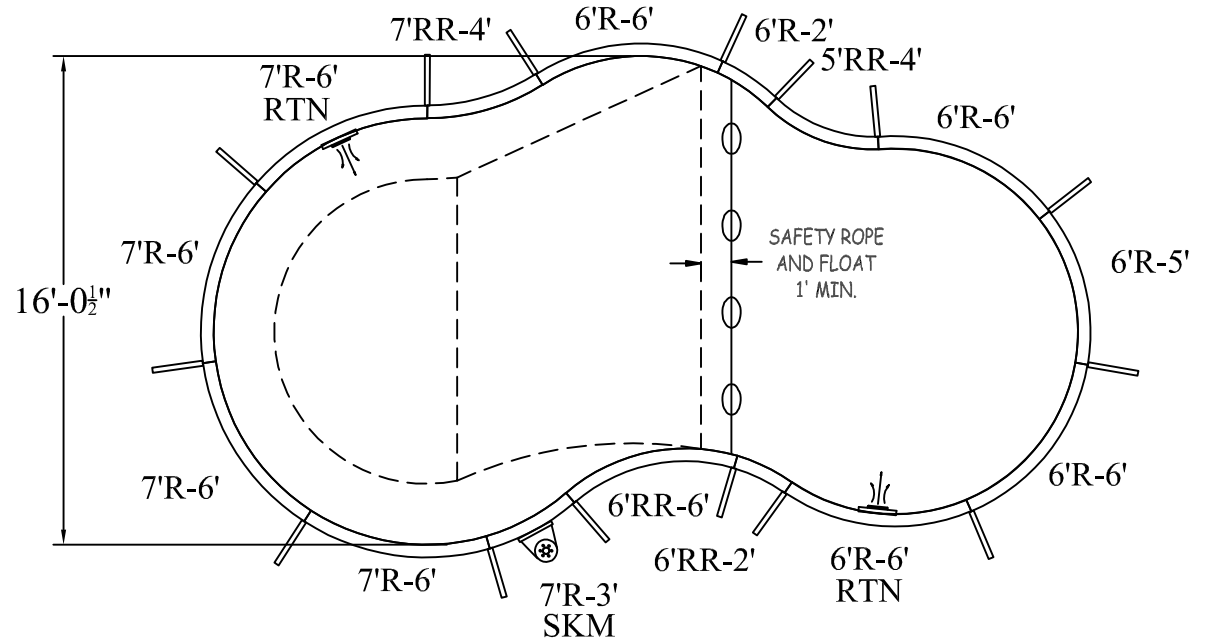
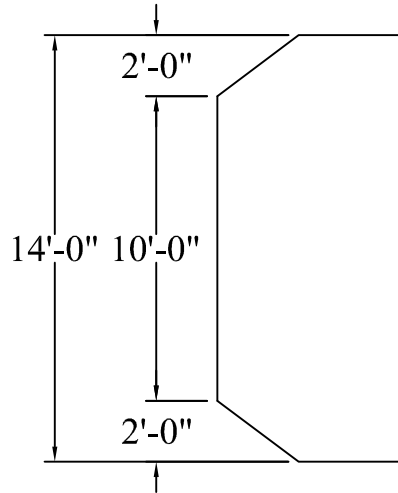

NON DIVING

MOUNTAIN LAKE

DATE: 01/01/2019

PERIMETER: 74'-0" LIN.FT.

REVISION:

SURFACE (ft²): 331.9002

SCALE: N.T.S.

LINER (ft²): 397.2486

APPROX. WATER VOLUME: 35 500 LITRES

COVER (ft²): 599.5310 FREEFORM

ATLAS SERIES

WARNING

SWIMMING POOLS ARE DANGEROUS WHEN USED IMPROPERLY. CONSULT YOUR DEALER FOR INFORMATION ON THE SAFE USE OF SWIMMING POOLS. IT IS THE RESPONSIBILITY OF TOWN OFFICIALS, BUILDERS AND HOME OWNERS TO FOLLOW ALL SAFETY RECOMMENDATIONS OF LOCAL ORDINANCES AND EQUIPMENT MANUFACTURERS FOR DIVING & SLIDING EQUIPMENT REFER TO THE MANUFACTURER'S INSTRUCTIONS TO CORRECTLY POSITION & INSTALL EQUIPMENT.

14-0 X 16-1 X 28-5 LEFT

	A	B	C	D		A	B	C	D
1	14'-3"	25'-10 1/4"	25'-0 1/2"	12'-8 3/4"	S1	18'-1 3/4"	14'-6 3/4"	22'-9 3/4"	25'-3"
2	26'-9"	13'-7 1/2"	12'-0 1/2"	25'-11 3/4"	S2	23'-4 1/2"	20'-8 1/2"	15'-3 1/4"	18'-8 3/4"
3	17'-11"	18'-2 1/4"	20'-3 1/2"	20'-0 3/4"	H1	10'-9 1/4"	22'-8 3/4"	27'-6 1/2"	18'-11"
4	9'-6 1/4"	23'-6 1/4"	32'-9 1/4"	24'-8 1/2"	H2	20'-6 3/4"	28'-8 1/2"	22'-5 3/4"	10'-2 1/2"
5	23'-7 3/4"	8'-8 3/4"	21'-9 1/2"	30'-11 1/2"	A	-	32'-4 1/2"	38'-1"	20'-0 1/2"
6	27'-3"	25'-7 1/2"	14'-10 3/4"	17'-6 1/4"					
7	9'-10 3/4"	23'-8 1/2"	28'-3 3/4"	18'-4 1/2"					
8	13'-1 3/4"	19'-9 1/2"	25'-11 3/4"	21'-4 1/2"					
9	20'-6 1/4"	12'-8 3/4"	20'-4 3/4"	26'-0"					
10	24'-4 1/2"	9'-11"	17'-3"	28'-1 3/4"					
11	26'-4 3/4"	19'-7 1/2"	12'-1"	21'-4 1/2"					
12	21'-3"	24'-10 3/4"	19'-2"	14'-1"					

DIAGONALS		3 to 12	8'-8 1/4"
1 to 2	15'-4 1/2"	4 to 5	14'-11"
1 to 3	7'-8"	4 to 6	25'-3 1/2"
1 to 4	14'-0"	4 to 7	7'-0"
1 to 5	18'-3 3/4"	4 to 8	7'-0"
1 to 6	13'-0"	4 to 9	12'-11 3/4"
1 to 7	7'-0"	4 to 10	16'-10"
1 to 8	8'-11 1/2"	4 to 11	22'-4 3/4"
1 to 9	13'-4 3/4"	4 to 12	19'-9 3/4"
1 to 10	16'-0"	5 to 6	21'-8 1/2"
1 to 11	12'-11 3/4"	5 to 7	15'-2"
1 to 12	7'-0"	5 to 8	11'-2 3/4"
2 to 3	8'-10 1/2"	5 to 9	5'-0"
2 to 4	20'-9"	5 to 10	5'-0"
2 to 5	11'-0"	5 to 11	16'-1 3/4"
2 to 6	12'-0"	5 to 12	19'-1 3/4"
2 to 7	16'-10 1/2"	6 to 7	18'-10 1/4"
2 to 8	14'-1 1/2"	6 to 8	18'-6 1/2"
2 to 9	8'-5 1/2"	6 to 9	17'-5"
2 to 10	6'-0"	6 to 10	17'-0 1/2"
2 to 11	6'-0"	6 to 11	6'-0"
2 to 12	12'-0 1/4"	6 to 12	6'-0"
3 to 4	13'-0"	7 to 8	3'-11 1/4"
3 to 5	11'-0"	7 to 9	11'-2 1/4"
3 to 6	12'-11 1/2"	7 to 10	14'-10 1/4"
3 to 7	8'-0 3/4"	7 to 11	16'-11"
3 to 8	6'-0"	7 to 12	13'-1 1/4"
3 to 9	6'-0"	8 to 9	7'-5"
3 to 10	8'-4"	8 to 10	11'-2 3/4"
3 to 11	9'-4 3/4"	8 to 11	15'-4 3/4"
		8 to 12	13'-5"
		9 to 10	3'-10 3/4"
		9 to 11	12'-4 1/4"
		9 to 12	14'-3 1/2"
		10 to 11	11'-3 1/2"
		10 to 12	15'-3"
		11 to 12	7'-5"
		S1 to S2	12'-6 3/4"
		S1 to H1	8'-2"
		S1 to H2	17'-6 3/4"
		S2 to H1	13'-6 1/2"
		S2 to H2	8'-6 3/4"
		H1 to H2	14'-0"

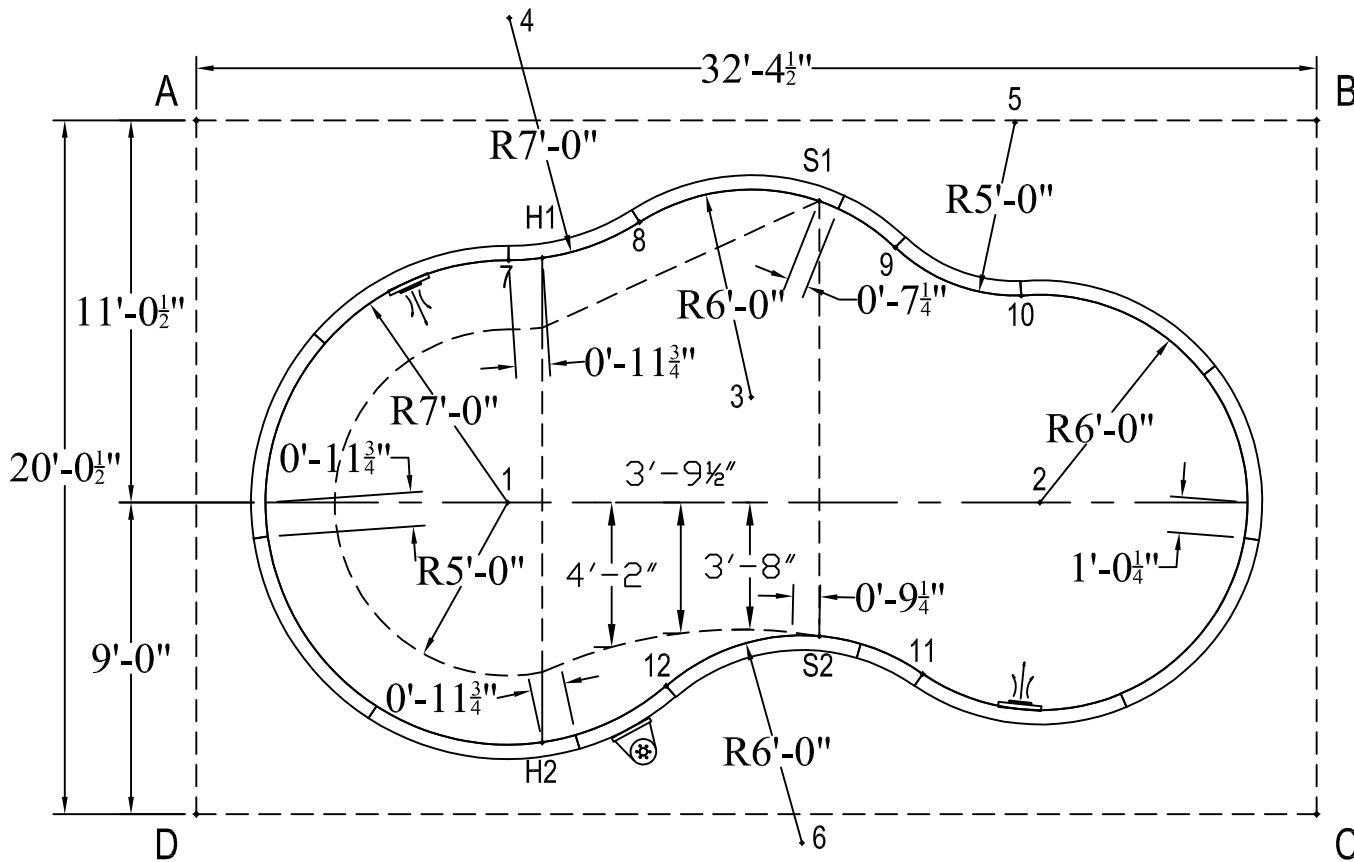

MOUNTAIN LAKE

14-0 X 16-1 X 28-5 LEFT

DATE:01/01/2019

ATLAS SERIES