

# STEP OPTIONS

## STEP OPTION 1

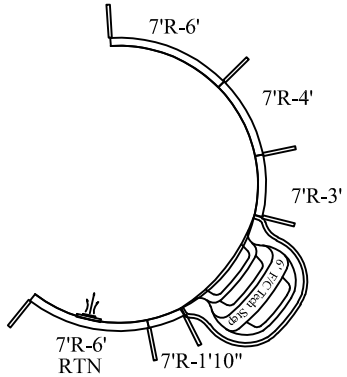

## STEP OPTION 2

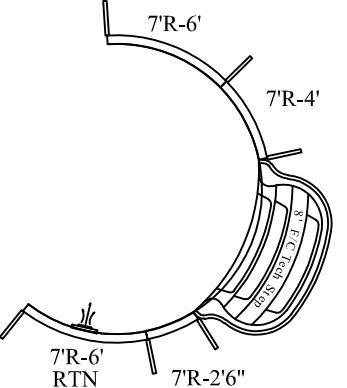

## STEP OPTION 3

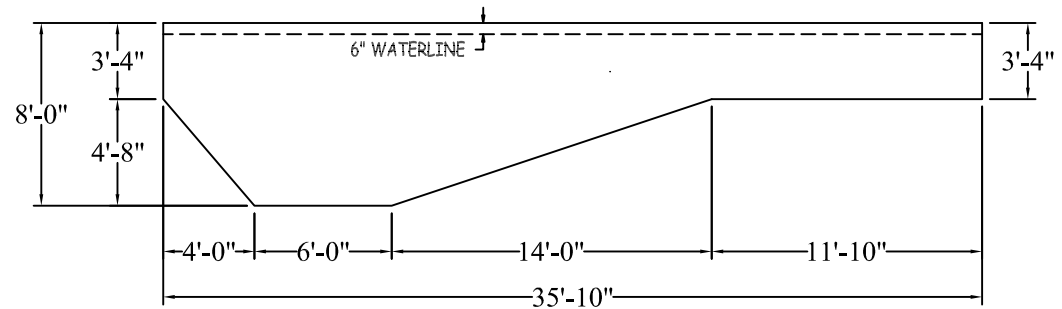
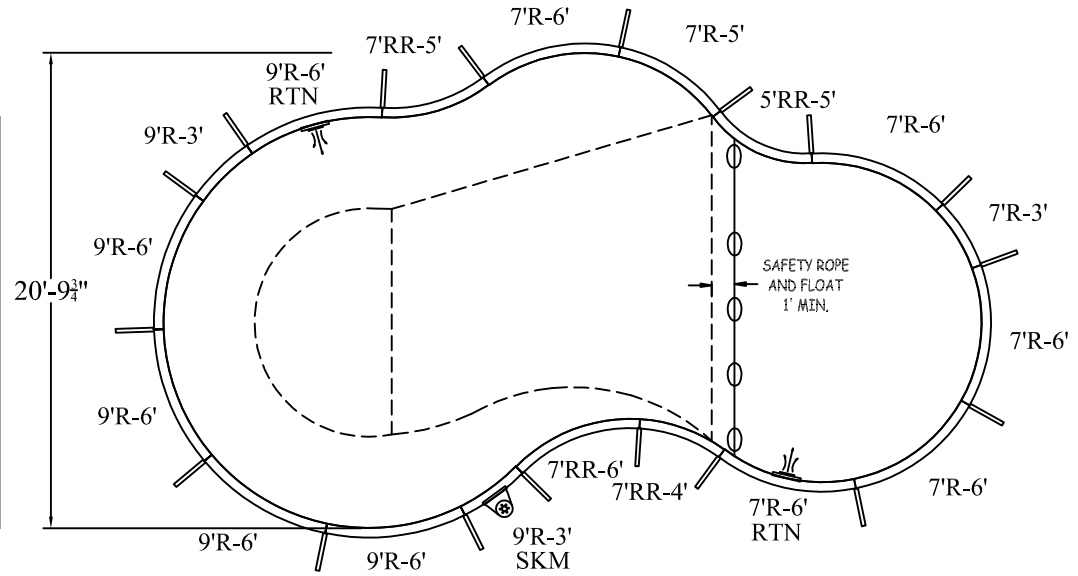
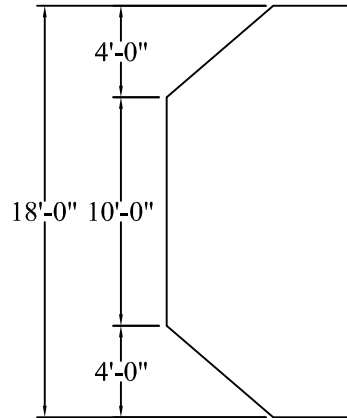
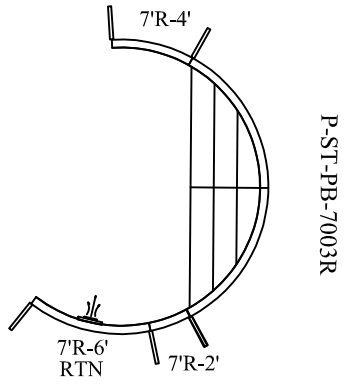

MOUNTAIN LAKE

DATE: 01/01/2019

PERIMETER: 94'-0" LIN.FT.

REVISION:

SURFACE (ft²): 521.9505

18-0 X 20-10 X 35-10 LEFT

SCALE: N.T.S.

LINER (ft²): 644.9994

APPROX. WATER VOLUME: 67 000 LITRES

COVER (ft²): 925.5070

FREEFORM

# ATLAS SERIES

### WARNING

SWIMMING POOLS ARE DANGEROUS WHEN USED IMPROPERLY. CONSULT YOUR DEALER FOR INFORMATION ON THE SAFE USE OF SWIMMING POOLS. IT IS THE RESPONSIBILITY OF TOWN OFFICIALS, BUILDERS AND HOME OWNERS TO FOLLOW ALL SAFETY RECOMMENDATIONS OF LOCAL ORDINANCES AND EQUIPMENT MANUFACTURERS FOR DIVING & SLIDING EQUIPMENT REFER TO THE MANUFACTURER'S INSTRUCTIONS TO CORRECTLY POSITION & INSTALL EQUIPMENT.

	A	B	C	D		A	B	C	D
1	17'-7 3/4"	31'-11 1/2"	30'-10 1/4"	15'-6 3/4"	S1	26'-5"	14'-7 1/2"	24'-4 1/2"	32'-10 1/4"
2	33'-9 1/2"	16'-5 3/4"	14'-2 1/2"	32'-8 3/4"	S2	32'-2 1/4"	23'-5 3/4"	15'-0"	26'-7 3/4"
3	22'-4 1/4"	21'-4 1/2"	25'-0"	25'-10 1/4"	H1	12'-11 1/4"	28'-3"	34'-3"	23'-3 1/2"
4	12'-2 1/2"	27'-11"	38'-9"	29'-6 1/4"	H2	25'-8 3/4"	35'-11 1/4"	27'-11"	12'-2"
5	30'-1 1/2"	9'-11 1/4"	24'-11 1/2"	37'-10 1/4"	A	-	39'-10"	46'-11"	24'-9 3/4"
6	33'-7"	30'-5 1/2"	17'-4 3/4"	22'-5 1/4"					
7	12'-6 1/4"	28'-8"	34'-7 1/2"	23'-1"					
8	16'-7 1/4"	23'-10"	31'-10 1/4"	26'-10 1/2"					
9	26'-6"	14'-7"	24'-3 1/2"	32'-10 1/4"					
10	31'-1 3/4"	11'-7 3/4"	20'-3 3/4"	35'-3 3/4"					
11	32'-10 1/2"	23'-5 1/2"	14'-4 1/4"	27'-1 1/2"					
12	26'-7 1/4"	30'-1 1/4"	22'-10 3/4"	18'-0 1/2"					

DIAGONALS		3 to 12	11'-6"
1 to 2	19'-10"	4 to 5	18'-6"
1 to 3	10'-7 1/4"	4 to 6	29'-1 1/4"
1 to 4	16'-0"	4 to 7	7'-0"
1 to 5	22'-6 1/4"	4 to 8	7'-0"
1 to 6	16'-0"	4 to 9	15'-8 1/4"
1 to 7	9'-0"	4 to 10	20'-5 1/2"
1 to 8	11'-7 3/4"	4 to 11	25'-11 3/4"
1 to 9	17'-6 1/2"	4 to 12	22'-11"
1 to 10	20'-7 1/4"	5 to 6	24'-4 3/4"
1 to 11	16'-6 1/4"	5 to 7	18'-9"
1 to 12	9'-0"	5 to 8	13'-11"
2 to 3	11'-5 1/4"	5 to 9	5'-0"
2 to 4	24'-8 1/4"	5 to 10	5'-0"
2 to 5	12'-0"	5 to 11	17'-10 1/2"
2 to 6	14'-0"	5 to 12	22'-2 3/4"
2 to 7	21'-3"	6 to 7	22'-11"
2 to 8	17'-11"	6 to 8	22'-5 1/2"
2 to 9	10'-2 1/4"	6 to 9	20'-6 1/4"
2 to 10	7'-0"	6 to 10	19'-10 1/4"
2 to 11	7'-0"	6 to 11	7'-0"
2 to 12	14'-9 3/4"	6 to 12	7'-0"
3 to 4	14'-0"	7 to 8	4'-10 3/4"
3 to 5	12'-0"	7 to 9	14'-5 3/4"
3 to 6	16'-1 1/2"	7 to 10	18'-11 1/4"
3 to 7	9'-9 3/4"	7 to 11	20'-10 1/2"
3 to 8	7'-0"	7 to 12	16'-4 1/2"
3 to 9	7'-0"	8 to 9	9'-11"
3 to 10	10'-2"	8 to 10	14'-6 1/2"
3 to 11	12'-0 1/4"	8 to 11	19'-0"
		8 to 12	16'-8 3/4"
		9 to 10	4'-9 1/2"
		9 to 11	14'-6 3/4"
		9 to 12	17'-6 3/4"
		10 to 11	13'-1 1/4"
		10 to 12	18'-6 3/4"
		11 to 12	9'-2"
		S1 to S2	14'-3"
		S1 to H1	14'-0"
		S1 to H2	22'-9 3/4"
		S2 to H1	19'-10 3/4"
		S2 to H2	14'-6"
		H1 to H2	17'-11"

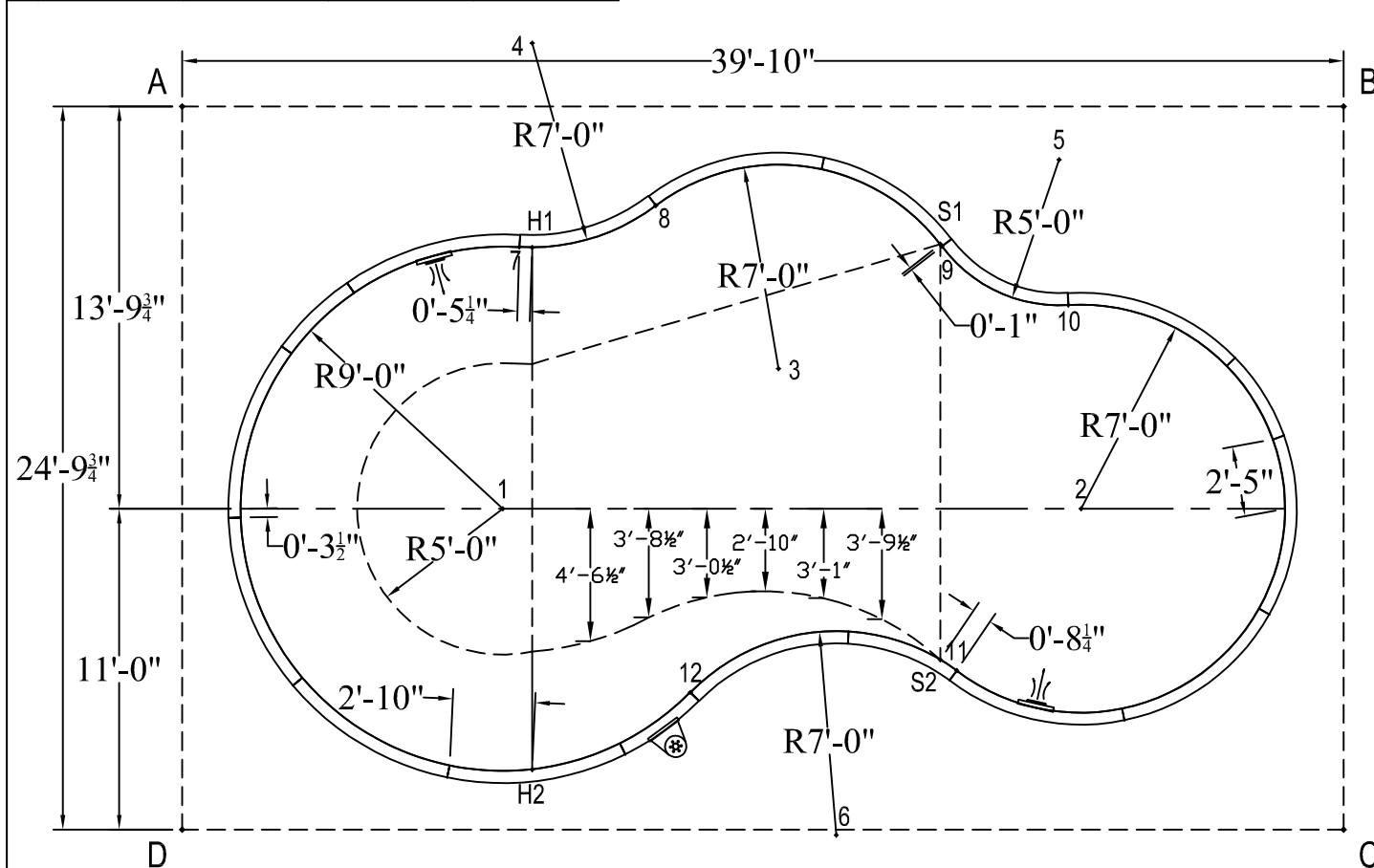

MOUNTAIN LAKE

18-0 X 20-10 X 35-10 LEFT

DATE:01/01/2019

ATLAS SERIES